

# HONDA

## SERVICE MANUAL

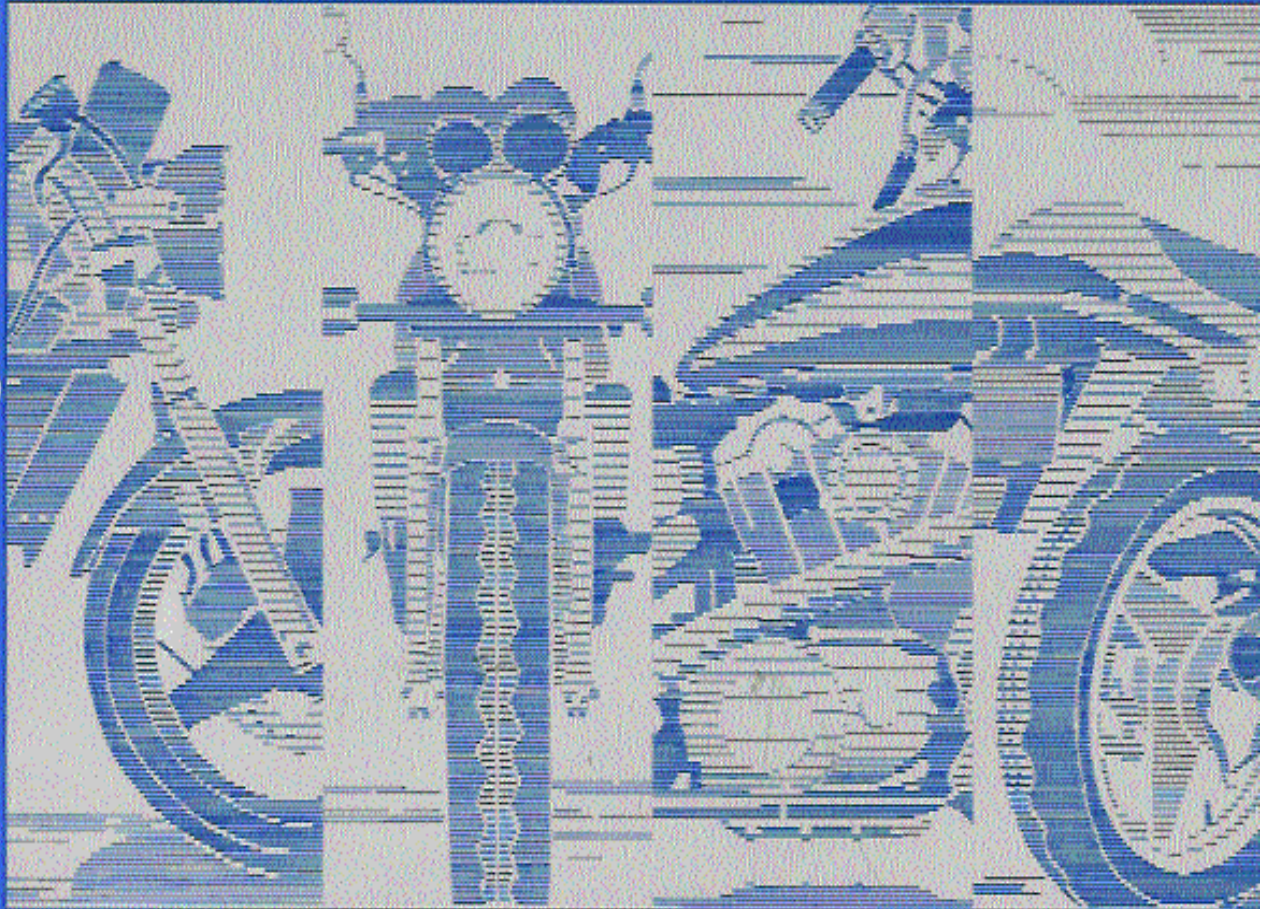

**89-90, 94-98**

**PC800**

**PACIFIC COAST™**

© HONDA MOTOR CO., LTD. 1994

## Important Safety Notice

**▲ WARNING** Indicates a strong possibility of severe personal injury or death if instructions are not followed.

**CAUTION:** Indicates a possibility of equipment damage if instructions are not followed.

**NOTE:** Gives helpful information.

Detailed descriptions of standard workshop procedures, safety principles and service operations are not included. It is important to note that this manual contains *some* warnings and cautions against some specific service methods which could cause **PERSONAL INJURY** to service personnel or could damage a vehicle or render it unsafe. Please understand that those warnings could not cover all conceivable ways in which service, whether or not recommended by Honda, might be done or of the possibly hazardous consequences of each conceivable way, nor could Honda investigate all such ways. Anyone using service procedures or tools, whether or not recommended by Honda, *must satisfy himself thoroughly* that neither personal safety nor vehicle safety will be jeopardized by the service methods or tools selected.

## Introduction

This service manual describes the service procedures for and technical features of the PC800.

This Model Specific Manual includes every service procedure that is of a specific nature to this particular model. Basic service procedures that are common to other Honda Motorcycles/Motor Scooters/ATVs are covered in the Common Service Manual. This Model Specific Service Manual should be used together with the Common Service Manual in order to provide complete service information on all aspects of this motorcycle.

Follow the Maintenance Schedule (Section 3) recommendations to ensure that the vehicle is in peak operating condition and that emission levels are within the standards set by the U.S. Environmental Protection Agency and the California Air Resources Board. Performing the first scheduled maintenance is very important. It compensates for the initial wear that occurs during the break-in period.

Section 1 and 3 apply to the whole motorcycle. Section 2 illustrates procedures for removal/installation of components that may be required to perform service described in the following sections.

Sections 4 through 19 describe parts of the motorcycle, grouped according to locations.

Find the section you want on this page, then turn to the table of contents on the first page of the section.

Most sections describe the service procedure through system illustration. Refer to the next page for details on how to use this manual.

If you are not familiar with this motorcycle, read Technical Feature in section 20.

If you don't know the source of the trouble, go to section 21, TROUBLESHOOTING.

ALL INFORMATION, ILLUSTRATIONS, DIRECTIONS AND SPECIFICATIONS INCLUDED IN THIS PUBLICATION ARE BASED ON THE LATEST PRODUCT INFORMATION AVAILABLE AT THE TIME OF APPROVAL FOR PRINTING. HONDA MOTOR CO., LTD. RESERVES THE RIGHT TO MAKE CHANGES AT ANY TIME WITHOUT NOTICE AND WITHOUT INCURRING ANY OBLIGATION WHATEVER. NO PART OF THIS PUBLICATION MAY BE REPRODUCED WITHOUT WRITTEN PERMISSION. THIS MANUAL IS WRITTEN FOR PERSONS WHO HAVE ACQUIRED BASIC KNOWLEDGE OF MAINTENANCE ON HONDA MOTORCYCLES, MOTOR SCOOTERS OR ATVS.

HONDA MOTOR CO.,LTD.  
SERVICE PUBLICATION OFFICE

## Contents

	General Information	1
	Frame/Body Panels/Exhaust System	2
	Maintenance	3
Engine and Drive Train	Lubrication System	4
	Fuel System	5
	Cooling System	6
	Engine Removal/Installation	7
	Cylinder Head/Cylinder/Piston	8
	Clutch/Gearshift Linkage	9
	Crankshaft/Transmission	10
	Final Drive	11
	Chassis	Front Wheel/Suspension/Steering
Rear Wheel/Suspension		13
Brake System		14
Electrical	Charging System/Alternator	15
	Ignition System	16
	Electric Starter/Starter Clutch	17
	Lights/Meters/Switches	18
	Wiring Diagram	19
	Technical Feature	20
	Troubleshooting	21
	Index	22



# How to Use This Manual

## Finding Information You Need

- This manual is divided into sections which cover each of the major components of the motorcycle. To quickly find the section you are interested in, the first page of each section is marked with a black tab that lines up with one of the thumb index tabs before this page. The first page of each section lists the table of contents within the section. Read the service information and troubleshooting related to the section before you begin working.
- An index of the entire book is provided in the last chapter to directly locate the information you need.

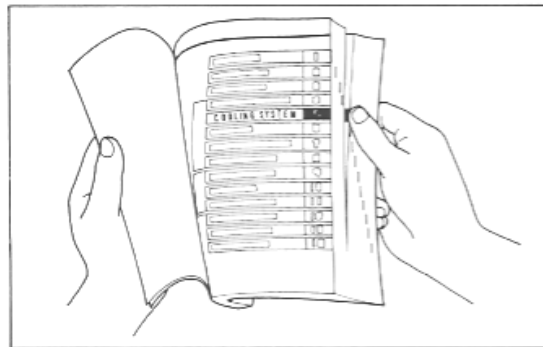

## Note on the Explanation Method of This Manual

- The removal and installation of parts are for the most part illustrated by large and clear illustrations that should provide the reader with visual aid in understanding the major point for servicing.
- The system illustrations are augmented by callouts whose numbers or letters indicate the order in which the parts should be removed or installed.
- The sequence of steps represented numerically are differentiated from the ones represented alphabetically to notify the reader that they must perform these steps separately. For example, if the steps prior and up to camshaft removal are performed with the engine installed, but the subsequent steps like cylinder head removal require engine removal, the callouts are grouped in numerical and alphabetical orders.
- The illustrations may contain symbol marks to indicate necessary service procedures and precautions that need to be taken. Refer to the next page for the meaning of each symbol mark.
- Also in the illustration is a chart that lists information such as the order in which the part is removed/installed, the name of the part, and some extra notes that may be needed.
- Step by step instructions are provided to supplement the illustrations when detailed explanation of the procedure is necessary or illustrations alone would not suffice.
- Service procedures required before or after the procedure described on that particular page, or inspection/adjustment procedures required following the installation of parts, are described under the title Requisite Service.
- Standard workshop procedures and knowledge covered in the Common Service Manual are abbreviated in this manual.

**Symbol mark**

**System illustration**

**Detailed description of the procedure**

**CYLINDER HEAD REMOVAL/INSTALLATION**

**REQUISITE SERVICE**

PROCEEDURE	QTY	REMARKS
1. HEADLAMP COVER	1	Installation is in the reverse order of removal. (Installation page 8-5)
2. Cylinder head mounting bolt	12	Install with the UP mark facing up and use wash.
3. Cylinder head mounting nut	12	Installation page 8-5
4. Shim	3	
5. Shim	3	
6. Camshaft oil gear cover bolt	2	
7. Camshaft oil gear cover shim	1	
8. Timing marker	1	
9. Camshaft oil gear case	1	
10. Carburetor mixture	4	At installation, align the breaker points with the timing key with the 0-10 mark facing towards the breaker side.

**TORQUE**

Head bolt: 30 N·m (2.2 kg-m, 22 ft·lb)  
Mounting bolt: 12 N·m (1.2 kg-m, 8 ft·lb)

**Step sequence (numerals or alphabets)**















**Part number**

**Number of parts**

**Extra notes or precaution related to the service procedure**

## Symbols

The symbols used throughout this manual show specific service procedures. If supplementary information is required pertaining to these symbols, it would be explained specifically in the text without the use of the symbols.

	Replace the part(s) with new one(s) before assembly.
	Use special tool
	Use optional tool. These tools are obtained as you order parts.
 10 (1.0, 7.2)	Torque specification. 10 N·m (1.0 kg·m, 7.2 ft·lb)
	Use recommended engine oil, unless otherwise specified.
	Use molybdenum oil solution (mixture of the engine oil and molybdenum grease with the ratio 1 : 1).
	Use multi-purpose grease (Lithium based multi-purpose grease NLGI #2 or equivalent)
	Use molybdenum disulfide grease (containing more than 3% molybdenum disulfide, NLGI #2 or equivalent) Example: Molykote® BR-2 plus manufactured by Dow Corning, U.S.A. Multi-purpose M-2 manufactured by Mitsubishi Oil Japan
	Use molybdenum disulfide paste (containing more than 40% molybdenum disulfide, NLGI #2 or equivalent) Example: Molykote® G-n Paste manufactured by Dow Corning, U.S.A. Honda Moly 45 (U.S.A. only) Rocol ASP manufactured by Rocol Limited, U.K. Rocol Paste manufactured by Sumico Lubricant, Japan
	Use silicone grease
	Apply a locking agent. Use the agent of the middle strength, unless otherwise specified.
	Apply sealant
	Use brake fluid, DOT 3 or DOT 4. Use the recommended brake fluid, unless otherwise specified.
	Use Fork or Suspension Fluid.

---

**MEMO**

# 1. General Information

1

General Safety	1-1	Lubrication & Seal Points	1-20
Model Identification	1-3	Cable & Harness Routing	1-22
Specifications	1-4	Emission Control Systems	1-28
Torque Values	1-14	Emission Control Information Labels (U.S.A. Only)	1-30
Tools	1-18		

## General Safety

### Carbon Monoxide

If the engine must be running to do some work, make sure the area is well ventilated. Never run the engine in an enclosed area.

#### ▲ WARNING

- The exhaust contains poisonous carbon monoxide gas that can cause loss of consciousness and may lead to death.

Run the engine in an open area or with an exhaust evacuation system in an enclosed area.

### Gasoline

Work in a well ventilated area. Keep cigarettes, flames or sparks away from the work area or where gasoline is stored.

#### ▲ WARNING

- Gasoline is extremely flammable and is explosive under certain conditions. KEEP OUT OF REACH OF CHILDREN.

### Hot Components

#### ▲ WARNING

- Engine and exhaust system parts become very hot and remain hot for some time after the engine is run. Wear insulated gloves or wait until the engine and exhaust system have cooled before handling these parts.

### Used Engine/Transmission Oil

#### ▲ WARNING

- Used engine oil (or transmission oil in two-strokes) may cause skin cancer if repeatedly left in contact with the skin for prolonged periods. Although this is unlikely unless you handle used oil on a daily basis, it is still advisable to thoroughly wash your hands with soap and water as soon as possible after handling used oil. KEEP OUT OF REACH OF CHILDREN.

### Brake Dust

Never use an air hose or dry brush to clean brake assemblies. Use an OSHA-approved vacuum cleaner or alternate method approved by OSHA, designed to minimize the hazard caused by airborne asbestos fibers.

#### ▲ WARNING

- Inhaled asbestos fibers have been found to cause respiratory disease and cancer.

### Brake Fluid

#### CAUTION

- Spilling fluid on painted, plastic or rubber parts will damage them. Place a clean shop towel over these parts whenever the system is serviced. KEEP OUT OF REACH OF CHILDREN.

## General Information

---

### Coolant

Under some conditions, the ethylene glycol in engine coolant is combustible and its flame is not visible. If the ethylene glycol does ignite, you will not see any flame, but you can be burned.

#### ⚠ WARNING

- Avoid spilling engine coolant on the exhaust system or engine parts. They may be hot enough to cause the coolant to ignite and burn without a visible flame.
- Coolant (ethylene glycol) can cause some skin irritation and is poisonous if swallowed. **KEEP OUT OF REACH OF CHILDREN.**
- Do not remove the radiator cap when the engine is hot. The coolant is under pressure and could scald you.
- Keep hands and clothing away from the cooling fan, as it starts automatically.

If it contacts your skin, wash the affected areas immediately with soap and water. If it contacts your eyes, flush them thoroughly with fresh water and get immediate medical attention. If it is swallowed, the victim must be forced to vomit then rinse mouth and throat with fresh water before obtaining medical attention. Because of these dangers, always store coolant in a safe place, away from the reach of children.

### Nitrogen Pressure

For shock absorbers with a gas-filled reservoir:

#### ⚠ WARNING

- Use only nitrogen to pressurize the shock absorber. The use of an unstable gas can cause a fire or explosion resulting in serious injury.
- The shock absorber contains nitrogen under high pressure. Allowing fire or heat near the shock absorber could lead to an explosion that could result in serious injury.
- Failure to release the pressure from a shock absorber before disposing of it may lead to a possible explosion and serious injury if it is heated or pierced.

To prevent the possibility of an explosion, release the nitrogen by pressing the valve core. Then remove the valve stem from the shock absorber reservoir. Dispose of the oil in a manner acceptable to the Environmental Protection Agency (EPA).

Before disposal of the shock absorber, release the nitrogen by pressing the valve core. Then remove the valve stem from the shock absorber.

### Battery Hydrogen Gas & Electrolyte

#### ⚠ WARNING

- The battery gives off explosive gases; keep sparks, flames and cigarettes away. Provide adequate ventilation when charging.
- The battery contains sulfuric acid (electrolyte). Contact with skin or eyes may cause severe burns. Wear protective clothing and a face shield.
  - If electrolyte gets on your skin, flush with water.
  - If electrolyte gets in your eyes, flush with water for at least 15 minutes and call a physician.
- Electrolyte is poisonous.
  - If swallowed, drink large quantities of water or milk and follow with milk of magnesia or vegetable oil and call a physician. **KEEP OUT OF REACH OF CHILDREN.**

## Model Identification

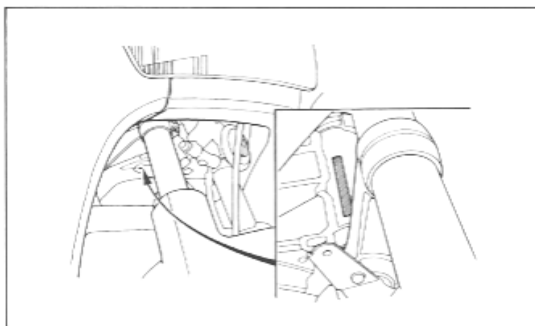
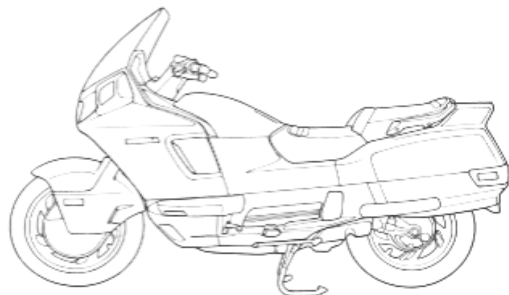

**(1) FRAME SERIAL NUMBER**

The frame serial number is stamped on the right side of the steering head.

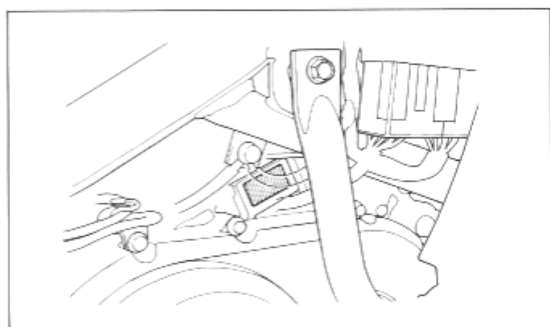

**(2) ENGINE SERIAL NUMBER**

The engine serial number is stamped on the right crankcase below the rear cylinder.

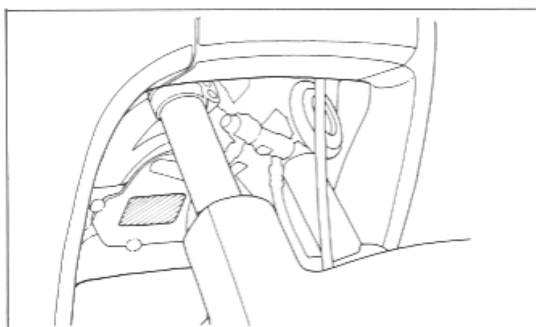

**(3) VEHICLE IDENTIFICATION NUMBER**

The Vehicle Identification Number (VIN) is located on the safety certification label attached to the frame, near the steering head.

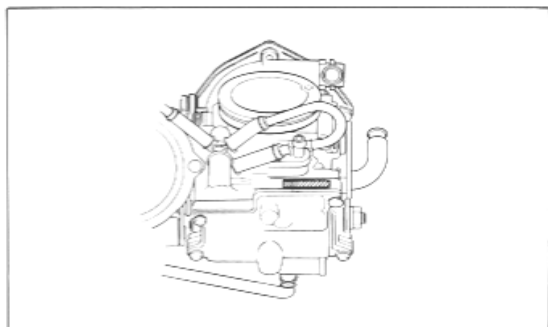

**(4) CARBURETOR IDENTIFICATION NUMBER**

The carburetor identification number is stamped on the carburetor body intake side.

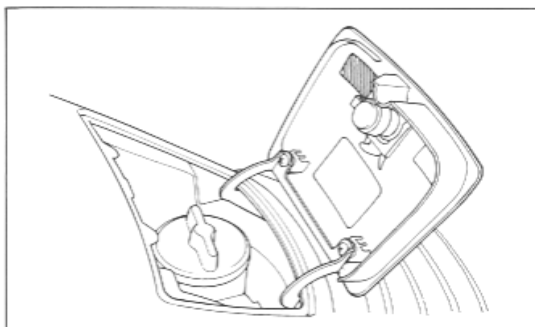

**(5) COLOR CODE LABEL**

The color label is attached inside the fuel filler compartment. When ordering color-coded part, always specify its designated color.

General Information

Specifications

Unit: mm (in)

General			
	Item	Specifications	
Dimensions	Overall length	2,290 (90.2)	
	Overall width	820 (32.3)	
	Overall height ('89-'90)	1,370 (53.9)	
	(After '90)	1,420 (55.9)	
	Wheel base	1,555 (61.2)	
	Seat height	765 (30.1)	
	Foot peg height	—	
	Ground clearance	140 (5.5)	
	Dry weight <California model>		
	('89-'90)	262 kg (578 lb) < 263 kg (580 lb)>	
(After '90)	265 kg (584 lb) < 266 kg (586 lb)>		
Curb weight <California model>			
	('89-'90)	280 kg (617 lb) < 281 kg (619 lb)>	
	(After '90)	283 kg (624 lb) < 284 kg (626 lb)>	
	Maximum weight capacity	167 kg (369 lb)	
	Frame	Frame type	Double cradle
		Front suspension	Telescopic fork
		Front wheel travel	145 (5.7)
		Rear suspension	Swingarm
		Rear wheel travel	130 (5.1)
		Rear damper	Double effect type
Cold tire pressure			
Up to 90 kg (200 lb) load (FR)		33 psi (225 kPa, 2.25 kg/cm <sup>2</sup> )	
Up to 90 kg (200 lb) load (RR)		33 psi (225 kPa, 2.25 kg/cm <sup>2</sup> )	
Up to maximum weight capacity (FR)		33 psi (225 kPa, 2.25 kg/cm <sup>2</sup> )	
Up to maximum weight capacity (RR)		41 psi (280 kPa, 2.80 kg/cm <sup>2</sup> )	
Front tire size		120/80-17 61H	
Rear tire size		140/80-15 MC 67H	
Tire brand (Bridgestone)		FR/RR	
Tire brand (Dunlop)		FR/RR	
Tire brand (Yokohama)		FR/RR	
Tire brand (IRC)		FR/RR	
Front brake		Hydraulic double disc	
Rear brake		Mechanical drum	
Caster angle		28°	
Trail length		101 (4.0)	
Fuel tank capacity		16 lit. (4.2 US gal, 3.5 Imp gal)	
Fuel tank reserve capacity	—		
Fork leg oil capacity			
'89-'90, '94:	(R)	375 cc (11.1 US oz, 10.7 Imp oz)	
(L)		375 cc (11.1 US oz, 10.7 Imp oz)	
After '94:	(R)	369 cc (12.5 US oz, 13.0 Imp oz)	
(L)		379 cc (12.8 US oz, 13.3 Imp oz)	
Engine	Bore and stroke	79.5 x 80.6 (3.12 x 3.17)	
	Displacement	800 cc (48.8 cu-in)	
	Compression ratio	9.0 : 1	
	Valve train	Silent, multi-link chain drive and OHC with rocker arm	
	Intake valve opens at 1 mm lift	5° BTDC	
	Intake valve close at 1 mm lift	35° ABDC	
	Exhaust valve opens at 1 mm lift	40° BBDC	
	Exhaust valve close at 1 mm lift	5° ATDC	
	Lubrication system	Forced pressure and wet sump	
	Oil pump type	Trochoid	
	Cooling system	Liquid cooled	
	Air filtration	Paper filter	
	Crankshaft type	Unit type, 2 main journals	
	Engine weight	80 kg (176 lb)	
Firing order	Front—225°—Rear—495°—Front		
Cylinder arrangement	2 cylinder 45° V		
Cylinder number	Front: # 2, Rear: # 1		

General Information

Unit: mm (in)

General (Cont'd)		
	Item	Specifications
Carburetor	Carburetor type Throttle bore	Constant Velocity dual carburetor 36 (1.4)
Drive Train	Clutch system Clutch operation system Transmission Primary reduction Secondary reduction Third reduction Final reduction Gear ratio 1st Gear ratio 2nd Gear ratio 3rd Gear ratio 4th Gear ratio 5th Gear ratio 6th Gear ratio reverse Gearshift pattern	Multi-plate, wet Hydraulic operating 5 speeds 1.810 (37/67T) 0.882 (34/30T) 1.058 (17/18T) 3.400 (10/34T) 2.600 (15/39T) 1.700 (20/34T) 1.250 (24/30T) 0.964 (28/27T) 0.800 (30/24T) — — Left foot operated return system 1-N-2-3-4-5
Electrical	Ignition system Starting system Charging system Regulator/rectifier type Lighting system AC regulator type	Digitalized full transistor ignition Electric starter motor Triple phase output alternator SCR Shorted/triple phase full-wave rectification Battery —

**General Information**

Unit: mm (in)

Lubrication	Item	Standard	Service Limit
	Engine oil capacity at draining at disassembly at oil filter change Recommended engine oil	3.0 lit. (3.20 US qt, 2.60 Imp qt) 3.5 lit. (3.70 US qt, 3.10 Imp qt) 3.2 lit. (3.41 US qt, 2.82 Imp qt) Use Honda 4-stroke Oil or equivalent API Service Classification: SF or SG Viscosity: SAE 10W-40	— — —
	<div style="text-align: center;"> <p><b>OIL VISCOSITIES</b></p> </div>	Other viscosity shown in the chart may be used when the average temperature in your riding area is within the indicated range.	
	Oil pressure at oil pressure switch	441 kPa (4.5 kg/cm <sup>2</sup> , 64 psi) at 6,000 rpm (80°C/176°F)	—
	Oil pump rotor tip clearance body clearance end clearance	0.15 (0.006) 0.15-0.22 (0.006-0.009) 0.02-0.07 (0.001-0.003)	0.20 (0.008) 0.35 (0.014) 0.10 (0.004)
	Final drive gear oil capacity at disassembly at draining	180 cc (6.1 US oz, 5.5 Imp oz) 150 cc (5.1 US oz, 4.6 Imp oz)	

Fuel System			
Carburetor identification number		VDGTA	—
	(California model)	VDGUA	—
Main jet		—	—
	(High altitude)	—	—
	(2, 3)	—	—
	(1, 4)	—	—
	(Front)	# 125	—
	(Rear)	# 122	—
Slow jet		# 38	—
Jet needle clip position		—	—
Pilot screw initial opening		1-1/8 turns out	—
	(California model)	1-1/8 turns out	—
Pilot screw high altitude adjustment		1/2 turns in	—
Pilot screw final opening		1/4 turns out	—
Air screw initial opening		—	—
	(California model)	—	—
Air screw high altitude adjustment		—	—
Float level		7.5 (0.30)	—
Carburetor vacuum difference		20 mmHg (0.8 inHg)	40 mmHg (1.6 inHg)
Base carburetor (For carburetor synchronization)		Rear cylinder carburetor	—
Idle speed		1,200 ± 100 rpm	—
Throttle grip free play		2-6 (0.08-0.24)	—
Accelerator pump clearance		—	—
Pulse air injection system		—	—
Pulse secondary air injection control valve vacuum pressure		—	—

General Information

Unit: mm (in)

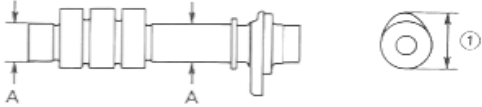
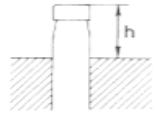
Cylinder Head	Item	Standard	Service Limit
	Cylinder compression	1,280–1,320 kPa (12.8–13.2 kg/cm <sup>2</sup> , 182–188 psi)/400 rpm	—
	Cylinder compression difference	40 mmHg (1.6 inHg)	—
	Valve clearance IN	—	—
	EX	—	—
	Cylinder head warpage	—	0.10 (0.004)
	Cam lobe height ① IN	38.101 (1.5000)	38.07 (1.499)
	IN (California model)	—	—
	EX	37.869 (1.4909)	37.84 (1.490)
	EX (California model)	—	—
	Camshaft runout	—	0.05 (0.002)
	Camshaft oil clearance A	0.050–0.111 (0.0020–0.0044)	0.13 (0.005)
	B	—	—
			
	Camshaft journal O.D. A	23.949–23.970 (0.9429–0.9437)	23.92 (0.941)
	B	—	—
	Camshaft holder I.D. A	24.000–24.021 (0.9449–0.9457)	24.07 (0.948)
	B	—	—
	Valve stem O.D. IN	6.575–6.590 (0.2589–0.2594)	6.57 (0.259)
	EX	6.550–6.570 (0.2579–0.2626)	6.54 (0.257)
	Valve guide I.D. IN	6.600–6.615 (0.2598–0.2604)	6.64 (0.261)
	EX	6.600–6.615 (0.2598–0.2604)	6.66 (0.262)
	Stem-to-guide clearance IN	0.010–0.040 (0.0004–0.0016)	0.08 (0.003)
	EX	0.030–0.065 (0.0012–0.0026)	0.12 (0.005)
	Valve guide projection above cylinder head IN (h)	14.5 ± 0.1 (0.57 ± 0.004)	—
	EX (h)	15.5 ± 0.1 (0.61 ± 0.004)	—
	 Before guide installation: 1. Chill the valve guides in the freezer section of a refrigerator for about an hour. 2. Heat the cylinder head to 100–150°C (212–300°F).		
	Valve seat width IN	0.9–1.1 (0.035–0.043)	1.5 (0.06)
	EX	1.2–1.4 (0.047–0.055)	1.8 (0.07)
	Valve spring free length IN	—	—
	EX	—	—
	inner IN	41.4 (1.63)	39.9 (1.57)
	inner EX	41.4 (1.63)	39.9 (1.57)
	outer IN	45.7 (1.80)	43.9 (1.73)
	outer EX	43.5 (1.71)	41.8 (1.65)
	Rocker arm I.D. IN	13.750–13.768 (0.5413–0.5420)	13.78 (0.543)
	EX	13.750–13.768 (0.5413–0.5420)	13.78 (0.543)
	Rocker arm shaft O.D. IN	13.716–13.734 (0.5400–0.5407)	13.71 (0.540)
	EX	13.716–13.734 (0.5400–0.5407)	13.71 (0.540)
	Rocker arm-to-rocker arm shaft clearance	0.016–0.052 (0.0006–0.0020)	0.072 (0.0028)
	Valve lifter O.D.	—	—
	Valve lifter bore I.D.	—	—
	Hydraulic tappet adjuster assist spring free length	18.57 (0.731)	17.80 (0.701)
	Hydraulic tappet adjuster compression stroke with kerosene	—	0.20 (0.008)

## General Information

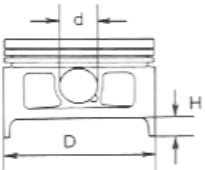
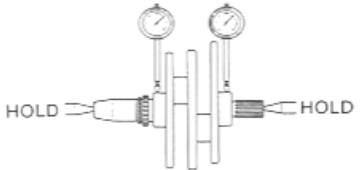
		Unit: mm (in)	
Cylinder/Piston	Item	Standard	Service Limit
	Cylinder I.D.	79.500—79.515 (3.1299—3.1305)	79.55 (3.132)
	Cylinder out of round	—	0.05 (0.002)
	Cylinder taper	—	0.05 (0.002)
	Cylinder warpage	—	0.05 (0.002)
	Piston mark direction	"IN" mark facing toward the intake side	—
	Piston O.D. (D)	79.470—79.490 (3.1287—3.1295)	79.41 (3.126)
	Piston O.D. measurement point (H)	13 (0.5) from the bottom	—
	Piston pin hole I.D. (d)	20.002—20.008 (0.7874—0.7877)	20.02 (0.788)
			
	Cylinder-to-piston clearance	0.010—0.045 (0.0004—0.0018)	0.32 (0.013)
	Piston pin O.D.	19.994—20.000 (0.7871—0.7874)	19.98 (0.787)
	Piston-to-piston pin clearance	0.002—0.014 (0.0001—0.0006)	0.03 (0.001)
	Connecting rod-to-piston pin clearance	0.020—0.047 (0.0008—0.0019)	0.07 (0.003)
	Top ring-to-ring groove clearance	0.015—0.045 (0.0006—0.0018)	0.25 (0.010)
	Second ring-to-ring groove clearance	0.015—0.045 (0.0006—0.0018)	0.25 (0.010)
	Top ring end gap	0.35—0.50 (0.014—0.020)	0.65 (0.026)
	Second ring end gap	0.35—0.50 (0.014—0.020)	0.65 (0.026)
	Top ring mark	"R" mark facing up	—
	Second ring mark	"R" mark facing up	—
<b>Crankshaft</b>			
	Connecting rod small end I.D.	20.016—20.034 (0.7880—0.7887)	20.05 (0.789)
	Connecting rod big end side clearance radial clearance	0.10—0.25 (0.0039—0.010)	0.40 (0.016)
	Crankshaft runout	—	0.05 (0.002)
			
	Crankpin oil clearance	0.028—0.052 (0.0011—0.0020)	0.07 (0.0028)
	Crankpin bearing selection	See page 10-8	—
	Main journal oil clearance	0.025—0.041 (0.0010—0.0016)	0.06 (0.0024)
	Main journal bearing selection	See page 10-6	—
<b>Kickstarter</b>			
	Kickstarter pinion gear I.D.	—	—
	Kickstarter spindle O.D.	—	—
	Kickstarter idle gear I.D.	—	—
	Countershaft O.D. at kickstarter idle gear	—	—
	Kickstarter idle gear bushing O.D. I.D.	—	—

General Information

Unit: mm (in)

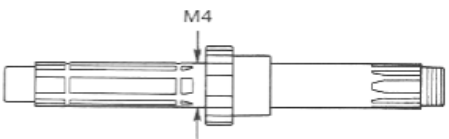
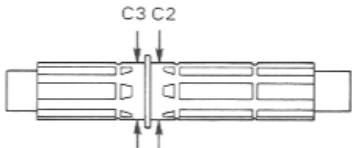
Transmission	Item	Standard	Service Limit
	Transmission gear I.D. C1, C2, C3	31.000–31.025 (1.2205–1.2215)	31.04 (1.222)
	M4, M5	28.000–28.021 (1.1024–1.1032)	27.98 (1.102)
	Transmission gear bushing O.D. C1, C2, C3	30.950–30.975 (1.2185–1.2195)	30.94 (1.218)
	M4, M5	27.959–27.980 (1.1007–1.1016)	27.94 (1.100)
	Transmission gear bushing I.D. C2, C3	27.995–28.016 (1.1022–1.1030)	28.03 (1.104)
	M4	25.000–25.021 (0.9843–0.9851)	25.04 (0.986)
	Gear-to-bushing clearance at C1, C2, C4 gear	0.025–0.075 (0.0010–0.0030)	0.095 (0.0037)
	at M4, M5 gear	0.020–0.062 (0.0008–0.0024)	0.072 (0.0028)
	Mainshaft O.D. at M4 gear	24.982–24.995 (0.9835–0.9841)	24.96 (0.983)
			
	Countershaft O.D. at C2, C3 gear	27.977–27.990 (1.1015–1.1020)	27.97 (1.101)
			
	Gear-to-shaft clearance	—	—
	Gear bushing-to-shaft clearance at C2, C3 gear	0.005–0.039 (0.0002–0.0015)	0.059 (0.0023)
	at M4 gear	0.005–0.039 (0.0002–0.0015)	0.059 (0.0023)
	Shift fork claw thickness L	6.493–6.500 (0.2556–0.2559)	6.40 (0.252)
	C	6.493–6.500 (0.2556–0.2559)	6.40 (0.252)
	R	6.493–6.500 (0.2556–0.2559)	6.40 (0.252)
	Shift fork I.D. L	14.000–14.021 (0.5512–0.5520)	14.04 (0.553)
	C	14.000–14.021 (0.5512–0.5520)	14.04 (0.553)
	R	14.000–14.021 (0.5512–0.5520)	14.04 (0.553)
	Shift fork shaft O.D. L	13.966–13.984 (0.5498–0.5506)	13.90 (0.547)
	C	13.966–13.984 (0.5498–0.5506)	13.90 (0.547)
	R	13.966–13.984 (0.5498–0.5506)	13.90 (0.547)

## General Information

Unit: mm (in)

Clutch System	Item	Standard	Service Limit
	Clutch lever free play	—	—
	Recommended clutch fluid	DOT 4 brake fluid	—
	Clutch master cylinder I.D.	14.000–14.043 (0.5512–0.5524)	14.06 (0.554)
	Clutch master piston O.D.	13.957–13.984 (0.5495–0.5506)	13.94 (0.549)
	Clutch outer I.D.	—	—
	Clutch outer guide O.D.	—	—
	I.D.	24.955–25.012 (0.9825–0.9847)	25.08 (0.987)
	Mainshaft O.D. at clutch outer guide	24.980–24.993 (0.9835–0.9840)	24.93 (0.981)
	Clutch spring free height	—	—
	Clutch spring free length	38.0 (1.50)	36.5 (1.44)
	Clutch disc thickness	—	—
	Clutch disc thickness A	3.792–3.808 (0.1493–0.1528)	3.30 (0.012)
	B	3.792–3.808 (0.1493–0.1528)	3.30 (0.012)
	Clutch plate warpage	—	0.30 (0.012)
	Centrifugal clutch drum I.D.	—	—
	bushing O.D.	—	—
	Centrifugal clutch center guide I.D.	—	—
	O.D.	—	—
	Centrifugal clutch center guide collar height	—	—
	Centrifugal clutch weight lining thickness	—	—
	Centrifugal clutch spring free length	—	—
	Clutch lining thickness	—	—
	Crankshaft O.D. at clutch center	—	—

Cooling System	Item	Standard	Service Limit
	Coolant capacity (Radiator and engine)	2.5 lit. (2.7 US qt, 2.2 Imp qt)	—
	(Reserve tank)	0.5 lit. (0.5 US qt, 0.4 Imp qt)	—
	Radiator cap relief pressure	93–123 kPa (0.95–1.25 kg/cm <sup>2</sup> , 14–18 psi)	—
	Thermostat begins to open	80–84°C (176–183°F)	—
	Thermostat fully open	95°C (203°F)	—
	Thermostat valve lift	9.0 (0.35) min.	—

Drive Train	Item	Standard	Service Limit
	Recommended final drive oil	Hypoid gear oil SAE #80	—
	Final drive gear oil capacity at disassembly	180 cc (6.1 US oz, 5.5 Imp oz)	—
	at draining	150 cc (5.1 US oz, 4.6 Imp oz)	—
	Final drive gear backlash	0.08–0.18 (0.003–0.007)	0.30 (0.012)
	Final drive gear backlash difference between measurements	—	0.10 (0.004)
	Ring gear-to-stop pin clearance (A)	0.30–0.60 (0.012–0.024)	—
	Stop pin shim	See page 11-11	—
	Ring gear spacer	See page 11-12	—
	Pinion spacer	See page 11-12	—
	Final drive gear assembly preload	0.2–0.4 N·m (2–4 kg·m, 1.7–3.5 ft·lb)	—
	Output gear backlash	0.08–0.024 (0.0031–0.0091)	0.40 (0.0157)
	Output gear I.D.	24.000–24.021 (0.9449–0.9457)	24.10 (0.9488)
	Output gear bushing O.D.	23.959–23.980 (0.9433–0.9411)	23.70 (0.9331)
	I.D.	20.020–20.041 (0.7882–0.7890)	20.10 (0.7913)
	Output drive shaft O.D.	19.979–20.000 (0.7866–0.7874)	19.97 (0.786)
	Output gear damper spring free length	61.0 (2.40)	59.8 (2.35)
	Output shaft adjustment shim	See page 10-25	—
	Countershaft drive shaft adjustment shim	See page 10-17	—

Unit: mm (in)

Wheels/Tires	Item	Standard	Service Limit
	Minimum tire tread depth (FR)	—	1.5 (0.06)
	(RR)	—	2.0 (0.08)
	Cold tire pressure Up to 90 kg (200 lb) load (FR)	33 psi (225 kPa, 2.25 kg/cm <sup>2</sup> )	—
	Up to 90 kg (200 lb) load (RR)	33 psi (225 kPa, 2.25 kg/cm <sup>2</sup> )	—
	Up to maximum weight capacity (FR)	33 psi (225 kPa, 2.25 kg/cm <sup>2</sup> )	—
	Up to maximum weight capacity (RR)	41 psi (280 kPa, 2.80 kg/cm <sup>2</sup> )	—
	Front and rear axle runout	—	0.20 (0.008)
	Front and rear wheel rim runout (Radial)	—	2.0 (0.08)
	(Axial)	—	2.0 (0.08)
	Front wheel hub-to-rim distance	—	—
	Front wheel hub standard surface	—	—
	Rear wheel hub-to-rim distance	—	—
	Rear wheel hub standard surface	—	—
	Wheel balance weight (Front)	—	Max. 60 g (2.1 oz)
	(Rear)	—	Max. 70 g (2.5 oz)
	Drive chain slack	—	—
	Drive chain size/link (DID)	—	—
	(RK)	—	—

Front Suspension	Item	Standard	Service Limit
	Fork spring free length	462.7 (18.22)	453.4 (17.85)
	Fork spring free length A	—	—
	B	—	—
	Fork spring direction	Taper wound coil facing down	—
	Fork tube runout	—	0.20 (0.008)
	Recommended fork oil	Fork fluid	—
	Fork oil level	163 (6.4)	—
	Fork oil level (R)	—	—
	(L)	—	—
	Fork oil capacity	—	—
	Fork oil capacity '89–'90, '94 (R)	375 cc (11.1 US oz, 10.7 Imp oz)	—
	(L)	375 cc (11.1 US oz, 10.7 Imp oz)	—
	After '94 (R)	369 cc (12.5 US oz, 13.0 Imp oz)	—
	(L)	379 cc (12.8 US oz, 13.3 Imp oz)	—
	Fork air pressure	—	—
	Steering bearing preload	1.1–1.6 kg	—

Rear Suspension	Item	Standard	Service Limit
	Shock absorber spring free length	—	—
	Shock absorber spring free length (R)	323.7 (12.74)	317.2 (12.49)
	(L)	294.5 (11.59)	288.6 (11.36)
	Damper gas pressure	—	—
	Damper compressed gas	—	—
	Damper rod compressed force at 10 mm compressed	—	—
	Damper drilling point	—	—
	Shock absorber spring installed length (Standard)	—	—
	(Adjustable range)	—	—
	Shock absorber spring adjuster standard position	2nd groove (Left)	—
	Shock absorber spring direction	Tightly wound coil facing upward (Right)	—
	Recommended shock absorber oil	—	—
	Shock absorber oil capacity	—	—
	air pressure	—	—

**General Information**

Unit: mm (in)

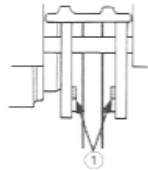
Brakes		Standard	Service Limit
Front brake fluid		DOT 4	—
brake lever free play		—	—
brake pad wear indicator		—	to the groove ①
			
brake disc thickness		5 (0.20)	4 (0.16)
brake disc runout		—	0.30 (0.012)
master cylinder I.D.		15.870—15.913 (0.6248—0.6265)	15.93 (0.627)
master piston O.D.		15.827—15.854 (0.6231—0.6242)	15.82 (0.623)
caliper cylinder I.D.		27.000—27.050 (1.0630—1.0650)	27.06 (1.065)
caliper cylinder I.D. (Upper)		—	—
(Lower)		—	—
caliper piston O.D.		26.918—26.968 (1.0598—1.0617)	26.91 (1.059)
caliper piston O.D. (Upper)		—	—
(Lower)		—	—
brake drum I.D.		—	—
brake lining thickness		—	—
Rear brake fluid		—	—
brake pedal height		—	—
brake pedal free play		20—30 (0.8—1.2)	—
brake pad wear indicator		—	—
brake disc thickness		—	—
runout		—	—
master cylinder I.D.		—	—
master piston O.D.		—	—
caliper cylinder I.D.		—	—
caliper piston O.D.		—	—
brake drum I.D.		180 (7.09)	181 (7.13)
brake lining thickness		5.0 (0.20)	2.0 (0.08)

Battery/Charging System		Standard	Service Limit
Alternator charging coil resistance (At 20°C/68°F)		0.1—1.0 Ω	—
Regulator/rectifier regulated voltage/amperage		13.5—15.5 V/5,000 rpm	—
Battery capacity		12 V—10 AH (Maintenance Free battery: YTX-12)	—
Specified Current leakage		—	Max, 10 μA
Battery specific gravity (Fully charging)		—	—
(Needs charging)		—	—
Battery charging rate (Nomal)		1.2 A x 5—10 h	—
(Quick)		5 A x 1 h	—
Battery voltage (Fully charged at 20°C/68°F)		13—13.2 V	—
(Needs charging at 20°C/68°F)		Below 12.3 V	—
Alternator lighting coil resistance (At 20°C/68°F)		—	—
AC regulator regulated voltage (With analogue type)		—	—
(With digital type)		—	—

General Information

Ignition System		Standard	Service Limit
Item			
Spark plug (Standard NGK)		DPR7EA-9	—
(Standard NIPPONDENSO)		X22EPR-U9	—
(For cold climate/below 5°C/41°F NGK)		DPR6EA-9	—
(For cold climate/below 5°C/41°F NIPPONDENSO)		X20EPR-U9	—
(For extended high speed riding NGK)		DPR8EA-9	—
(For extended high speed riding NIPPONDENSO)		X24EPR-U9	—
Spark plug gap		0.8–0.9 (0.031–0.035)	—
Ignition timing "F" mark		8.5°/1,200 rpm	—
Advance start		10°/1,800 rpm	—
stop		27.5°/7,000 rpm	—
Full advance		27.5°/7,000 rpm	—
Alternator exciter coil resistance (At 20°C/68°F)		—	—
Ignition coil resistance (Primary: at 20°C/68°F)		2.0–3.0 Ω	—
(Secondary with plug cap)		28–38 kΩ	—
(Secondary without plug cap)		20–25 kΩ	—
Ignition pulse generator resistance (At 20°C/68°F)		400–500 Ω	—

Lights/Meters/Switches		Standard	Service Limit
Main fuse		30 A	—
Fuse	('89)	10 A x 4, 15 A x 1	—
	(AFTER '89)	10 A x 3, 15 A x 1	—
Headlight (high/low beam)		12 V 60/55 W (H4)	—
Tail/brake light		12 V–2/32 cp	—
License light		12 V–3 cp	—
Position light bulb		—	—
Front turn signal/running light		12 V–32/3 cp	—
Front turn signal light		—	—
Rear turn signal light		12 V–32 cp	—
Instrument lights		12 V–3.4 W x 4	—
Oil pressure warning indicator		12 V–3.4 W	—
Tail/brake light warning indicator		—	—
Side stand warning indicator		12 V–3.4 W	—
Low fuel indicator		—	—
Coolant temperature indicator		—	—
Oil temperature indicator		—	—
High beam indicator		12 V–3.4 W	—
Turn signal indicator		12 V–3.4 W x 2	—
Neutral indicator		12 V–3.4 W	—
Reverse indicator		—	—
Overdrive indicator		—	—
Oil temperature sensor resistance		—	—
Fuel unit resistance (At full level)		4–10 Ω	—
(At empty)		90–100 Ω	—
Fuel pump minimum flow capacity (volume/minute)		600 cc	—
		(20.3 US oz, 21.1 Imp oz) min./at 10 V	—
Thermo sensor resistance	(50°C/122°F)	130–180 Ω	—
	(100°C/212°F)	25–30 Ω	—

Starting System		Standard	Service Limit
Starter driven gear O.D.		57.710–57.840 (2.2720–2.2772)	57.60 (2.268)
Starter clutch outer I.D.		74.414–74.440 (2.9297–2.9307)	74.50 (2.933)
Starter motor brush length		12.0–13.0 (0.47–0.51)	6.5 (0.26)

## General Information

### Torque Values

Standard		Torque			
Fasteners Type	Torque		Fasteners Type	Torque	
	N·m (kg-m, ft-lb)			N·m (kg-m, ft-lb)	
5 mm hex bolt and nut	5 (0.5, 3.5)		5 mm screw	4 (0.4, 3)	
6 mm hex bolt and nut	10 (1.0, 7.2)		6 mm screw	9 (0.9, 7)	
8 mm hex bolt and nut	22 (2.2, 16)		6 mm flange bolt (8 mm head)	9 (0.9, 7)	
10 mm hex bolt and nut	35 (3.5, 25)		6 mm flange bolt (10 mm head) and nut	12 (1.2, 9)	
12 mm hex bolt and nut	55 (5.5, 40)		8 mm flange bolt and nut	27 (2.7, 20)	
			10 mm flange bolt and nut	40 (4.0, 29)	

- Torque specifications listed below are for important fasteners.
- Others should be tightened to standard torque values listed above.

- Notes:
1. Apply sealant to the threads.
  2. Apply a locking agent to the threads.
  3. Apply molybdenum disulfide oil to the threads and flange surface.
  4. Left hand threads.
  5. Stake.
  6. Apply oil to the threads and flange surface.
  7. Apply clean engine oil to the O-ring.
  8. Torque wrench scale reading using a special tool.
  9. Apply grease to the threads and flange surface.
  10. UBS bolt.

Engine				
Item	Q'ty	Thread dia. (mm)	Torque N·m (kg-m, ft-lb)	Remarks
<b>Lubrication:</b>				
Oil filter cartridge	1	20	10 (1.0, 7.2)	NOTE 7
Oil drain bolt	1	14	35 (3.5, 25)	
Oil pump driven sprocket bolt	1	6	18 (1.8, 13)	NOTE 2
Oil orifice bolt	1	6	10 (1.0, 7.2)	
Oil pass pipe bolt	2	7	12 (1.2, 9)	
Oil control bolt	1	10	23 (2.3, 17)	
Oil pressure switch	1	PT1/8 in	12 (1.2, 9)	NOTE 1
<b>Fuel system:</b>				
Carburetor insulator band screw	4	5	2 (0.2, 1.45)	
<b>Cylinder head/cylinder/piston:</b>				
Assist shaft cap	6	14	22 (2.2, 16)	
Rocker arm shaft hole plug	6	20	40 (4.0, 29)	
Cylinder head cover bolt	8	10	43 (4.3, 31)	
bolt and cap nut	14	8	27 (2.7, 20)	
Cam sprocket bolt	4	7	18 (1.8, 13)	NOTE 2, 10
Spark plug	4	12	14 (1.4, 10)	
Spark plug sleeve	2	30	13 (1.3, 9)	NOTE 3
<b>Clutch/gearshift linkage:</b>				
Timing hole cap	1	45	18 (1.8, 13)	NOTE 3
Right crankcase cover bolt	14	6	12 (1.2, 9)	
Clutch center lock nut	1	22	110 (11.0, 79)	NOTE 5
Primary drive gear bolt	1	12	100 (10.0, 72)	NOTE 6, 10
Shift drum bearing set plate bolt	1	6	12 (1.2, 9)	NOTE 2
Shift drum stopper arm pivot bolt	1	6	10 (1.0, 7.2)	NOTE 2



## General Information

Item	Q'ty	Thread dia. (mm)	Torque N·m (kg·m, ft·lb)	Remarks
<b>Frame (Cont'd)</b>				
<b>Frame/body panels:</b>				
Main stand mounting bolt	2	10	55 (5.5, 40)	
Side stand pivot bolt	1	10	10 (1.0, 7.2)	
lock nut	1	10	30 (3.0, 22)	
Side stand switch mounting bolt	1	6	10 (1.0, 7.2)	NOTE 2
<b>Exhaust system:</b>				
Exhaust pipe joint nut ('89)	4	8	22 (2.2, 16)	
(AFTER '89)	4	8	18 (1.8, 13)	
Muffler band bolt	6	8	22 (2.2, 16)	
Muffler mounting stay bolt	2	8	27 (2.7, 20)	
Muffler cover bolt	3	6	12 (1.2, 9)	
<b>Cooling system:</b>				
Radiator mounting bolt (upper)	1	6	10 (1.0, 7.2)	
(lower)	2	6	10 (1.0, 7.2)	
Radiator cover mounting screw	2	4	1.8 (0.18, 1.3)	
Radiator reserve tank mounting bolt	1	6	10 (1.0, 7.2)	
Thermostat mounting bolt	1	6	12 (1.2, 9)	
Thermostat housing cover bolt	2	6	9 (0.9, 7)	
Radiator fan motor switch	1	16	18 (1.8, 13)	NOTE 1
Thermo sensor	1	—	10 (1.0, 7.2)	NOTE 1
Water hose band screw	8	—	1.3 (0.13, 0.9)	
<b>Fuel system:</b>				
Air cleaner housing cover mounting screw	6	5	1.8 (0.18, 1.3)	
Sub-air cleaner housing mounting bolt	2	5	2.5 (0.25, 1.8)	
Fuel valve tapping screw	2	5	10 (1.0, 7.2)	
Fuel unit mounting cap nut	4	6	10 (1.0, 7.2)	
Fuel tank rear mounting bracket bolt	1	8	22 (2.2, 16)	
Fuel tank mounting bolt	2	6	12 (1.2, 9)	
Fuel tank heat guard plate mounting screw	2	5	2.5 (0.25, 1.8)	
<b>Engine mount:</b>				
Engine mounting bolt (front upper)	2	8	27 (2.7, 20)	
(front upper)	1	10	45 (4.5, 32)	
(front lower)	1	10	45 (4.5, 32)	
(rear upper)	1	10	45 (4.5, 32)	
(rear lower)	1	10	55 (5.5, 39)	
Sub-frame mounting bolt (front)	2	10	45 (4.5, 32)	
(rear)	4	10	45 (4.5, 32)	
<b>Front suspension:</b>				
Handlebar upper holder bolt	4	8	27 (2.7, 20)	
Handlebar weight bolt	2	6	9 (0.9, 7)	NOTE 2
Throttle housing screw	2	5	4 (0.4, 2.9)	
Fork pinch bolt (upper)	2	8	27 (2.7, 20)	
Fork pinch bolt (lower)	4	8	35 (3.5, 25)	NOTE 6
Fork tube cap	2	35	23 (2.3, 17)	
Fork socket bolt	2	8	20 (2.0, 14)	NOTE 2
Anti-dive case cover bolt	4	6	9 (0.9, 7)	NOTE 2
'89—'90, '94:	4	5	4 (0.4, 2.9)	NOTE 2
After '94:	4	5	4 (0.4, 2.9)	NOTE 2
Steering bearing adjustment nut	1	26	25 (2.5, 18)	NOTE 6
Steering stem nut (flange nut)	1	24	105 (10.5, 76)	
Front axle nut	1	14	90 (9.0, 65)	
Front axle pinch bolt	4	8	22 (2.2, 16)	
Ignition switch mounting bolt	2	8	25 (2.5, 18)	NOTE 2



Item	Q'ty	Thread dia. (mm)	Torsque N·m (kg·m, ft·lb)	Remarks
<b>Frame (Cont'd)</b>				
<b>Rear suspension:</b>				
Rear axle nut (U-lock nut)	1	18	110 (11.0, 79)	
Rear axle pinch bolt (flange bolt)	1	8	27 (2.7, 20)	
Shock absorber upper mounting bolt (flange bolt)	2	8	27 (2.7, 20)	
Shock absorber lower mounting (L)	1	8	23 (2.3, 17)	
(R) (flange bolt)	1	10	35 (3.5, 25)	
Swingarm left pivot bolt	1	23	100 (10.0, 72)	
Swingarm right pivot bolt ('89 - '90, '94 - '96)	1	23	10 (1.0, 7.2)	
(After '96)	1	23	12 (1.2, 9)	
Swingarm right pivot lock nut	1	23	100 (10.0, 72)	
<b>Brake/clutch system:</b>				
Bleed valve	2	8	6 (0.6, 4.3)	
Brake/clutch oil bolt	7	10	35 (3.5, 25)	
Master cylinder holder bolt	4	6	12 (1.2, 9)	
Brake/clutch reservoir screw	4	4	1.5 (0.15, 1.1)	
Caliper mounting bolt (Right)	2	8	27 (2.7, 20)	
Caliper mounting bolt (Left)	1	8	27 (2.7, 20)	
Caliper pin bolt (flange bolt)	2	8	13 (1.3, 9)	
(inside hex head bolt)	2	8	23 (2.3, 17)	
Anti-dive piston bolt	1	6	12 (1.2, 9)	
Pad pin	2	10	17 (1.7, 12)	
Pad pin plug	2	10	3 (0.3, 1.8)	
Brake disc retaining bolt ('89 - '90, '94 - '96)	12	8	40 (4.0, 29)	
(After '96)	12	8	43 (4.3, 31)	
Rear brake pedal pinch bolt	1	8	27 (2.7, 20)	
Rear brake pedal torque rod bolt (brake panel side)	1	8	22 (2.2, 16)	
(swingarm side)	1	8	22 (2.2, 16)	
Rear brake pedal adjuster lock nut	1	6	8 (0.8, 6)	
Rear brake arm pinch bolt	1	8	27 (2.7, 20)	
<b>Final drive:</b>				
Final gear case mounting nut	4	10	65 (6.5, 43)	NOTE 10
Final gear case oil filler cap	1	30	12 (1.2, 9)	
Pinion bearing retainer	1	64	110 (11.0, 80)	
Pinion nut	1	16	110 (11.0, 80)	
Final gear case cover bolt	2	10	48 (4.8, 35)	NOTE 2
	6	8	26 (2.6, 19)	NOTE 2

General Information

Tools

Description	Tool Number	Applicability	Refer Section(s)
Oil filter wrench	07HAA—PJ70100		3
Vacuum gauge	07404—0030000		3
Oil pressure gauge	07506—3000000	07LMS—001000A or	3
Oil pressure gauge attachment	07510—4220100	M937B—021—XXXXX	3
		Equivalent commercially available in U.S.A.	3
Float level gauge	07401—0010000		5
Antifreeze tester	Commercially available		6
Cooling system tester	Commercially available		6
Holder attachment	07930—KA50100		8
Hydraulic tappet bleeder	07973—MJ00000		8
Valve guide reamer 6.612 mm	07984—ZE20001	07984—ZE20000	8
Valve seat cutter, 33 mm (45° IN)	07780—0010800	Equivalent commercially available in U.S.A.	8
Valve seat cutter, 42 mm (45° EX)	07780—0010900		8
Valve flat cutter, 33 mm (32° IN)	07780—0012900		8
Valve flat cutter, 42 mm (32° EX)	07780—0013000		8
Valve interior cutter, 30 mm (60° IN)	07780—0014000		8
Valve interior cutter, 42 mm (60° EX)	07780—0014400		8
Cutter holder, 6.6 mm	07781—0010201		8
Clutch center holder	07923—MB00000	Equivalent commercially available in U.S.A.	9
Main shaft holder	07923—6890101		9, 10
Primary gear holder	07924—ME90000	07924—MC70002	9
Gear holder	07724—0010100	Not available in U.S.A.	9
Main bearing remover attachment	07946—ME90100		10
Damper spring compressor	07964—ME90000	In U.S.A. use:	10
Assembly bolt		07965—1660200	10
Assembly collar		07965—1660300	10
Compressor seat		07967—9690200	10
Threaded adaptor		07965—KA30000	10
Snap ring pliers	07914—3230001		10
Snap ring pliers	07914—5670100	Equivalent commercially available in U.S.A.	10
Lock nut wrench, 30 x 64 mm	07916—MB00001		10
Disassembly/assembly tool	07965—3710101		10
Driver	07749—0010000		10, 11, 12, 13
Driver, 40 mm I.D.	07746—0030100		10
Attachment, 42 x 47 mm	07746—0010300		10, 11, 12, 13
Attachment, 52 x 55 mm	07746—0010400		10, 11, 12, 13
Attachment, 62 x 68 mm	07746—0010500		10
Attachment, 30 mm I.D.	07746—0030300		10
Pilot, 30 mm	07746—0040700		10
Pilot, 20 mm	07746—0040500		10, 13
Main bearing driver attachment	07946—ME90200		12
Bearing puller & driver attachment	07934—MB00000	07965—MB00100	11
Pinion joint holder	07926—ME90000		11
Pinion retainer wrench	07910—MA10100	07910—ME80000	11
Pinion puller set	07HMC—MM80100	07931—ME4010B	11
		07931—HB3020A	
		07HMC—MM8011A	
Holder joint attachment	07HMB—MM80100		11
Ball race & bearing driver attachment or Fork seal driver	07945—3330300	In U.S.A. use:	11
Attachment, 37 x 40 mm		07947—3710101	
Driver		07746—0010200	
		07749—0010000	
Oil seal remover	07948—4630100		11
Bearing race insert attachment	07931—4630300		11
Bearing driver attachment	07GAD—SD40101		11
Joint holder attachment	07HMB—MM80100		11

Cont'd	Description	Tool Number	Applicability	Refer Section(s)
	Fork seal driver attachment	07947—KF00100		12
	Fork seal driver weight	07947—KA50100		12
	Spherical bearing driver	07946—KA30200	07945—3710300 07746—0030200 07749—0010000 07746—0010700	12
	Steering stem socket	07916—3710100		12
	Bearing race remover	07946—3710500		12
	Steering stem driver	07946—MB00000		12
	Swingarm lock nut wrench	07908—ME90000		13
	Shock absorber compressor attachment	07959—MB10000		13
	Attachment, 32 x 35 mm	07746—0010100		13
	Shock absorber compressor	07959—3290001		13
	Universal bearing puller	07631—0010000	Equivalent commercially available in U.S.A.	17
	Flywheel holder	07925—ME90000	or Band strap wrench commercially available in U.S.A.	15, 17
	Rotor puller	07933—3950000		15, 17
	Digital multi tester (KOWA)	07411—0020000	Equivalent commercially available in U.S.A.	15, 16
	Analogue tester	07308—0020001 (SANWA) or TH—5H (KOWA)		17, 18

**General Information**

**Lubrication & Seal Points**

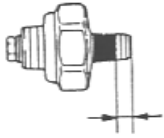
Engine	Location	Material	Remarks
	Right and left crankcase mating surface Cylinder head/cylinder head cover mating surface	Liquid sealant	Do not apply sealant around the hydraulic tappet holes.
	Shift fork claw Valve stem (valve guide sliding surface) Right and left crankcase main bearing Connecting rod bearing Camshaft journals and cam lobes M2/3, C3, C5 gear shift fork grooves Rocker arm slipper surface Rocker arm shaft surface Piston pin outer surface Spark plug sleeve threads and O-ring groove Transmission spline bushing Transmission M4, C2, C3 gear bushing Output gear damper shaft bushing Starter reduction shaft Clutch outer guide inner surface	Molybdenum disulfide oil	
	Oil pressure switch  3—4 mm (0.12—0.16 in) Ignition pulse generator grommet Camshaft plug	Sealant	Apply only to the area shown
	Oil filter boss (crankcase side threads) Cam sprocket bolt threads Ignition pulse generator bolt threads Oil pump driven sprocket bolt threads Starter oneway clutch socket bolt threads Shift drum bearing set plate bolt threads Crankcase bearing set plate bolt threads Gear shift cam bolt threads Gear shift stopper arm bolt threads Output drive shaft special bolt threads Alternator stator mounting bolt threads	Locking agent	Clean and apply to the threads.
	Piston pin hole inner surface Connecting rod small end All bearings Connecting rod bolt/All nut threads and flange surface Flywheel bolt threads Primary drive gear bolt threads Oil filter cartridge O-ring	Engine oil	
	Timing hole cap threads Oil seal lip	Multipurpose grease	
	Clutch slave cylinder piston seal	DOT 4 brake fluid	

Frame			
Location	Material	Remarks	
Main stand pivot Rear brake cam Steering stem upper bearing lower bearing dust seal Throttle pipe Swingarm pivot bearing Front wheel dust seal lips Speedometer gearbox Shock absorber preload adjuster inside surface	Multi-purpose grease		
Side stand pivot Final drive pinion joint spline Final driven flange spline Universal joint spline Drive shaft oil seal lip Anti-dive case needle bearing Trunk damper rod	Molybdenum disulfide grease		
Steering stem adjustment nut Fork pinch bolt (Lower)	Apply engine oil to the threads		
Right and left handle bar grip rubber Rear trunk seal rubber A seal rubber B seal grommet	Honda Hand Grip Cement (U.S.A. only)		
Thermo sensor Fan motor switch	Apply sealant to the threads		
Fork Fork dust seal lips oil seal lips Anti-dive case O-ring	Fork fluid		
Brake/clutch master piston/piston seals Caliper piston Caliper piston seals Brake/clutch reservoir	DOT 4 brake fluid	Apply to the sliding surface	
Caliper pin bolt rubber boots inside	Silicone grease		
Fork socket bolt Ignition switch mounting bolt Side stand switch mounting bolt Anti-dive case cover bolt Handlebar weight mounting bolt	Locking agent	Clean and apply to the threads	

# Cable & Harness Routing

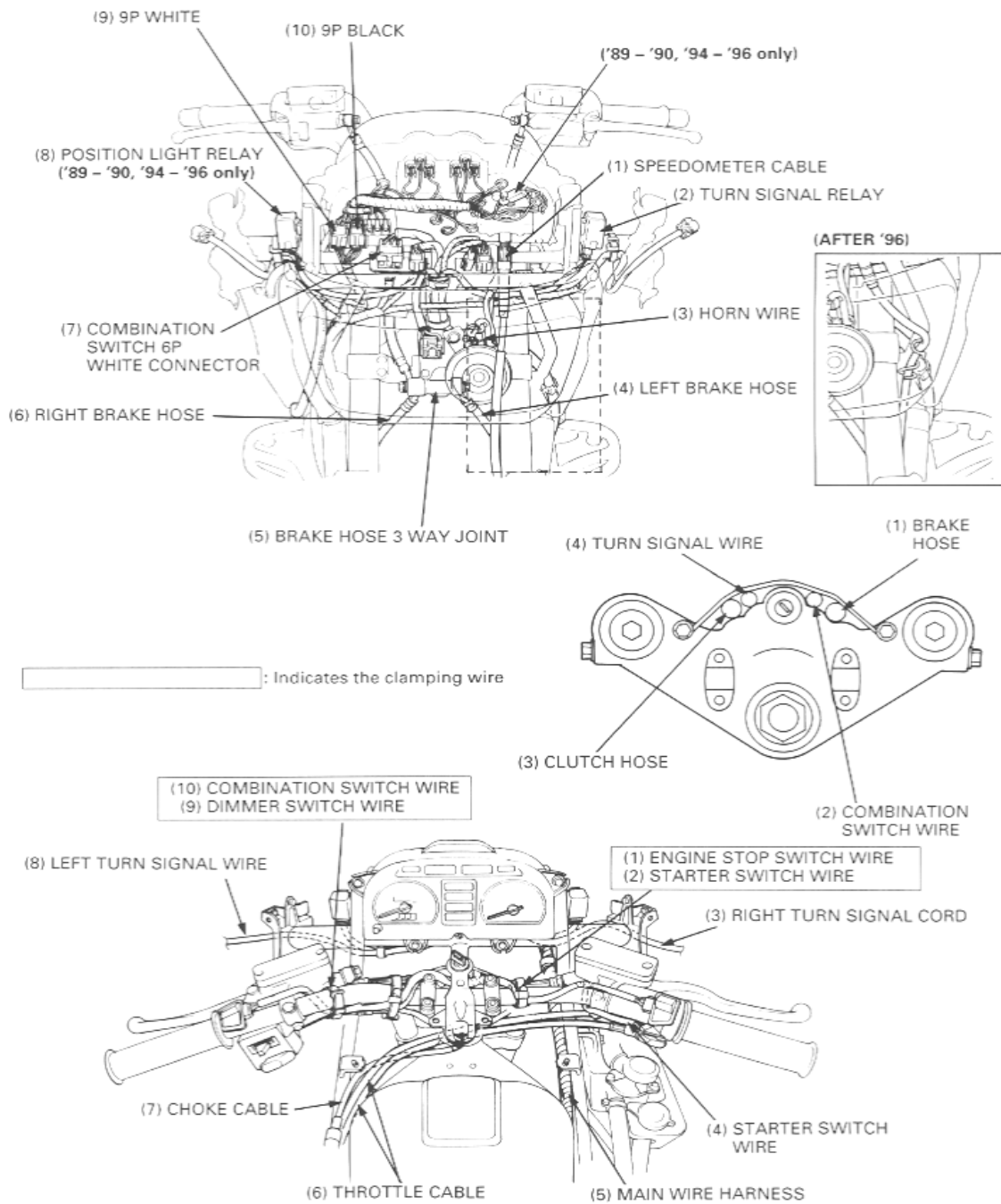

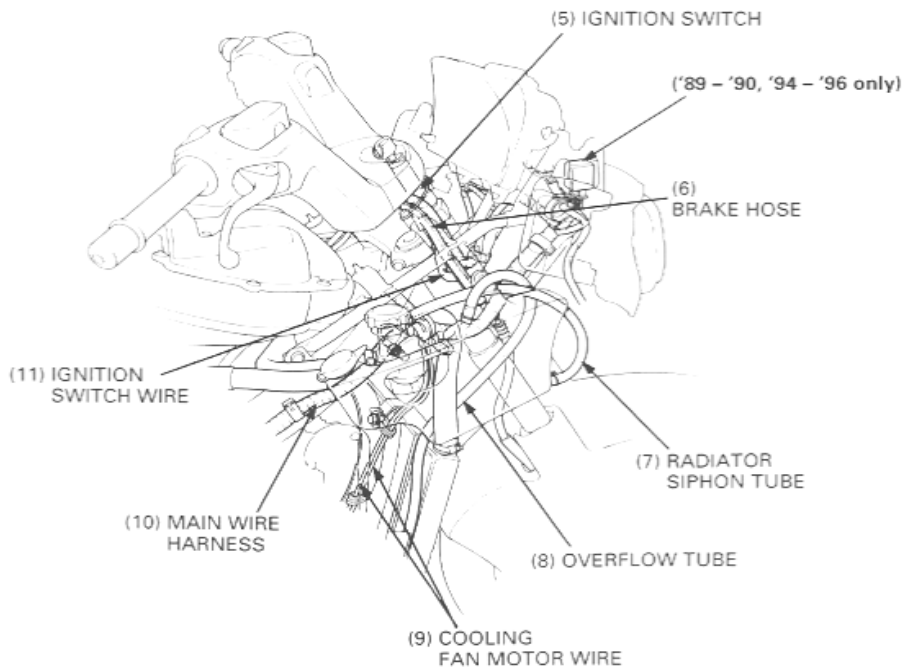
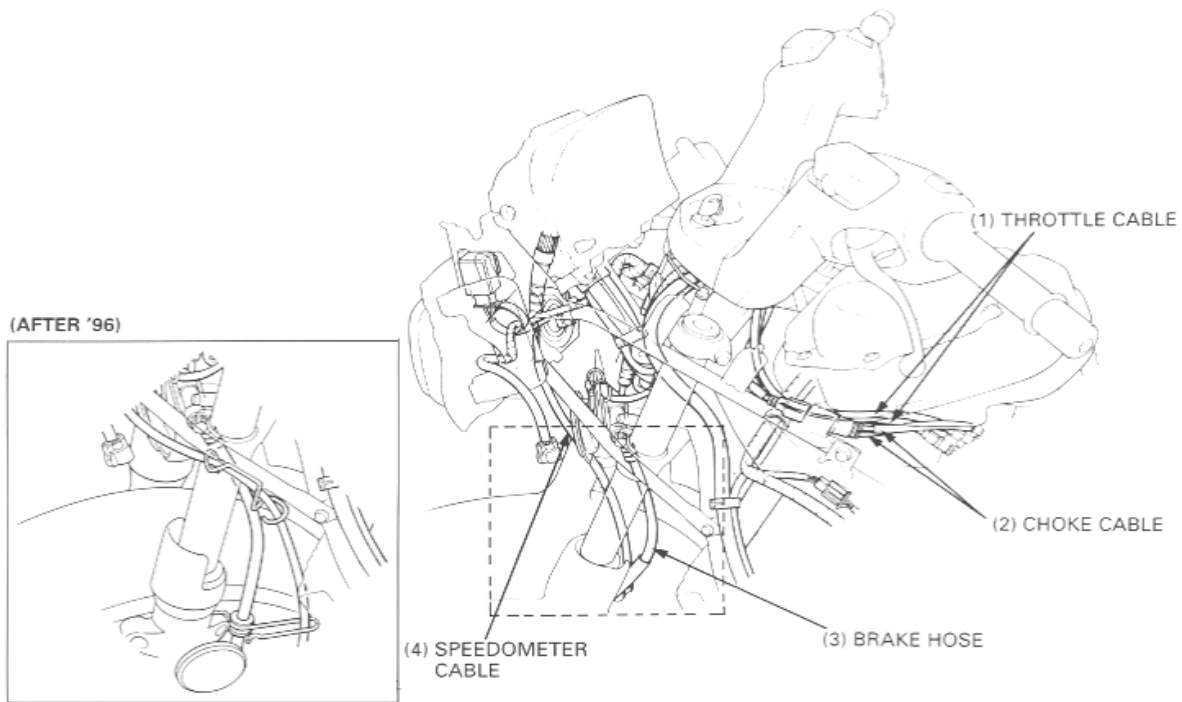

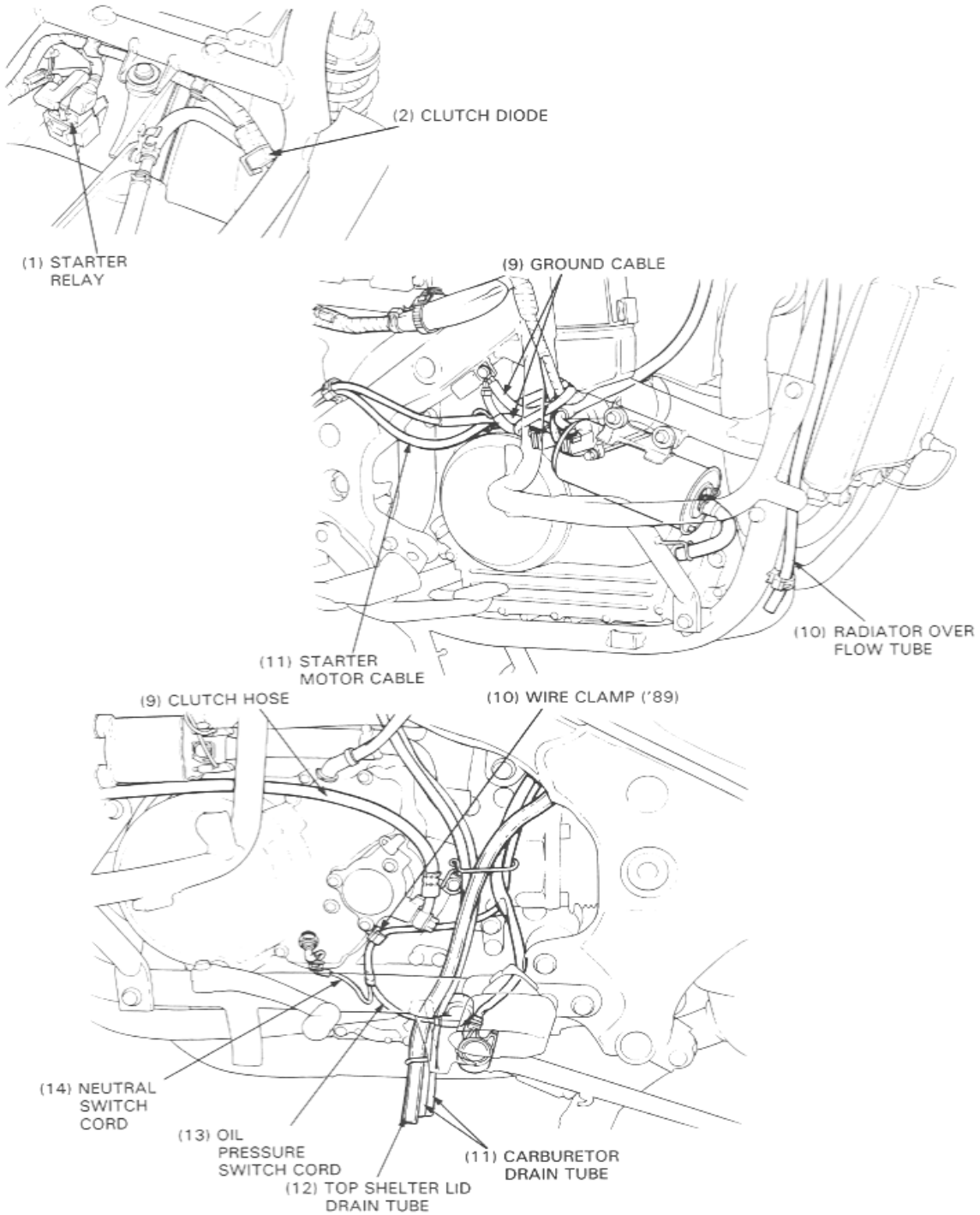

('89)

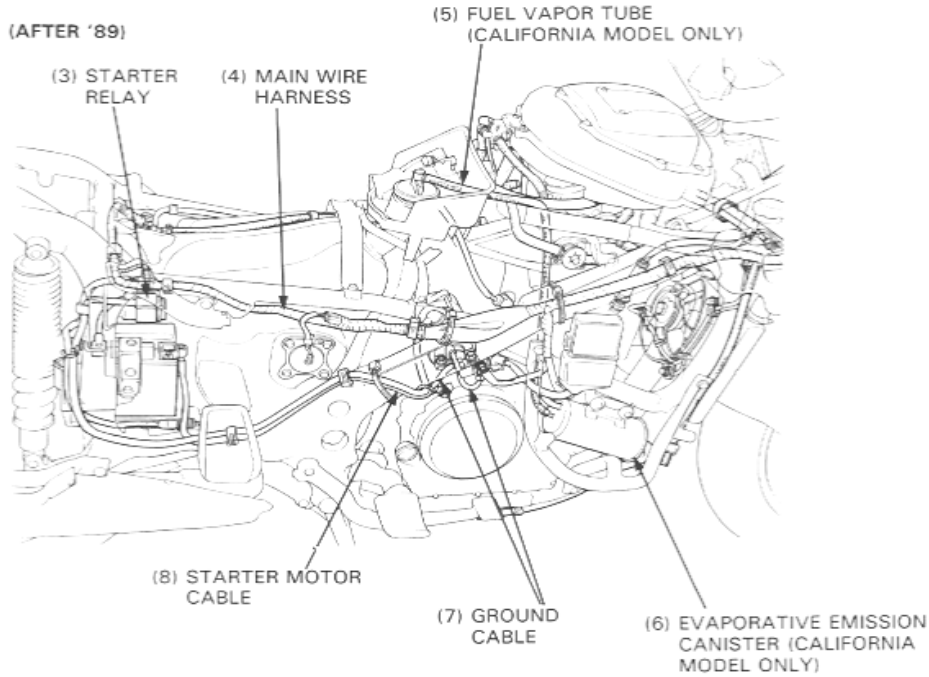
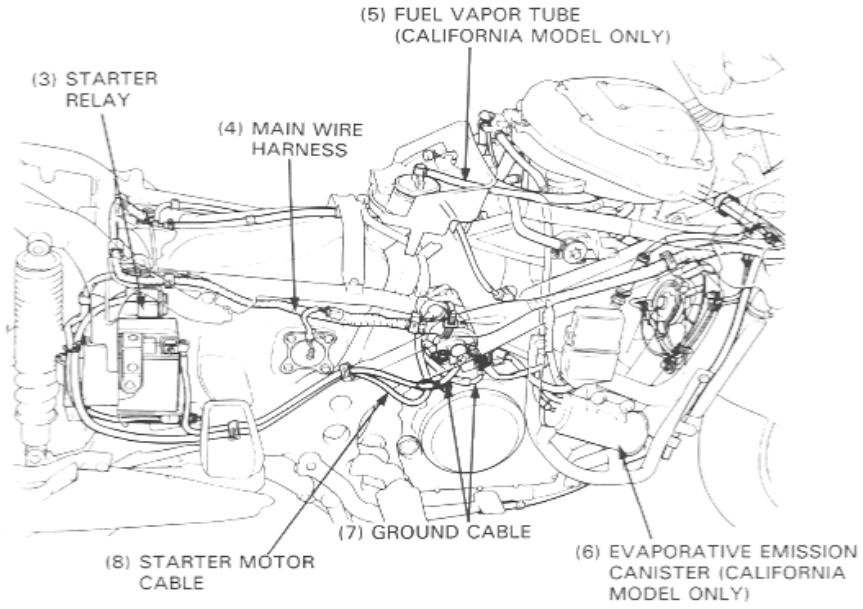

('89)

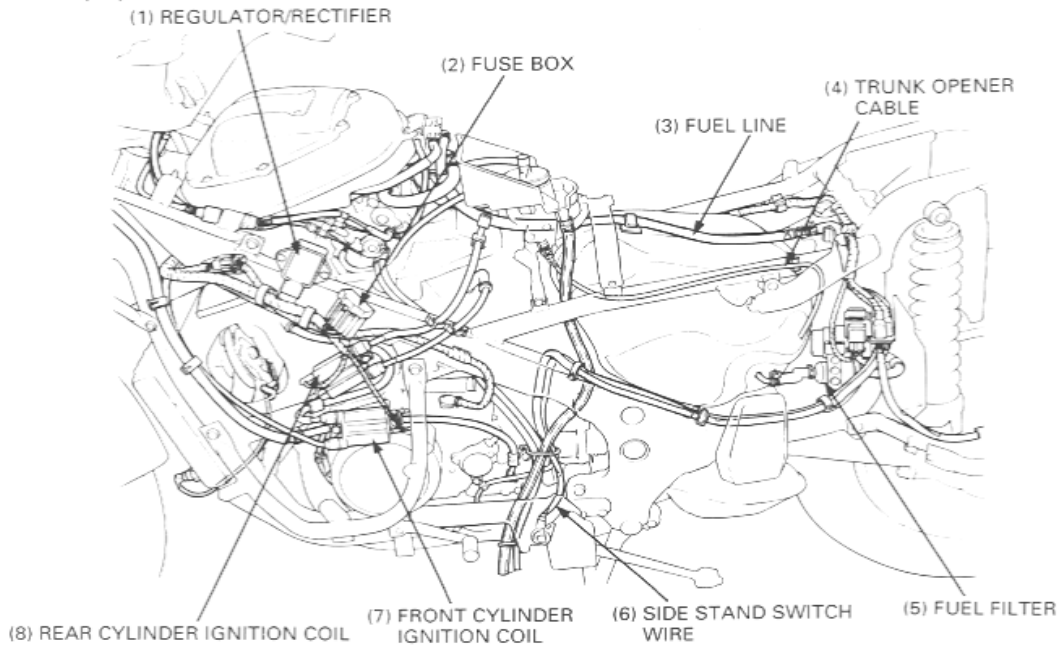

(AFTER '89)

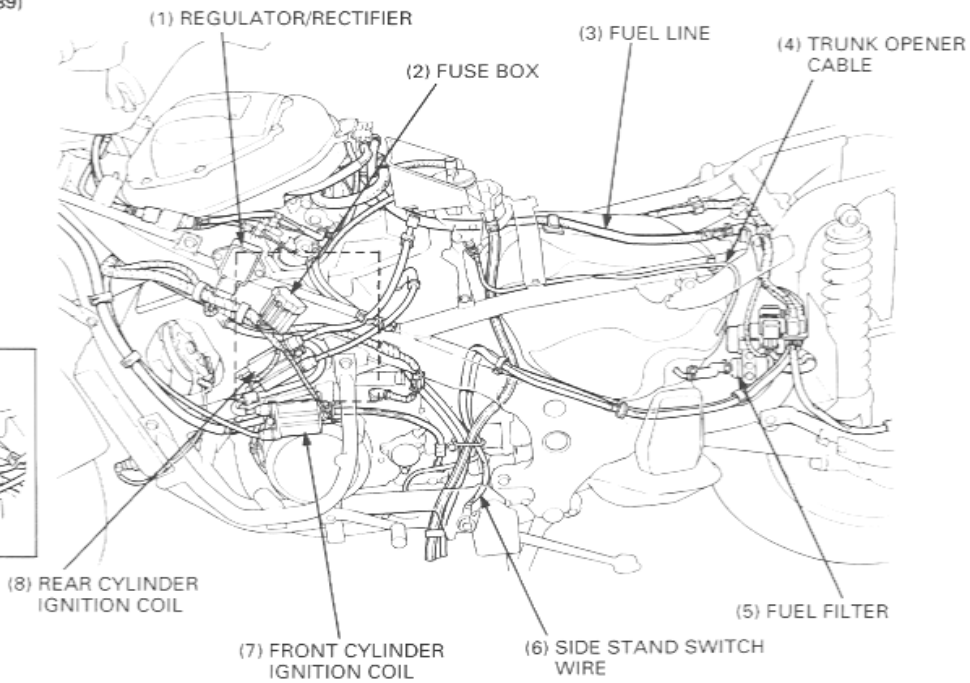

(After '96)

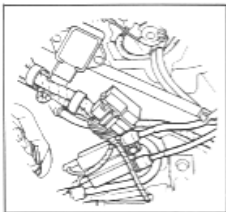

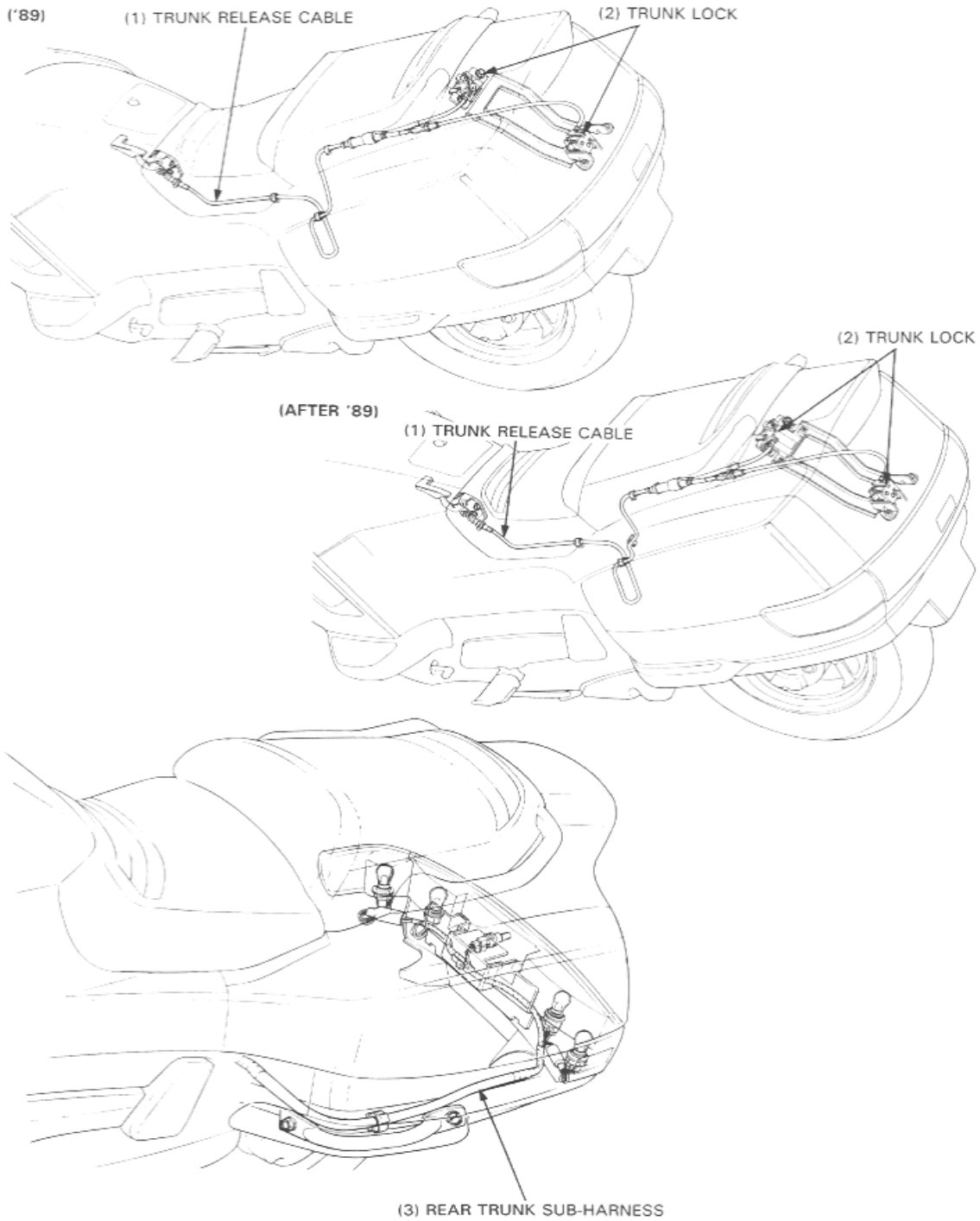

## Emission Control Systems

The U.S Environmental Protection Agency and California Air Resources Board (CARB) require manufactures to certify that their motorcycles comply with applicable exhaust emissions standards during their useful life, when operated and maintained according to the instructions provided, and that motorcycles built after January 1, 1983 comply with applicable noise emission standards for 1 year or 6,000 km (3,730 miles) after the time of sale to the ultimate purchaser, when operated and maintained according to the instructions provided. Compliance with the terms of the Distributor's Warranties for Honda Motorcycle Emission Control Systems is necessary in order to keep the emissions system warranty in effect.

### Source of Emissions

The combustion process produces carbon monoxide and hydrocarbons. Control of hydrocarbons is very important because, under certain conditions, they react to form photochemical smog when subjected to sunlight. Carbon monoxide does not react in the same way, but it is toxic.

Honda Motor Co., Ltd. uses lean carburetor settings as well as other systems, to reduce carbon monoxide and hydrocarbons.

### Exhaust Emission Control System

The exhaust emission control system is composed of a lean carburetor setting, and no adjustment should be made except idle speed adjustment with the throttle stop screw.

The exhaust emission control system is separate from the crankcase emission control system.

### Crankcase Emission Control System

The crankcase emission control system routes crankcase emissions through the air cleaner and into the combustion chamber. Condensed crankcase vapors are accumulated in an air/oil separator and drain tube which must be emptied periodically. Refer to the Maintenance Schedule (page 3-4).

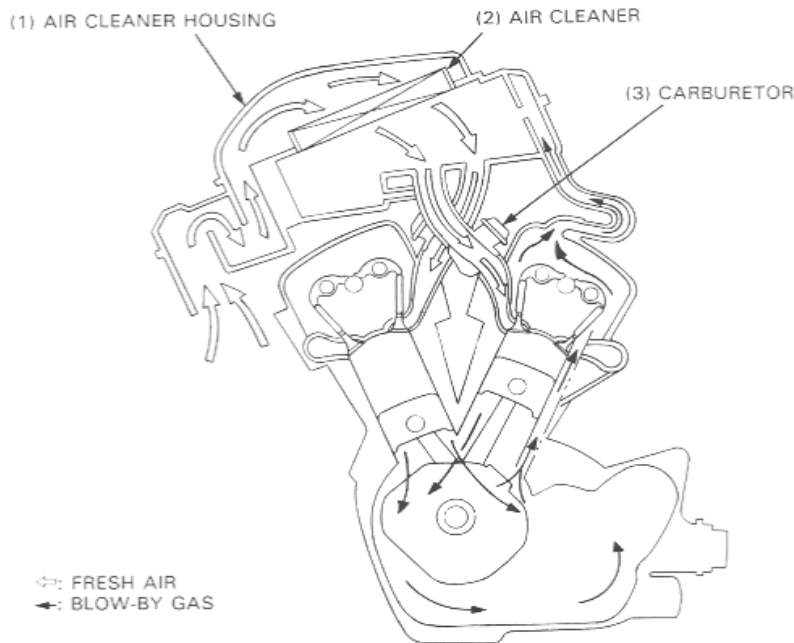

**Evaporative Emission (EVAP) Control System (California Model Only)**

This vehicle complies with the California Air Resources Board requirements for evaporative emission regulations.

Fuel vapor from the fuel tank and carburetors is routed into the evaporative emission (EVAP) canister where it is adsorbed and stored while the engine is stopped. When the engine is running and the (EVAP) purge control diaphragm valve is open fuel vapor in the (EVAP) canister is drawn into the engine through the carburetor. At the same time, the (EVAP) air vent control valve is open and air is drawn into the carburetor through the valve.

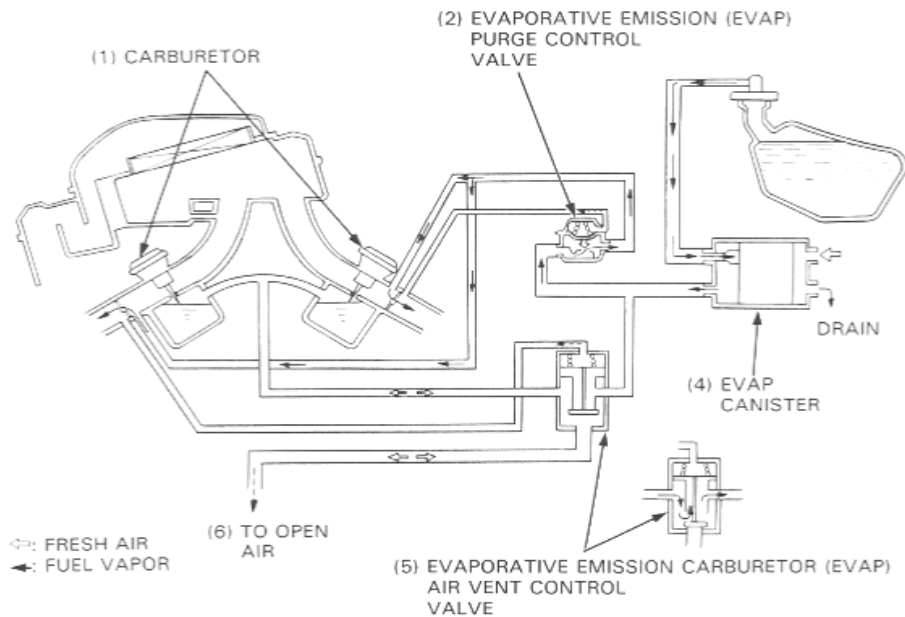

**Noise Emission Control System**

**TAMPERING WITH THE NOISE CONTROL SYSTEM IS PROHIBITED:** Federal law prohibits the following acts or the causing thereof: (1) The removal or rendering inoperative by any person, other than for purposes of maintenance, repair or replacement, of any device or element of design incorporated into any new vehicle for purpose of noise control prior to its sale or delivery to the ultimate purchaser or while it is in use; or (2) the use of the vehicle after such device or element of design has been removed or rendered inoperative by any person.

**Among Those Acts Presumed to Constitute Tampering are the Acts Listed Below:**

1. Removal of, or puncturing the muffler, baffles, header pipes or any other component which conduct exhaust gases.
2. Removal of, or puncturing of any parts of the intake system.
3. Lack of proper maintenance.
4. Replacing any moving parts of the vehicle, or parts of the exhaust or intake system, with parts other than those specified by the manufacturer.

## Emission Control Information Labels (U.S.A. Only)

An Emission Information Label is located on the right side of the frame as shown. The right side cover must be removed to read it. It gives basic tune-up specifications.

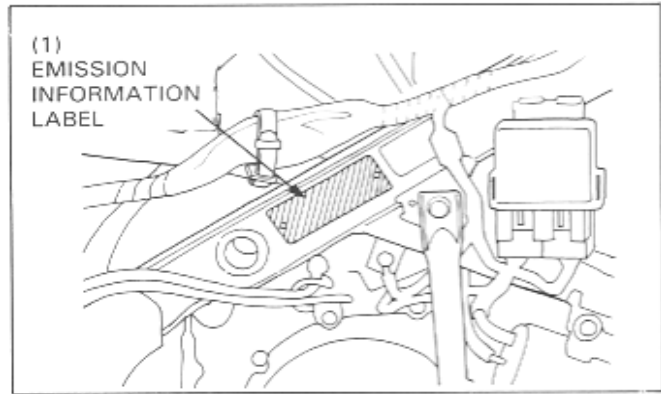

## Vehicle Emission Control Information Update Label

After making a high altitude carburetor adjustment, attach an update label on the right side of the frame.

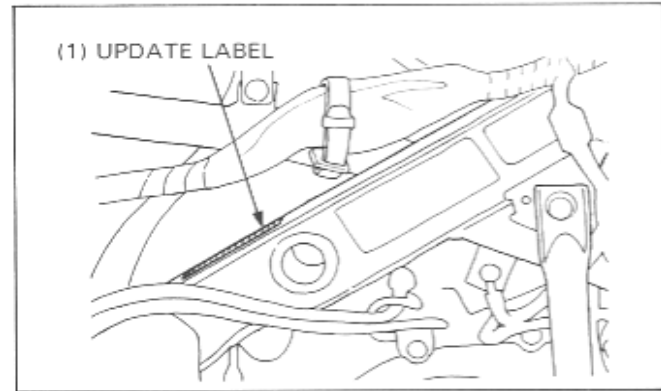

## Vacuum Hose Routing Diagram Label (California Model Only)

The Vacuum Hose Routing Diagram Label is on the left side of the fuel tank as shown. The left side cover must be removed to read it.

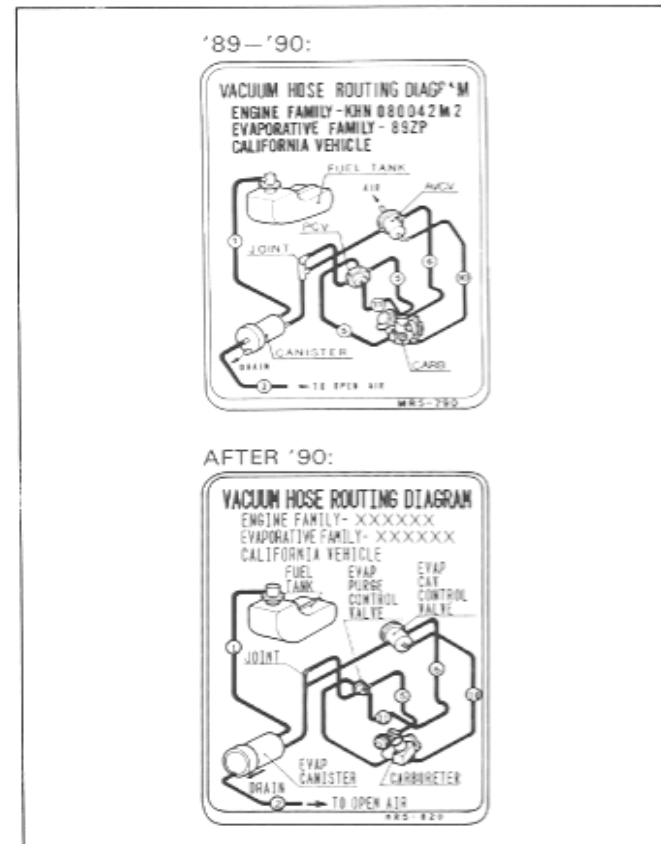
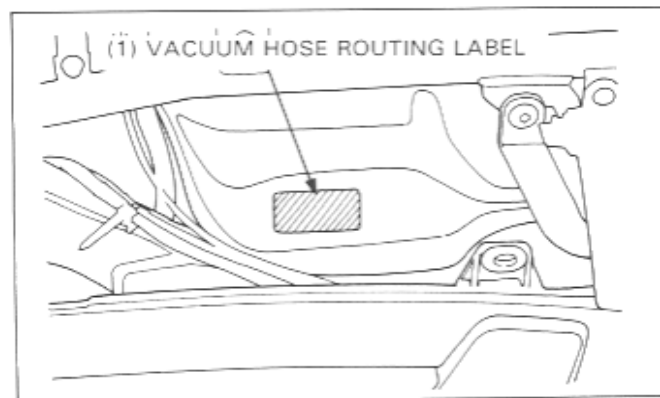

---

## 2. Frame/Body Panels/Exhaust System

Service Information	2-1	Exhaust System Removal/Installation	2-27
Troubleshooting	2-1	Fuel Tank Removal	2-30
Body Panels	2-2	Fuel Tank Installation	2-32

**2**

### Service Information

**▲ WARNING**

- Gasoline is extremely flammable and is explosive under certain conditions. Work in a well ventilated area with the engine stopped.  
Do not smoke or allow flames or sparks in the work area or where gasoline is stored.
- Serious burns may result if the exhaust system is not allowed to cool before components are removed or serviced.

- This section covers removal and installation of the frame body panels, fuel tank and exhaust system.
- Frame body panel installation is in the reverse order of removal, unless noted otherwise.  
When removing the cover, be careful not to damage any tab or groove of a cover.
- Always replace the exhaust pipe gaskets when removing the exhaust pipe from the engine.
- Note the positions of the clamps installed between the exhaust pipe and muffler; the tab on the clamp should align with the groove on the muffler.
- When installing the exhaust pipe, install the all fasteners loosely. Always tighten the exhaust clamps first, then tighten the mounting fasteners. If you tighten the mounting fasteners first, the exhaust pipe may not seat properly.
- Always inspect the exhaust system for leaks after installation.

### Troubleshooting

**Excessive Exhaust Noise**

- Broken exhaust system
- Exhaust gas leak

**Poor Performance**

- Deformed exhaust system
- Exhaust gas leak
- Clogged muffler

## Body Panels

### Body Panel Locations

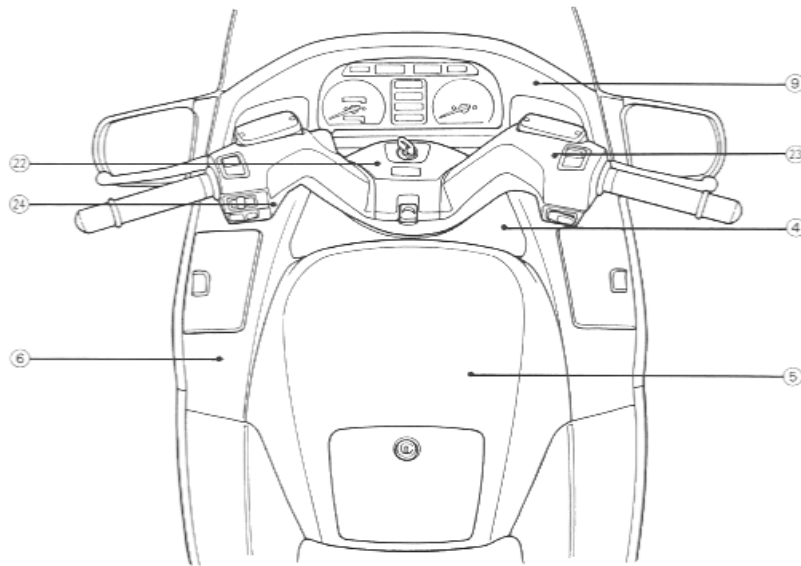
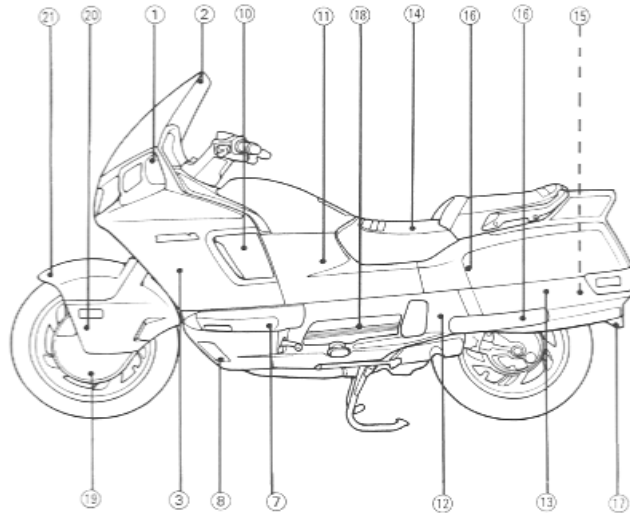

Frame Cover Removal Chart

- This chart shows removal order of frame covers.
- A chart line indicates removal of one part.

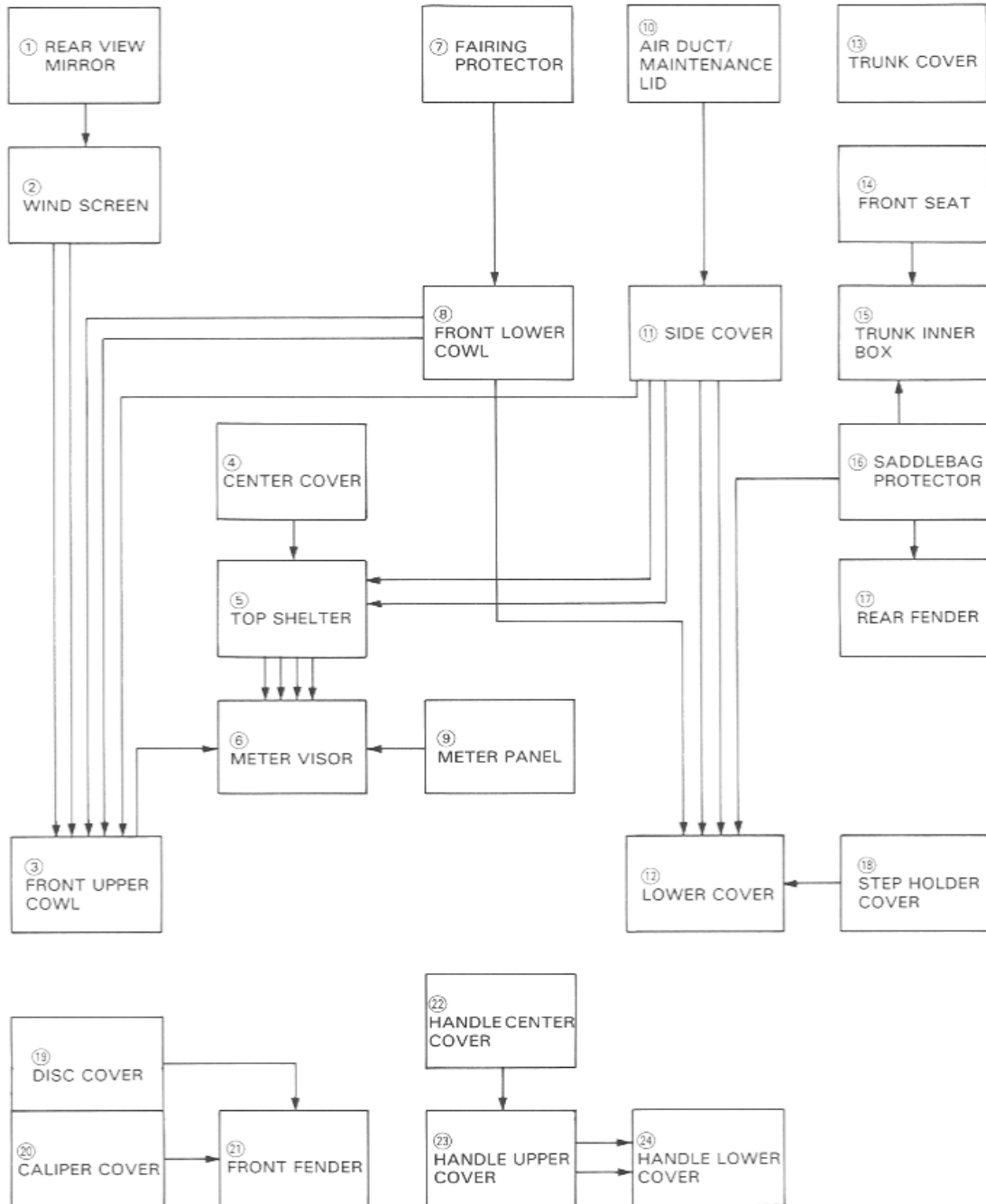

## Frame/Body Panels/Exhaust System

### Fairings

#### Air Duct/Maintenance Lid

Pull the air duct/maintenance lid until the clips are removed from the front fairing clip holder.  
Pull the air duct/maintenance lid out and rearward as shown.

#### NOTE

- The exhaust pipe becomes very hot during operation and remains hot after stopping the engine. Do not bring the cover into contact with the exhaust pipe when removing it.
- During removal, hold the air duct/maintenance lid at point A.

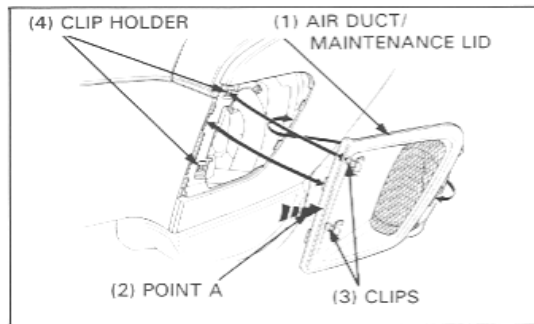

#### Side Cover

Remove the air duct.  
Remove the tapping screws.  
Release the side cover front claws from the front fairing.

Release the boss from the top shelter rubber grommet.  
Release the bosses from the lower cover rubber hole, then remove the side cover.

#### NOTE

- When installing the side cover, install the rear bosses of the side cover first, then install the front claws.

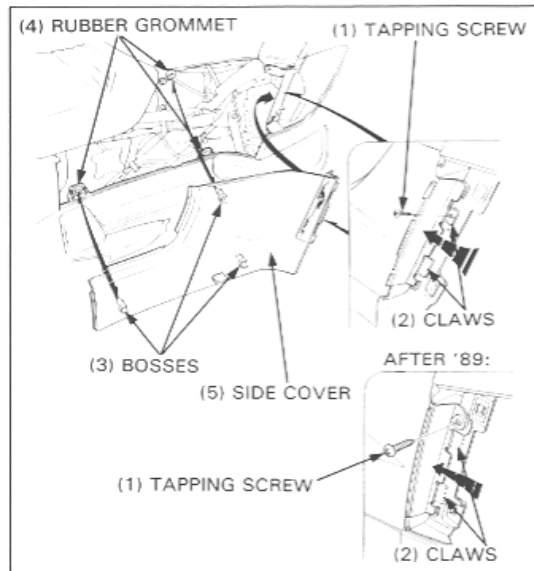

#### Fairing Protector

Remove the socket head bolt.  
Pull and remove the fairing protector from the front bumper.

#### NOTE ('89)

- During removal, squeeze the fairing protector at point A, then release the tabs from the front cowls and lower cover.

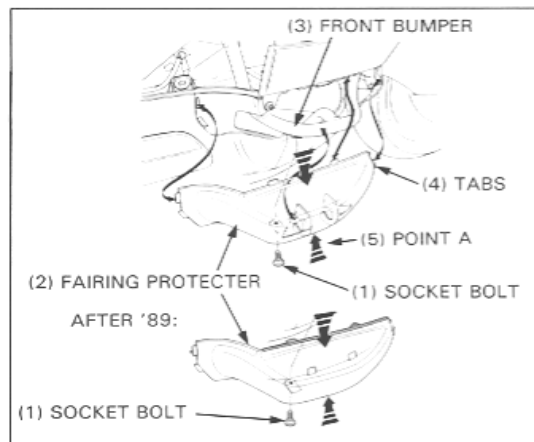

**Front Lower Cowl**

Remove the following:

- air duct
- side cover
- fairing protector

Remove the socket head bolts then remove the front lower cowl.

**NOTE**

- When installing the front lower cowl, align the front lower covers tabs with the lower cover grooves.

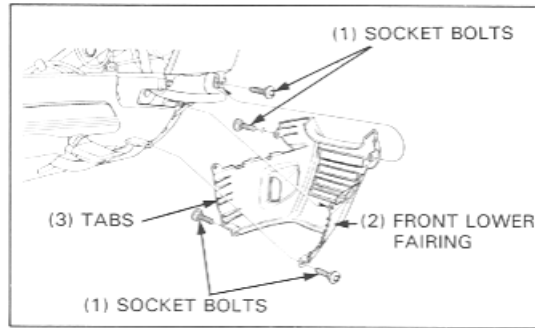

**Saddlebag Protector**

Pull and remove the saddlebag protector from the rear bumper.

**NOTE**

- During removal, squeeze the saddlebag protector at point A, then release the tabs from the lower cover and trunk cover.

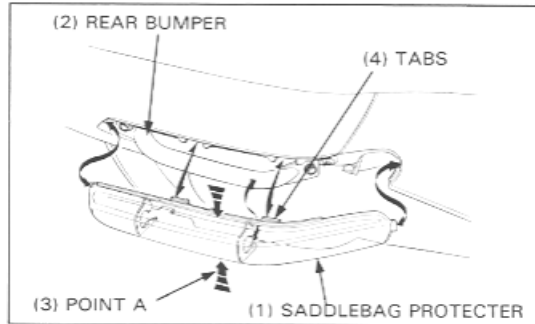

**Step Holder Cover**

Fold the passenger footpeg down.

Pull on the rear of the step holder cover and release the boss from the frame rubber grommet.

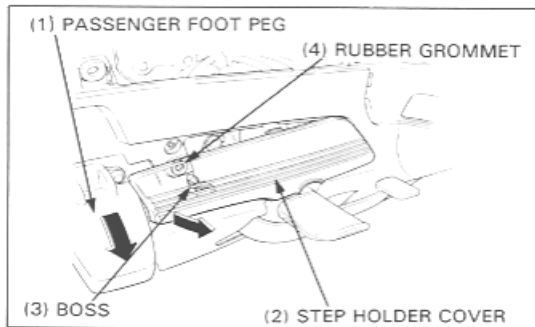

Release the tabs from the lower cover, then remove the step holder cover.

**NOTE**

- When installing the step holder cover, install the tabs first then install the boss into the lower cover rubber grommet.

AFTER '89:

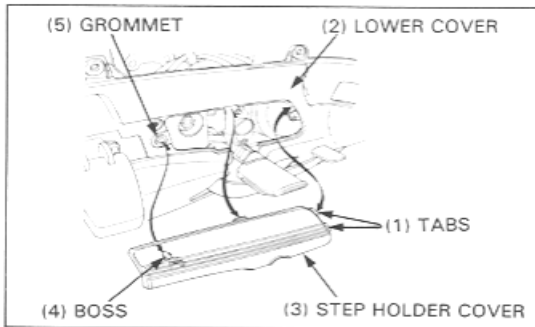

## Frame/Body Panels/Exhaust System

### Right Lower Cover

Remove the following:

- air duct
- side cover
- fairing protector
- saddlebag protector

'89:

Remove the two socket head bolts and the screw.

AFTER '89:

Remove the two socket head bolts and one collar.  
Remove the screw and washer.

Fold the passenger footpeg down.

Release the retaining hook at the rear of the cover.

Pull the lower cover down and out until it can be removed from the passenger footpeg.

Fold the passenger footpeg up, then remove the lower cover from the footpeg and brake pedal.

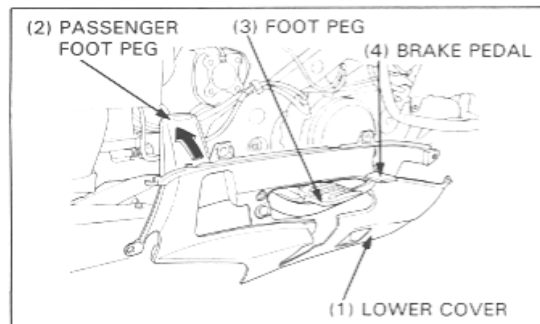
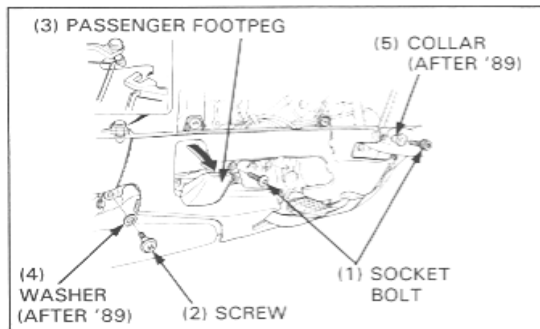

### Left Lower Cover

Remove the following:

- air duct
- side cover
- fairing protector
- saddlebag protector

'89:

Remove the two socket head bolts and the screw.

AFTER '89:

Remove the two socket head bolts.  
Remove the screw and washer.

Fold the passenger footpeg down.

Release the retaining hook at the rear of the cover.

'89:

Remove the two socket head bolts and the screw.

AFTER '89:

Remove the two socket head bolts, and one collar.  
Remove the screw and washer.

'89 – '90, '94 – '96:

Remove the chamber cover mounting bolt.

Fold the passenger footpeg down.

Release the retaining hook at the rear of the cover.

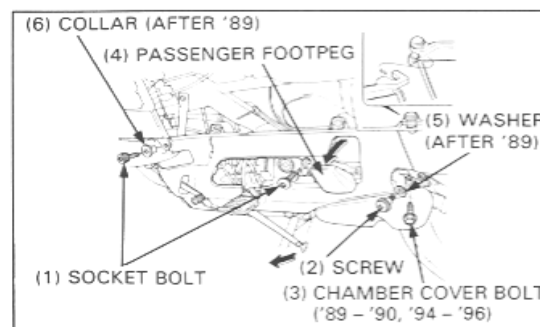
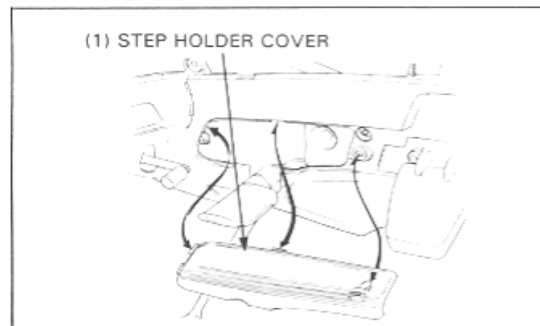

Pull the lower cover out and down until it can be removed from the passenger footpeg.  
Fold the passenger footpeg up.

Turn the lower cover about 90 degrees, then remove the lower cover and the chamber cover as an assembly from the gearshift pedal.

**NOTE**

- For easy removal, remove the gearshift pedal and position the side stand in the UP position.

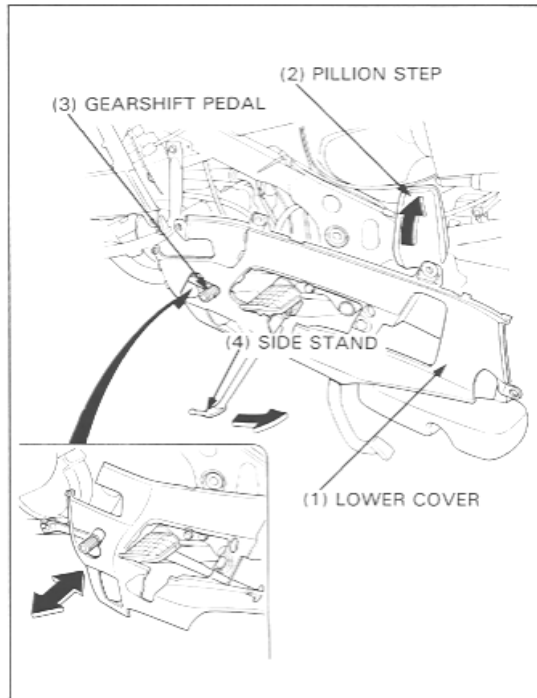

**Rear View Mirror**

Hold the rear view mirror, then remove the two bolts and the collars ('89).  
Release the rear view mirror from the upper fairing bracket.

Disconnect the front turn signal connector, then remove the rear view mirror.

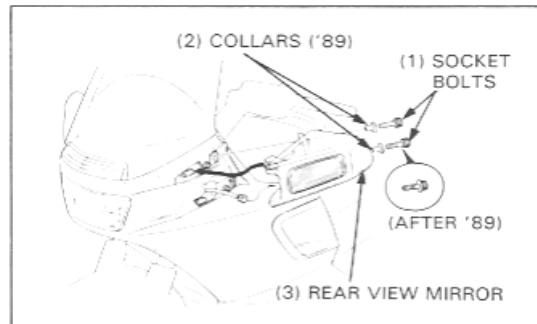

If the motorcycle was dropped and the mirror disconnected from the break-away mount, reinstall the rear view mirror according to the following procedure.

Remove the two socket bolts, collars ('89) and the mirror base.  
Remove the three special screws from the mirror bracket.

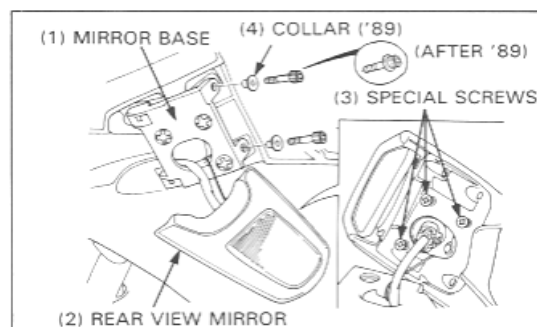

## Frame/Body Panels/Exhaust System

Position the mirror base on the mirror bracket, and install using the three special screws.

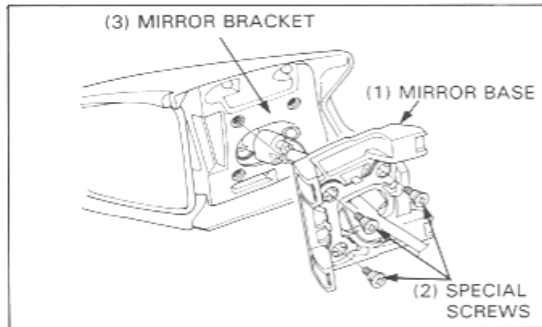

Reinstall the rear view mirror.

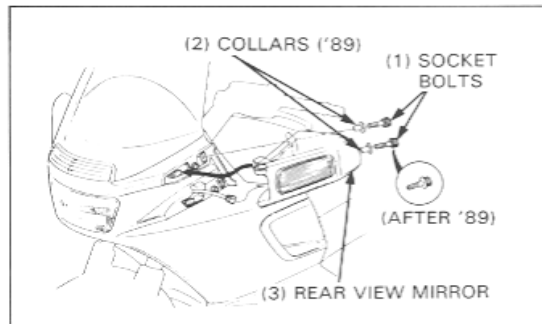

## Windscreen

Remove the mirrors (page 2-7).

Remove the two self tapping screws and the air duct.

Remove the two socket bolts and the windscreen garnish.

### NOTE

- Be careful not to damage the tabs.

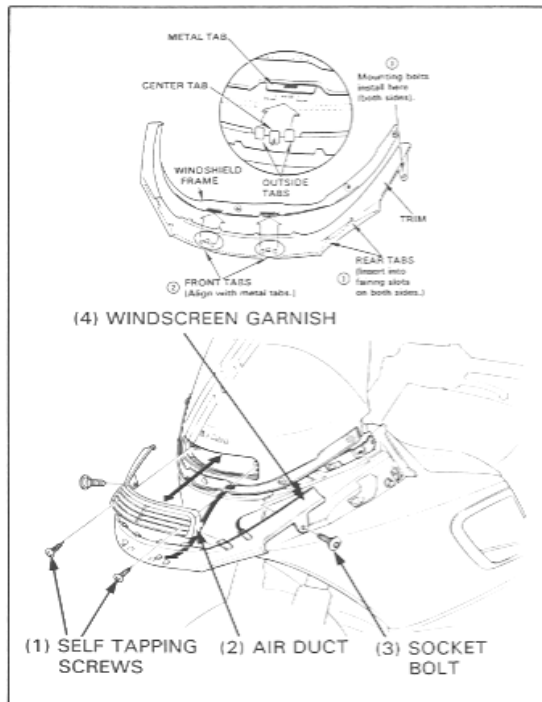

Remove the five screws and collars.  
Remove the windscreen frame, screen and the rubber seat.

**NOTE**

- At installation, set the gold collars into the each end of the screen hole.

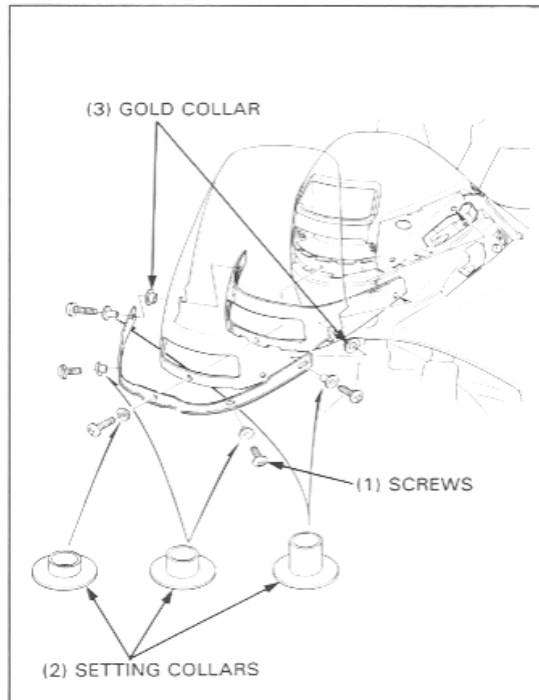

Remove the two screws and the screen air ducts.

**AFTER '89:**

Remove the two screws and the screen air duct A.  
Lift up on the screen air duct B and unhook the tabs from the holes.  
Pull down and remove the air duct.  
Installation is the reverse order of removal.

**AFTER '89:**

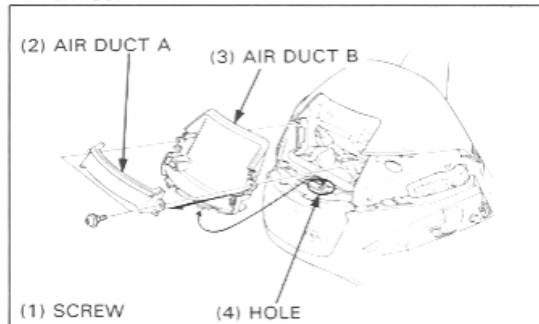

**Top Shelter/Meter Visor**

**Top Shelter**

- Remove the following:
- mirrors (page 2-7)
  - windscreen garnish (page 2-8)
  - windscreen (page 2-8)
  - both side covers (page 2-4)
  - both air ducts (page 2-4)

Release the bosses from the meter panel rubber holes, then remove the center covers.

**NOTE**

- When removing the center cover, remove the left cover first, then remove the right cover.
- At installation, align the right center covers tab with the left center cover groove.

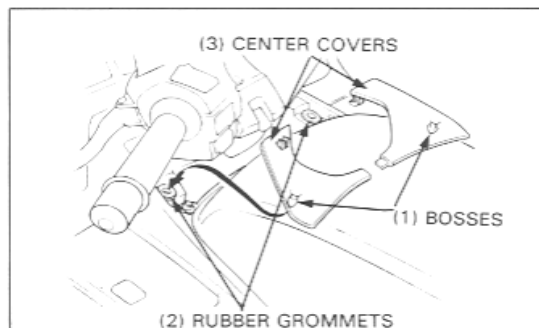

## Frame/Body Panels/Exhaust System

Remove the two flange bolts and loosen the two flange nuts.

Release the tabs and remove the top shelter by moving it rearward.

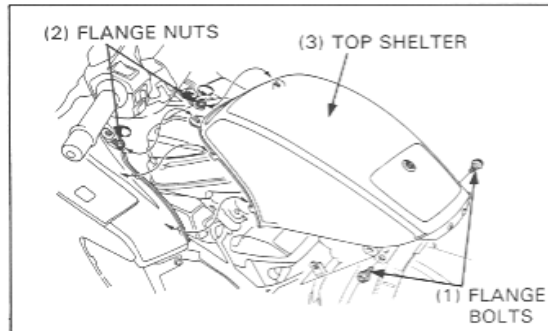

### Meter Panel

Remove the meter panel lid using a small flat blade screwdriver.

Remove the two self tapping screws.

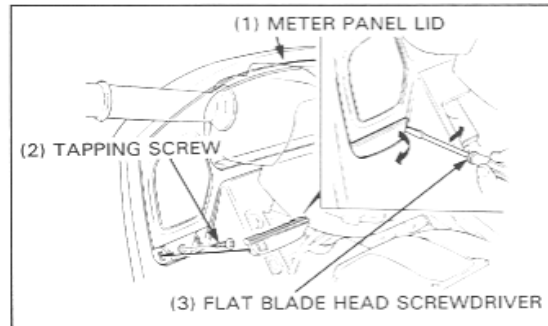

First release the meter panel lower tabs from the meter visor, then the upper tabs and the meter panel.

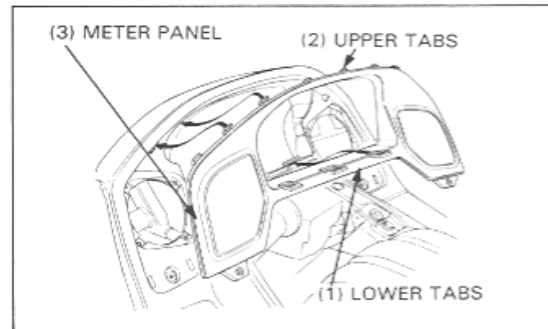

At installation, first install the upper tabs (B to F) as shown.

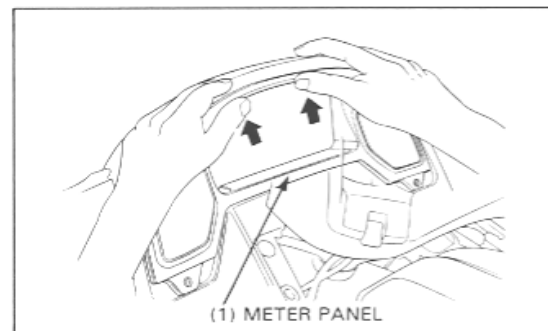
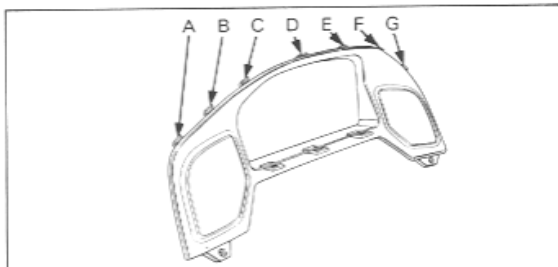

Install the upper tab A and G while holding the center of the meter panel.

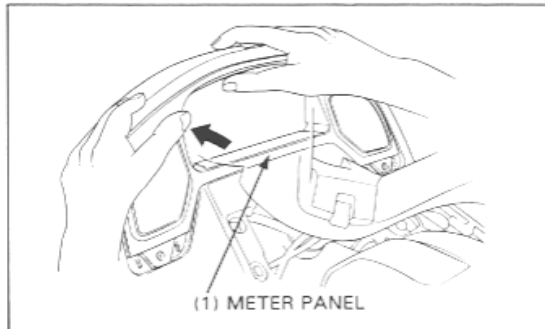

After install the upper tabs, install the lower tabs into the meter visor groove.

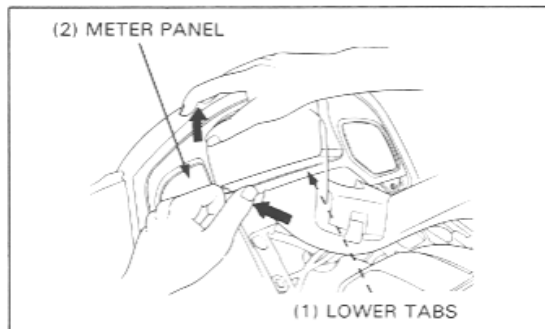

**Front Upper Cowl**

- Remove the following:
- both air ducts (page 2-4)
  - both side covers (page 2-4)
  - mirrors (page 2-7)
  - windscreen garnish (page 2-8)
  - lower cowl (page 2-5)
  - fairing protectors (page 2-4)
  - top shelter (page 2-10)

Remove the two trim clips.  
Release the tabs from the upper fairing grooves and remove the front center panel.

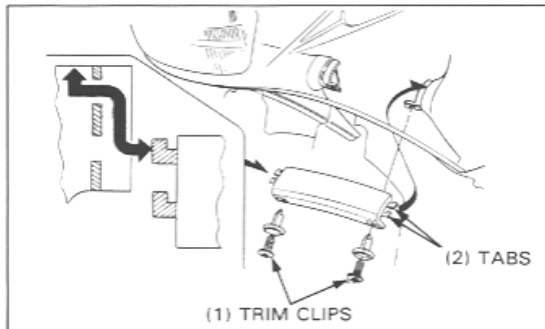

Open the fairing pocket lids.  
Remove the two mounting screws.  
Remove the six socket bolts and two collars and the front upper cowl mounting.

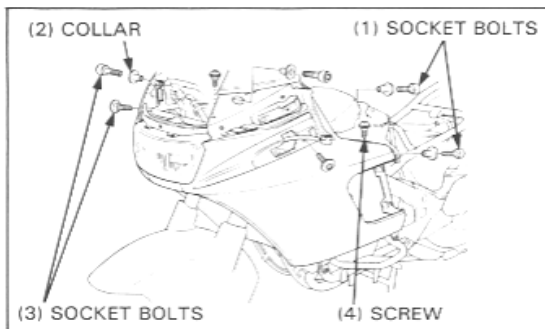

## Frame/Body Panels/Exhaust System

Disconnect the headlight connector.  
Remove the speedometer cable from the clamp.

Release the tabs from the meter visor, then remove the front upper cowl and headlight as an assembly.

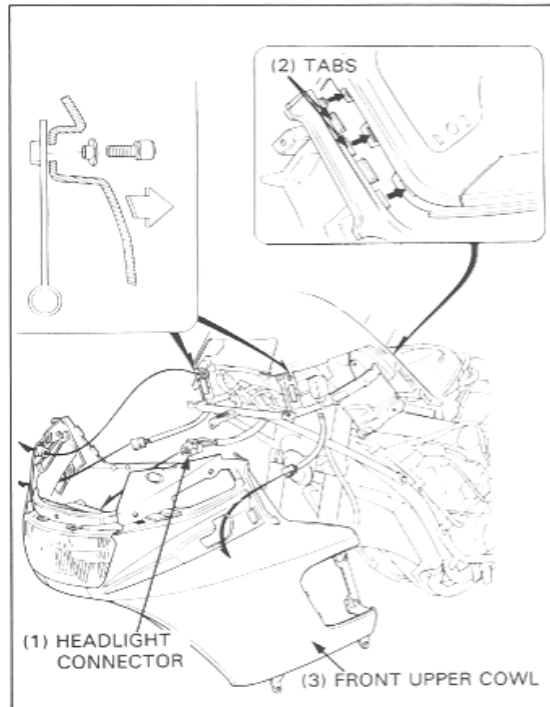

Remove the three screws and the front maintenance lid.  
Remove the six self tapping screws and the headlight.

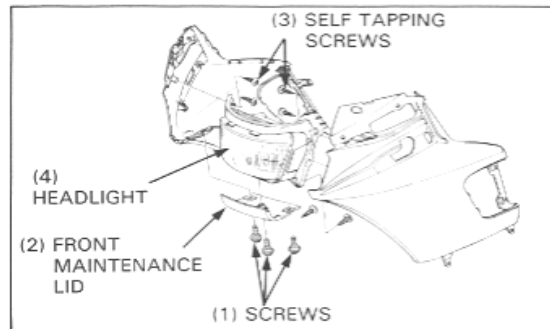

Remove the three self tapping screws and inner panel.

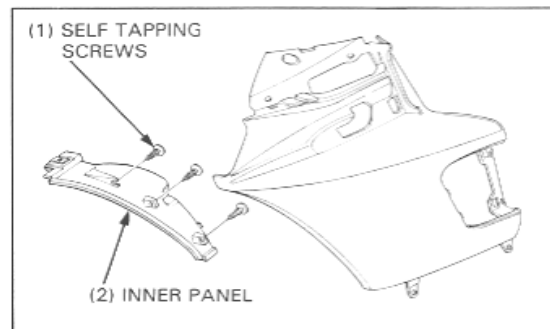

**Meter Visor**

Remove the front upper cowl (page 2-11).

Remove the two self tapping screws and four flange nuts.

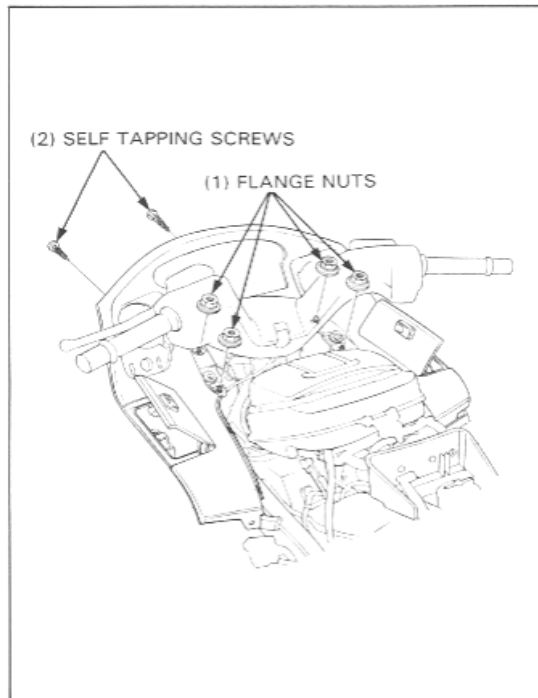

Remove the meter visor from the frame.

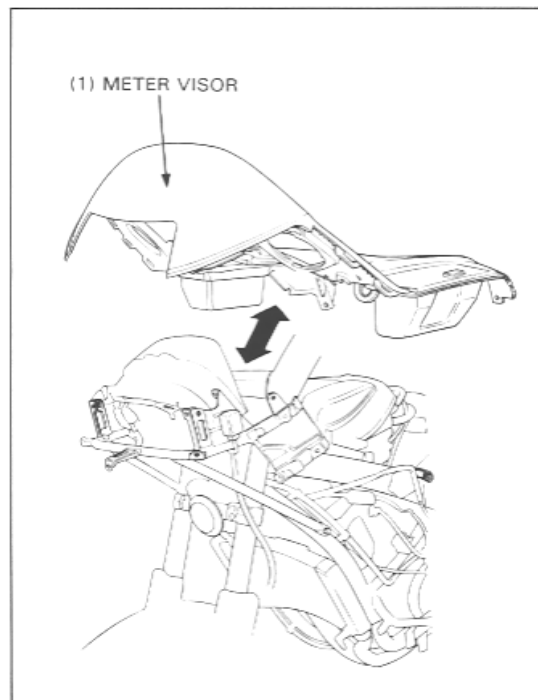

Front Fender

Caliper Cover/Disc Cover ('89 - '90, '94 - '96)

Remove the two socket head bolts from each cover.  
Remove the boss and the tabs, then the caliper cover and disc cover as an assembly.

NOTE

- Be careful not to damage the tabs.

'89:

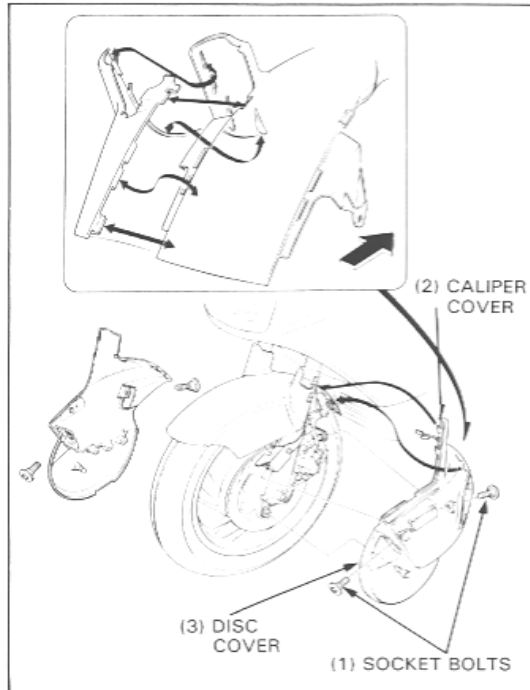

'90, '94 - '96:

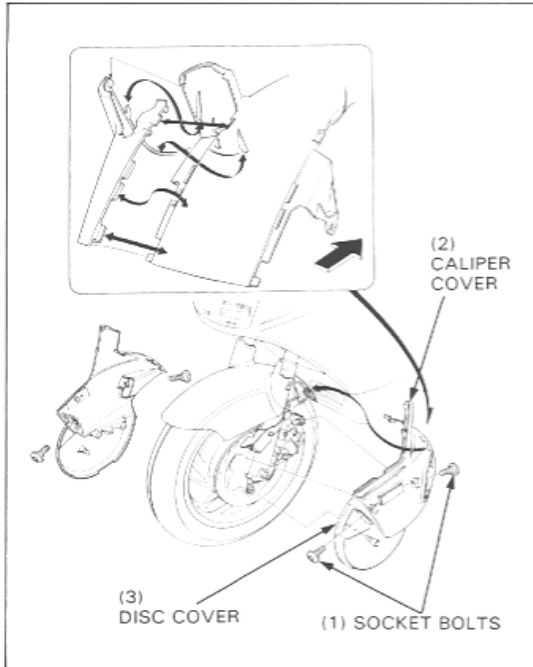

Remove the six self tapping screws and separate the disc cover and caliper cover.

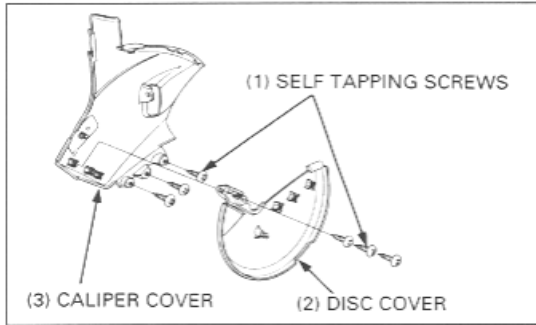

**Front Fender**

'89 - '90, '94 - '96:

Remove the four socket bolts and the front fender from the fork legs.

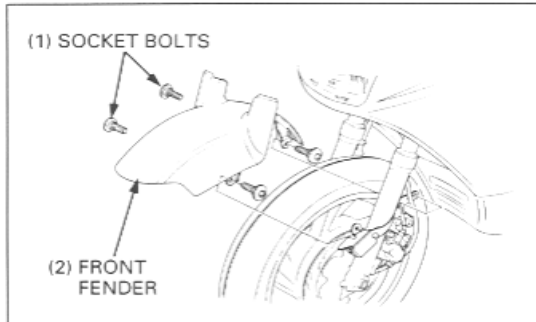

After '96:

Unscrew and remove the reflectors on both sides.

Remove the four socket bolts, front fender, stabilizer and brake hose guides.

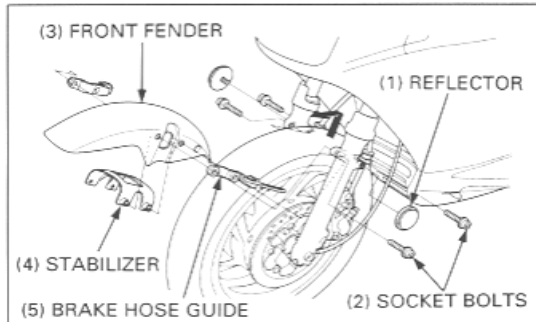

**Handlebar Covers**

Release the boss and tabs, and remove the handlebar center cover.

**NOTE**

- When installing, be sure the center cover is positioned properly over the ignition switch. The cover must be positioned so the boss and tabs line up correctly. After aligning the tabs, gently press down on the cover until it snaps into the place.

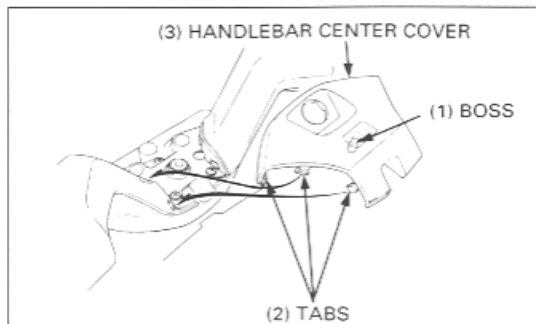

## Frame/Body Panels/Exhaust System

Remove the three screws attaching the handlebar upper cover.

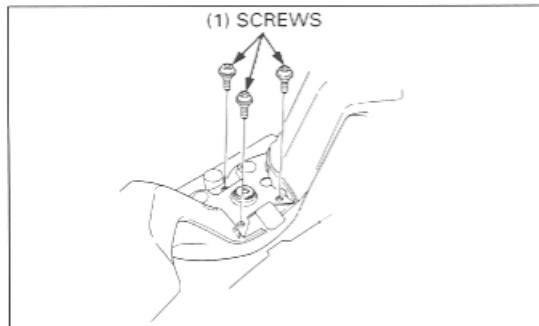

Remove the six self tapping screws, separate the upper and lower handlebar cover.

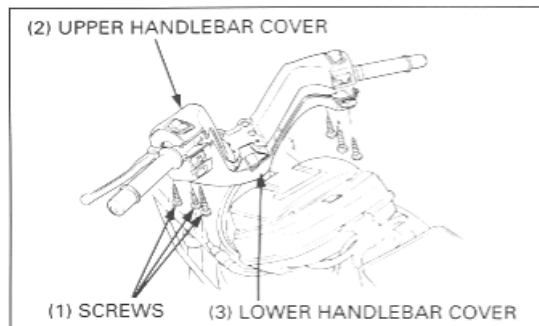

At installation, align the pin of the upper handle cover with the hole in the lower cover and with the hooks of the upper and lower covers.

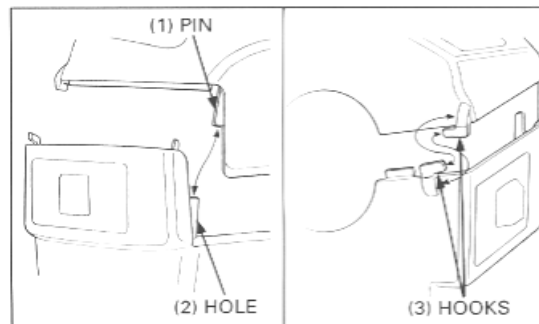

Remove the three self tapping screws and the combination switch.

Disconnect the dimmer switch connector.

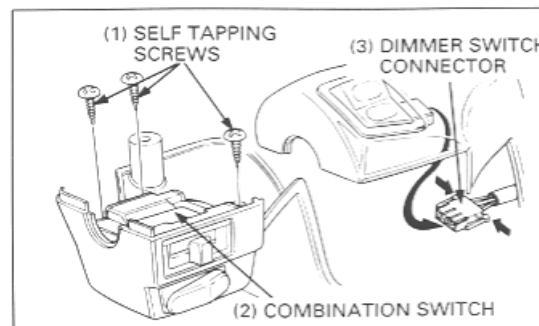

## Frame/Body Panels/Exhaust System

Remove the starter switch and disconnect the switch connector.

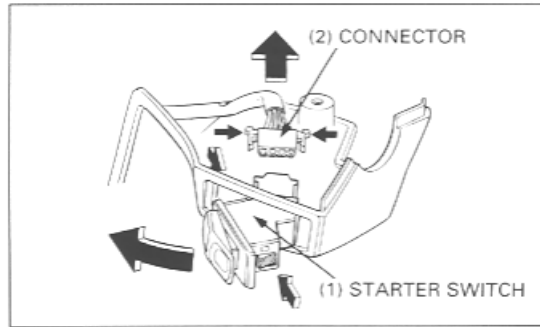

Disconnect the engine stop switch connector.  
Remove the upper and lower handlebar covers.

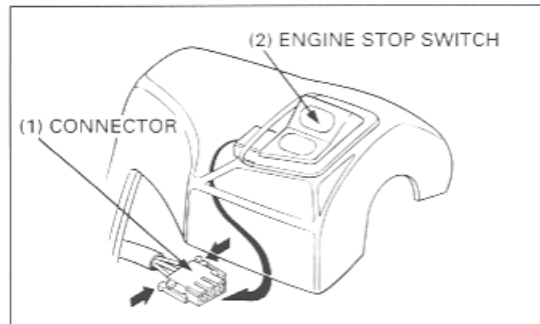

Remove the dimmer and engine stop switch from the cover.

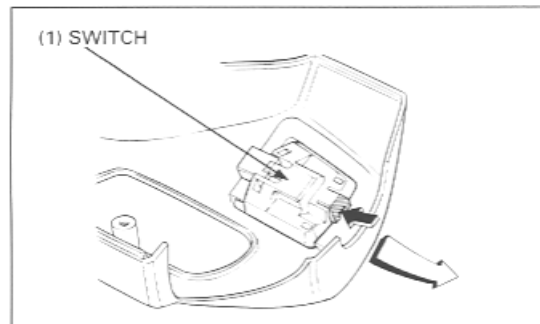

### Trunk

#### Front Seat

Open the trunk lid.  
Remove the two front seat mounting bolts.

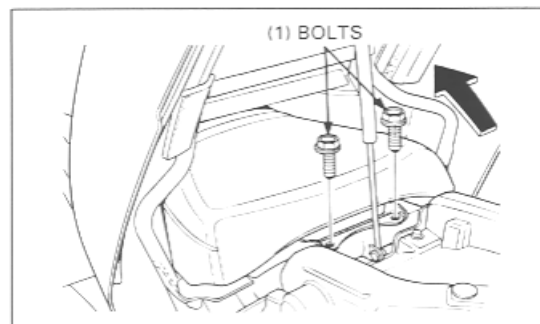

## Frame/Body Panels/Exhaust System

Slide the seat back, release the seat hook from the frame. Close the trunk lid half way, then remove the seat.

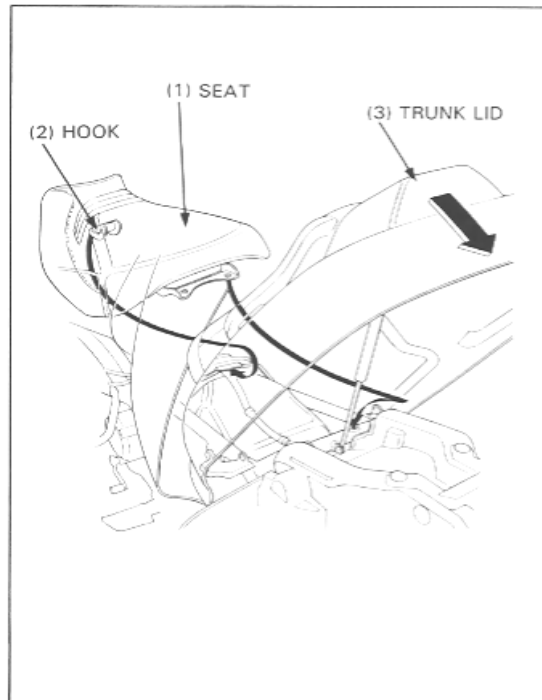

### Trunk Lid

Open the trunk lid.  
Remove the trunk damper stopper pins and collars.

Support the trunk lid so there is no tension on the damper mounting pins, then remove the trunk damper unit.

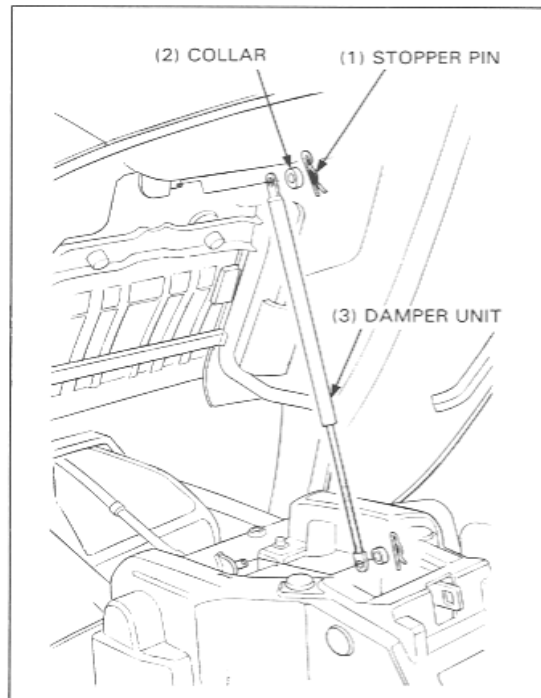

Close the trunk lid.  
Remove the trunk lid frame mounting socket bolts.

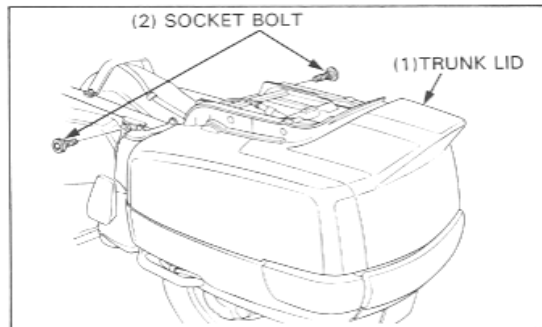

Release the trunk lock.  
Loosen the lock nut and then remove the trunk opener cable from the trunk opener and side rail.

Remove the trunk lid assembly from the frame.

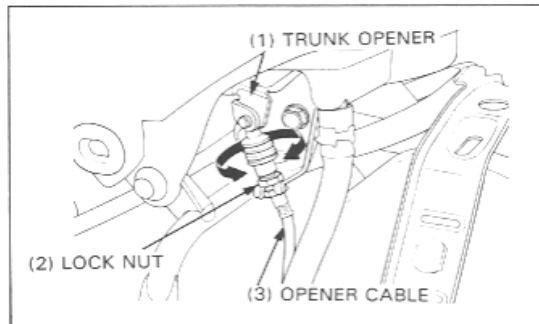

**Installation**

Installation is in the reverse order of removal.

**NOTE**

- At trunk lid damper installation, install the lower mount first, then install the upper mount by compressing the damper.
- Apply a locking agent to the trunk lid assembly mounting socket head bolts threads.

**Torque:**

Trunk lid assembly mounting bolt:  
27 N·m (2.7 kg·m, 20 ft·lb)

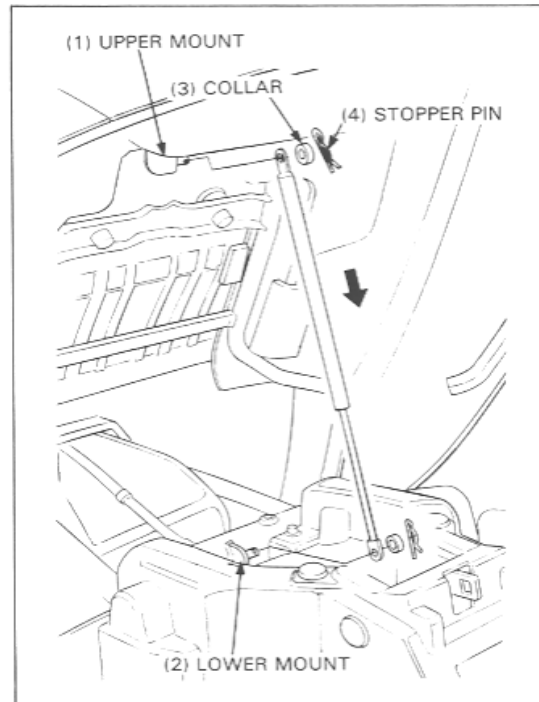

## Frame/Body Panels/Exhaust System

### Assembly Removal

When servicing the rear shock absorber or fuel tank, remove the rear trunk assembly as follows.

#### NOTE

- If a helper is not available, remove the individual components as instructed.

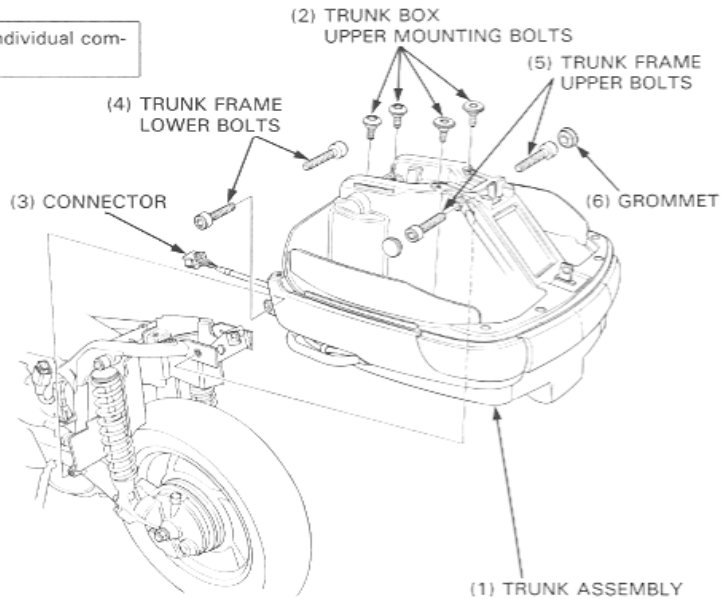

Remove the right and left saddlebag protectors (page 2-5).  
Remove the left and right lower cover screws and rubber top fasteners.  
Remove the four trunk box upper mounting socket head bolts.  
Disconnect the rear turn signal and brake light harness connector (located at rear of left side cover).  
Support the trunk assembly, remove the two trunk frame lower mounting socket head bolt.  
Remove the grommet and the two trunk frame upper mounting bolts.

Remove the trunk assembly from the frame.

At installation, apply silicone sealer around the trunk box mounting bolt holes and tighten the bolts specified torque.

#### Torque:

Trunk box upper mounting bolts:  
10 N·m (1.0 kg-m, 7.2 ft-lb)  
Trunk frame mounting bolts  
(upper): 55 N·m (5.5 kg-m, 39 ft-lb)  
(lower): 55 N·m (5.5 kg-m, 39 ft-lb)

### Individual Components Removal

#### Rear Fender

Open the trunk lid.  
Remove the two socket head bolts.  
Release the two bosses from the rear sub-frame.

Disconnect the right rear turn signal connector.

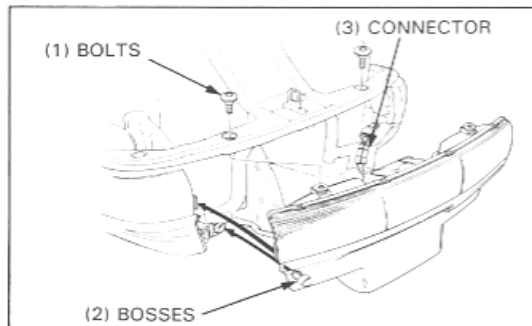

Disconnect the connectors, then remove the wire harness from the tail/brake unit.  
Remove the tail/brake light and the rear fender as an assembly.

At installation, tighten the socket head bolts specified torque.

**Torque: 7 N·m (0.7 kg-m, 5 ft-lb)**

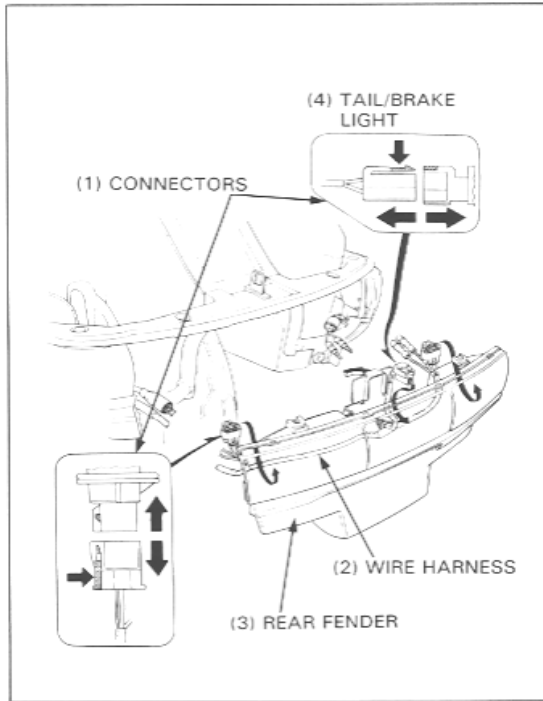

Disassemble the tail/brake lens and the rear fender as shown.

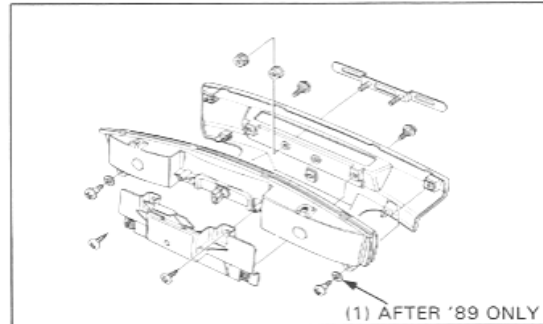

**Trunk Cover**

Remove the rear fender.  
Remove the saddlebag protector (page 2-5).  
Open the trunk cover.

'89:  
Remove the three self tapping screws and the inside cover.

AFTER '89:  
Remove the three self tapping screws, protect covers and washers, then the inside cover.

Remove the mounting screw.  
Release the rubber hole from the boss and remove the cover.

**NOTE**

- At installation, first install the tab into the frame rubber grommet.

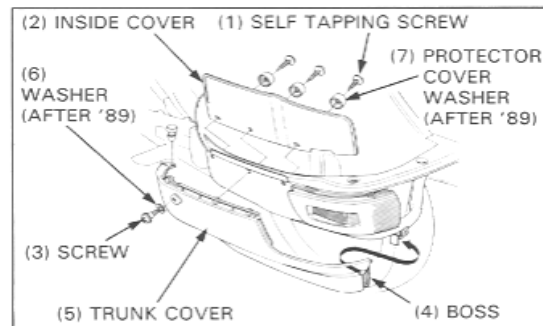

## Frame/Body Panels/Exhaust System

### Rear Turn Signal

Remove the rear turn signal mounting socket head bolt. Release the boss from the sub-frame and remove the rear turn signal.

At installation, tighten the socket head bolts specified torque.

**Torque: 7 N·m (0.7 kg-m, 5 ft-lb)**

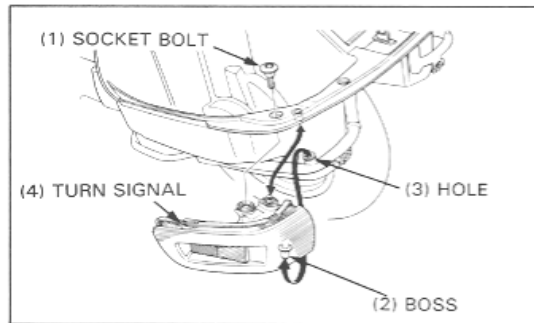

### Trunk Box

Remove the trunk lid (page 2-18).

Remove the four upper mounting socket head bolts. Remove the upper and lower trunk frame mounting bolts and the trunk box assembly.

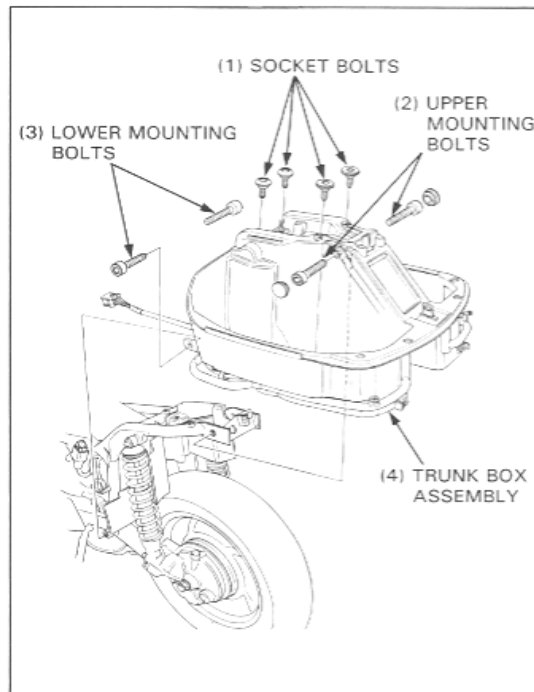

'89:

Remove the two special bolts and nuts.

AFTER '89:

Remove the two special bolts, nuts and washers. Remove the trunk box from the frame.

At installation, tighten the bolts specified torque.

**Torque:**

Trunk box upper mounting bolts:

10 N·m (1.0 kg-m, 7.2 ft-lb)

side mounting bolts:

10 N·m (1.0 kg-m, 7.2 ft-lb)

Trunk frame mounting bolts

(upper): 55 N·m (5.5 kg-m, 39 ft-lb)

(lower): 55 N·m (5.5 kg-m, 39 ft-lb)

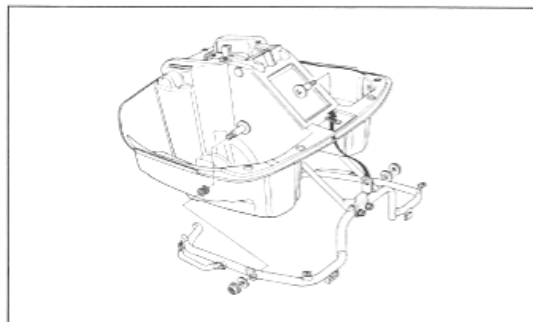

Trunk Release System

'89:

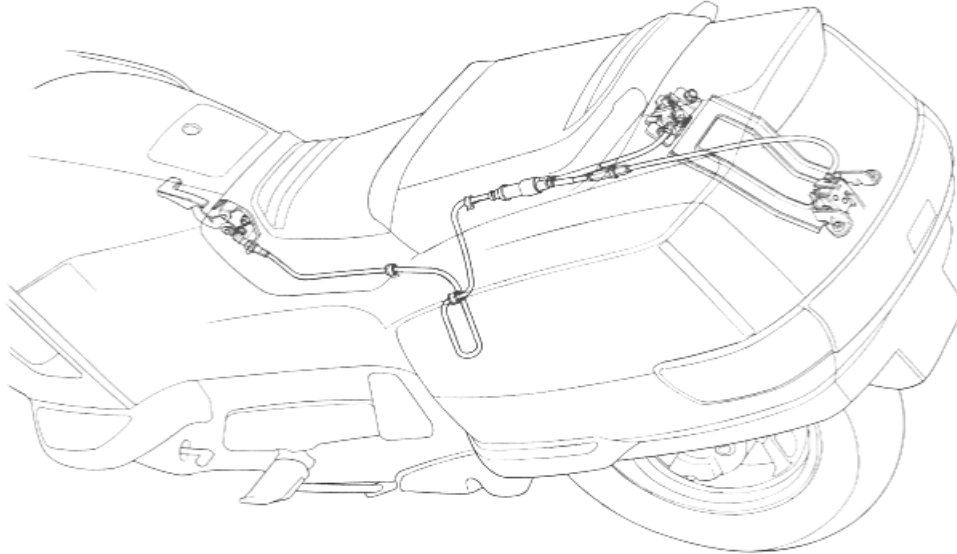

Adjustment

Remove the four socket head bolts and the passenger seat.

Open the trunk lid, remove the trunk rubber seal.  
Remove the ten (twelve-AFTER '89) self tapping screws.

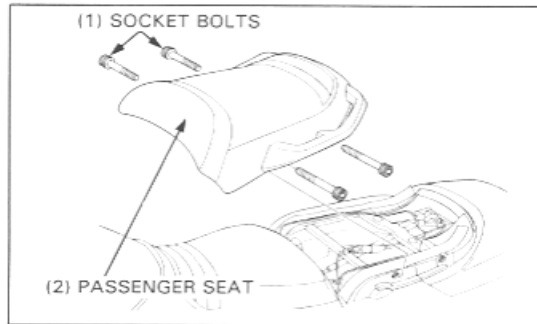

AFTER '89:

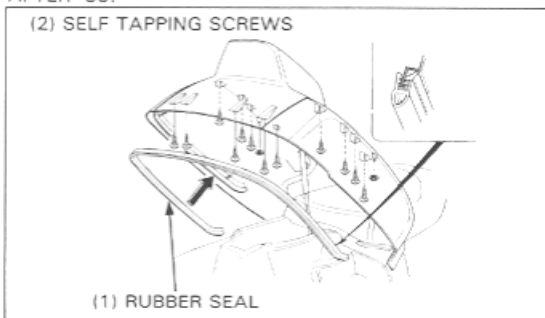

'89:

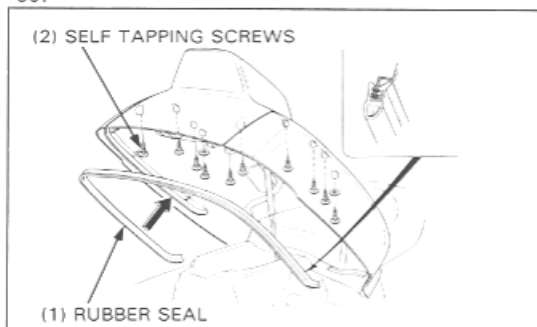

## Frame/Body Panels/Exhaust System

Remove the tail cowl.

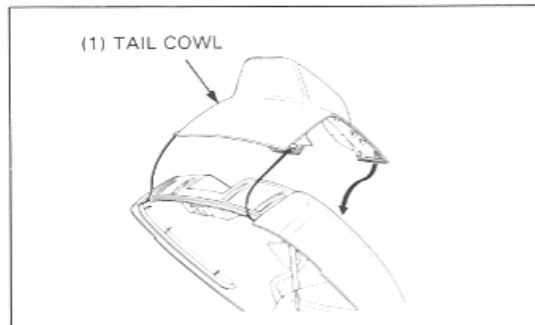

Close the trunk lid, operate the trunk lid release knob. Check the trunk lid release cable end and trunk lid lock operation.

If the upper lock cable does not allow the trunk lock to unlock, replace the release cable.

If the lower cable does not allow full stroke to the unlocked position, adjust the lower cable.

Adjust stroke by loosening the lock nut and turning the adjuster. Then tighten the lock nut.

Lubricate the release cable with the clean engine oil. Apply grease to the trunk lock.

'89:

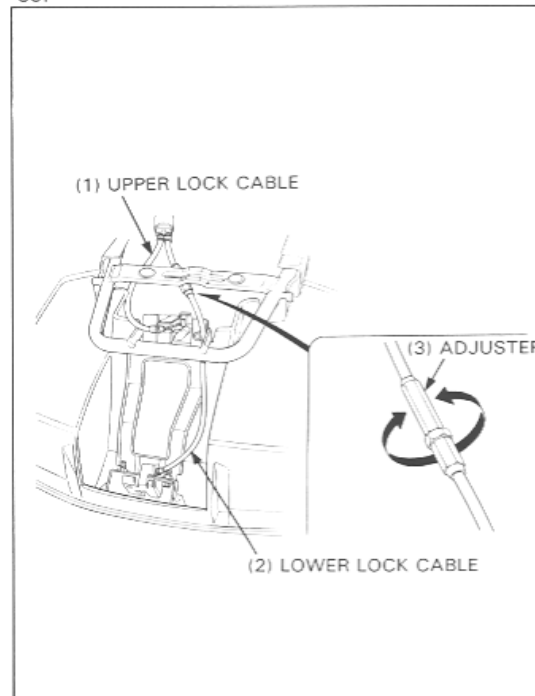

### Trunk Release Cable Replacement

Remove the front cable end from the opener (page 2-19).

Remove each cable end from the lock.

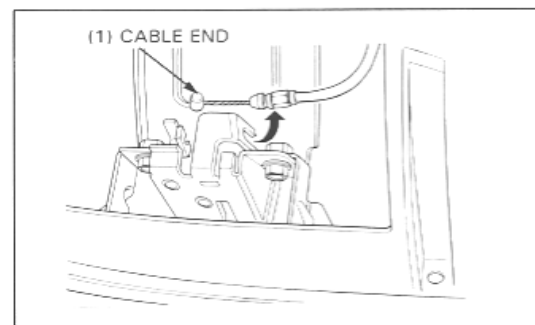

Remove the cable from the three clamps.

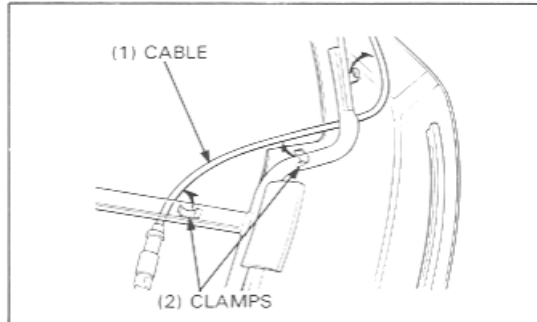

**Trunk Lock Replacement ('89)**

If the trunk lock does not operate smoothly, replace the trunk lock.

Remove the upper trunk release cable.  
Remove the two flange nuts and the upper trunk lock.

'89:

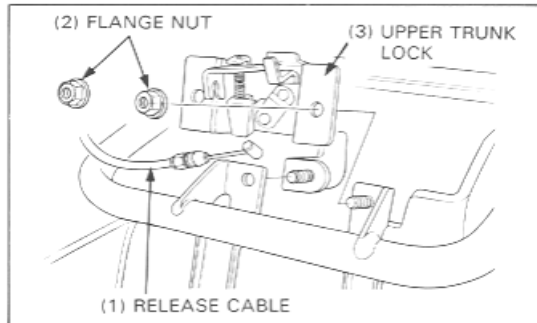

Remove the lower trunk release cable.  
Remove the four flange bolts and the lower trunk lock.

'89:

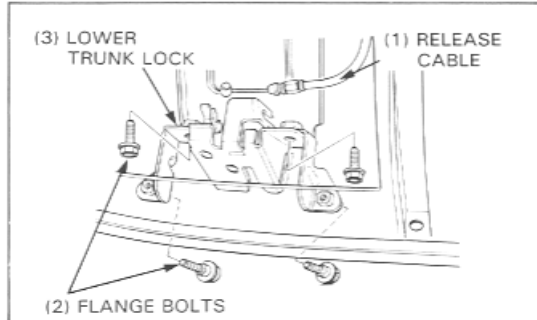

**Trunk Lock Replacement (AFTER '89)**

Disconnect the lower trunk release cable.  
Remove the two flange bolts and the lower trunk lock.

AFTER '89:

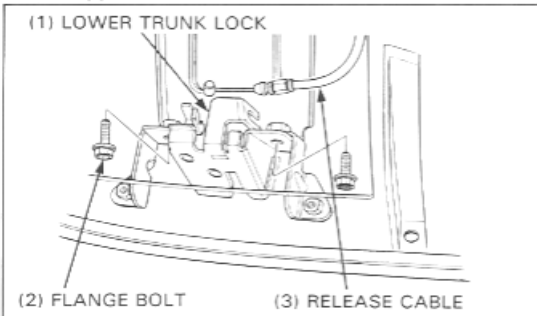

## Frame/Body Panels/Exhaust System

Open the trunk lid.  
Remove the five mounting bolts.

AFTER '89:

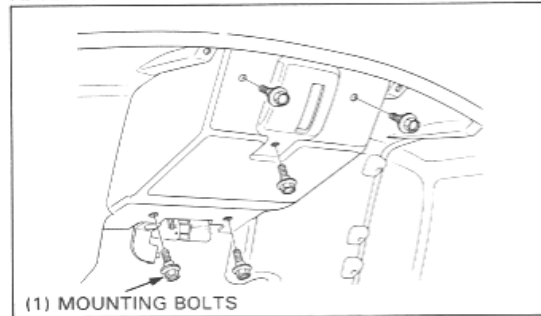

Remove the two mounting nuts and damper stay.  
Remove the lock holder plate and upper trunk lock.

AFTER '89:

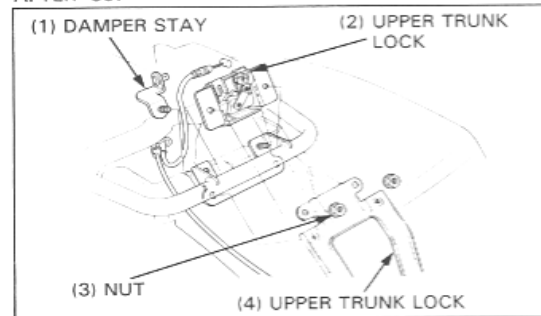

If the trunk does not close or does not close tightly, back off the adjusting rubbers or adjust the lower striker.  
Remove the rear fender (page 2-20).

Loosen the lower striker mounting bolts and adjust the striker.

Minor adjustments can be made at the special screw rubbers.

Open the trunk lid.  
Turn and adjust the rubbers so that the trunk lid closes securely.  
The trunk lid should open after pulling up the release lever once. You should not have to hold the lever up.

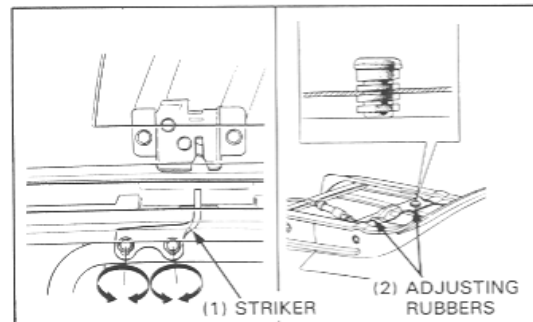

## Exhaust System Removal/Installation

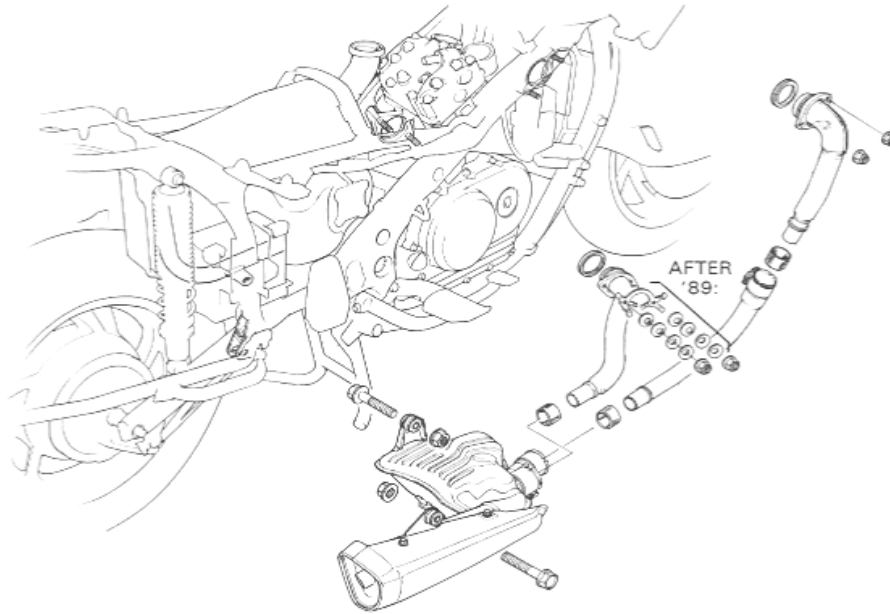

### Front Cylinder Exhaust Pipe Removal/Installation

**⚠ WARNING**

- Do not service the exhaust system while it is hot.

#### Front Exhaust Pipe A

Remove the right air duct/maintenance lid (page 2-4).  
Remove the front lower cowl (page 2-5).

Loosen the front exhaust pipe A to B joint band bolts.  
Remove the front exhaust pipe joint nut.

Release the exhaust pipe joint from the exhaust pipe B, then  
remove the exhaust pipe A under the frame.

Installation is in the reverse order of removal.

#### NOTE

- At installation, install the new gaskets onto the exhaust pipe A.
- Tighten the exhaust pipe joint nuts first, then the joint band bolts.

#### Torque:

Muffler joint band bolt: 22 N·m (2.2 kg-m, 16 ft-lb)  
Exhaust pipe joint nut: 22 N·m (2.2 kg-m, 16 ft-lb)

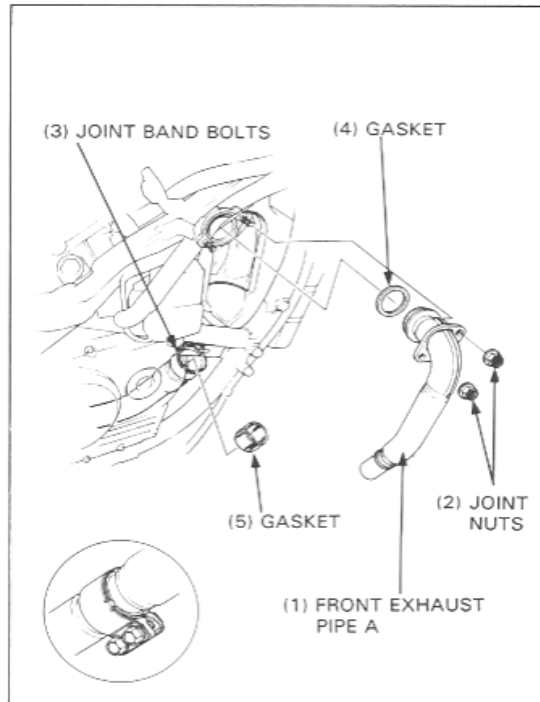

## Frame/Body Panels/Exhaust System

### Front Exhaust Pipe B

Loosen the joint band bolts.

Release the exhaust pipe B from the exhaust pipe A.

Then remove the exhaust pipe B from the muffler.

Installation is in the reverse order of removal.

#### NOTE

- At installation, install the new gaskets onto the front exhaust pipe and muffler joint.

#### Torque:

Muffler joint band bolt: 22 N·m (2.2 kg-m, 16 ft-lb)

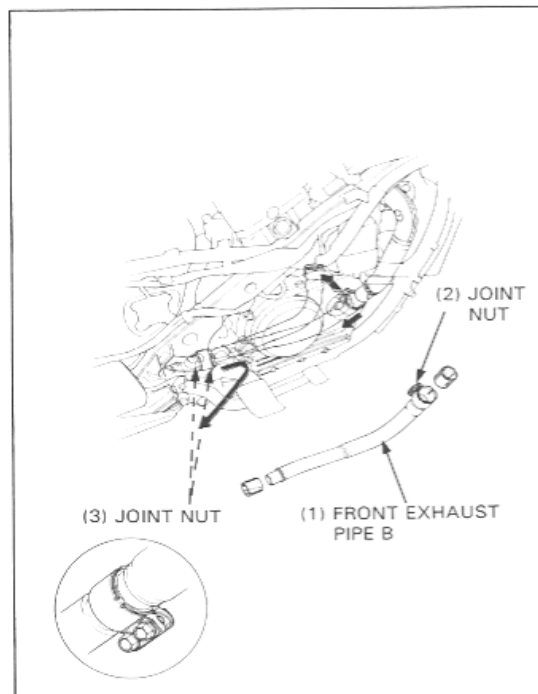

### Rear Cylinder Exhaust Pipe Removal/Installation

Remove the engine heat covers (page 7-2).

Remove the muffler.

'89:

Remove the exhaust pipe joint nuts, then remove the rear exhaust pipe from the frame.

AFTER '89:

Release the tabs of the tongued washer.

Remove the exhaust pipe joint nuts and washers, then remove the rear exhaust pipe out of the frame.

Installation is in the reverse order of removal.

#### NOTE

- At installation, install the new gaskets onto the rear exhaust pipe joint, then install it into the muffler.
- After installation of the exhaust pipe, set the new tongued washer and spring washers as shown (AFTER '89).
- Tighten the exhaust pipe joint nuts first, then the joint band bolts.

#### Torque:

Muffler joint band bolt: 22 N·m (2.2 kg-m, 16 ft-lb)

Exhaust pipe joint nut:

'89: 22 N·m (2.2 kg-m, 16 ft-lb)

AFTER '89: 18 N·m (1.8 kg-m, 13 ft-lb)

Muffler mounting bolt: 27 N·m (2.7 kg-m, 20 ft-lb)

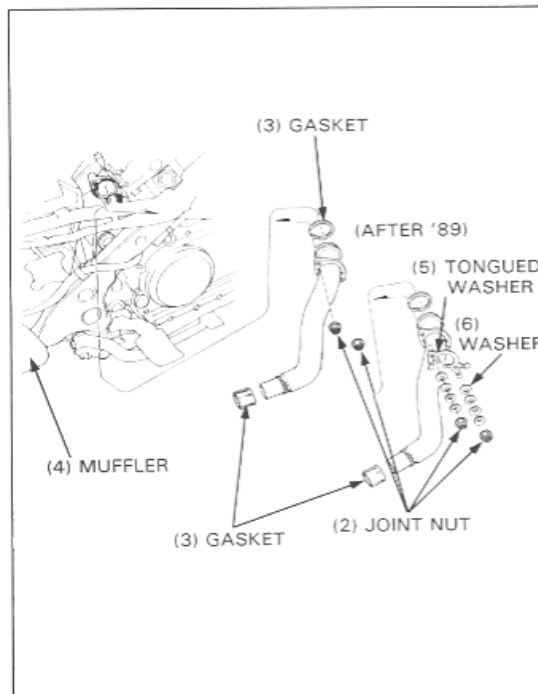

**Muffler Removal/Installation**

**Removal**

Remove the front exhaust pipe B.  
Loosen the rear exhaust pipe joint band bolts.

Remove the muffler mounting bolts.  
Slide back and release the rear exhaust pipe joints, then remove the muffler.

Remove the bolts and the muffler cover.

**Installation**

Install the new gaskets onto the exhaust pipes.

Install the muffler aligning the joints with the rear exhaust pipes.

**NOTE**

- Check that the gaskets are seated in their position as shown.

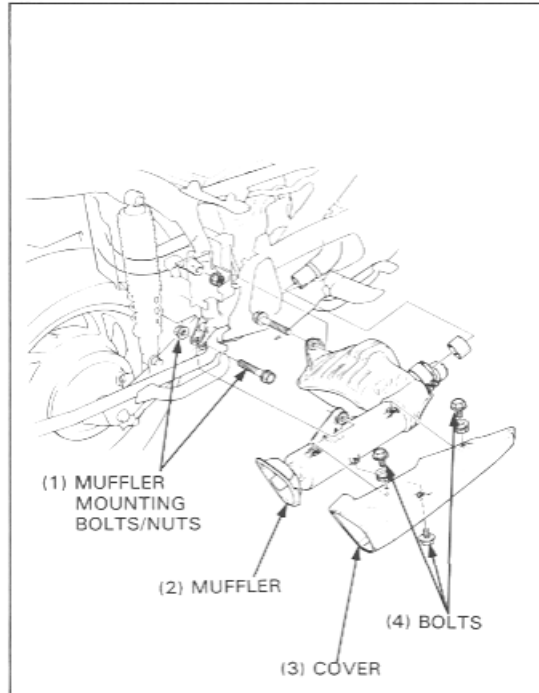

Install the muffler mounting bolts.

Check that the muffler joint gaskets are seated. First tighten the muffler mounting bolts, then the joint band bolts.

**Torque:**

- Muffler mounting bolt: 27 N·m (2.7 kg·m, 20 ft·lb)
- Muffler joint band bolt: 22 N·m (2.2 kg·m, 16 ft·lb)

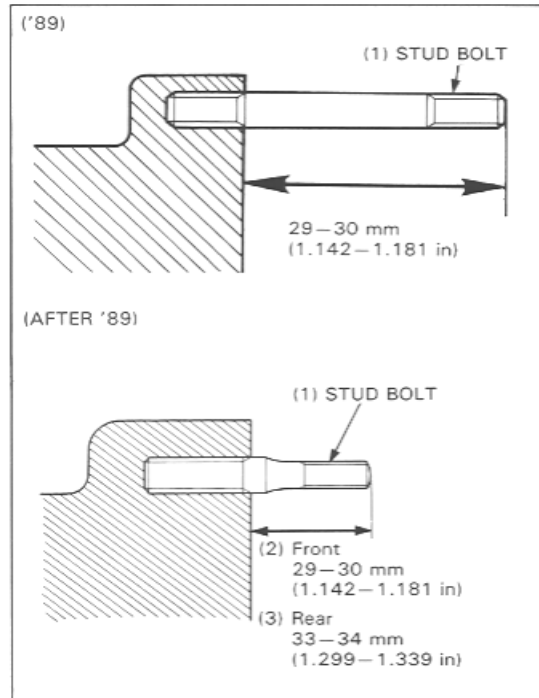

**Exhaust Pipe Joint Stud Bolt Replacement**

If you replace the stud bolt, remove the stud bolt from the cylinder head.

Install the new stud bolt.

After installing, be sure to measure the distance from the top of each stud to the cylinder head surface as shown.

## Fuel Tank Removal

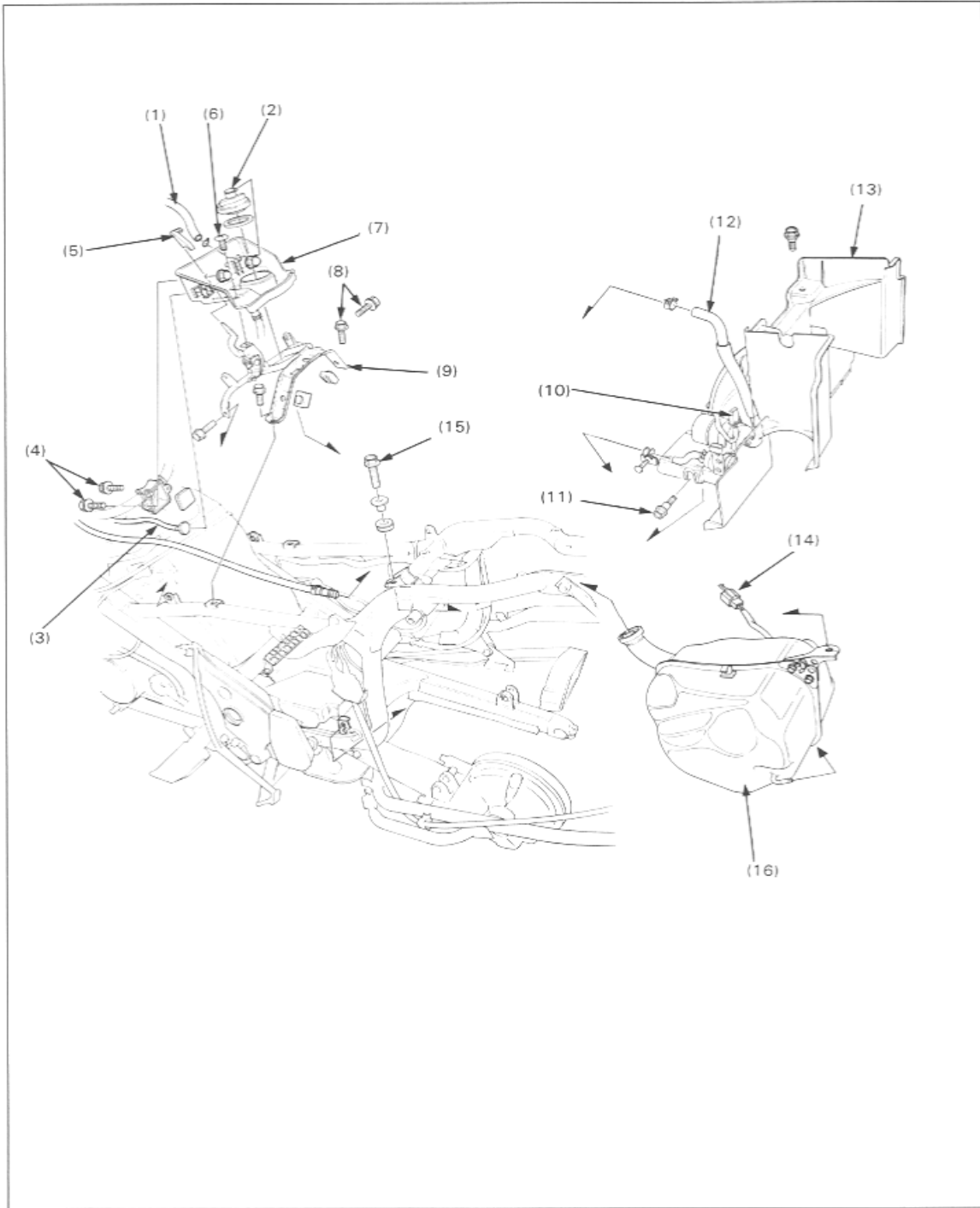

**⚠ WARNING**

- Gasoline is extremely flammable and is explosive under certain conditions.

NOTE

- Before removal, drain the gasoline from the fuel tank (page 18-22).

**Requisite Service**

- Trunk assembly removal (page 2-19)
- Battery removal (page 15-4)
- Shock absorber removal (page 13-6)
- Lower cover removal (page 2-6)

Procedure	Q'ty	Remarks
<b>Removal Order</b>		
(1) Fuel vapor tube	1	California model only.
(2) Fuel fill cap	1	
(3) Throttle stop screw	1	
(4) Sub air cleaner housing mounting bolt/nut	2/2	
(5) Trunk opener knob	1	
(6) Self tapping screw	1	
(7) Fuel lid inner case	1	
(8) Top shelter frame mounting bolt	4	
(9) Top shelter frame	1	
(10) Fuel pump wire connector	1	
(11) Rear fender B mounting bolt	2	
(12) Fuel tube	2	
(13) Rear fender B	1	
(14) Fuel level sensor wire connector	1	
(15) Fuel tank mounting bolt	1	
(16) Fuel tank assembly	1	Slide back and remove the tank from the frame.

## Fuel Tank Installation

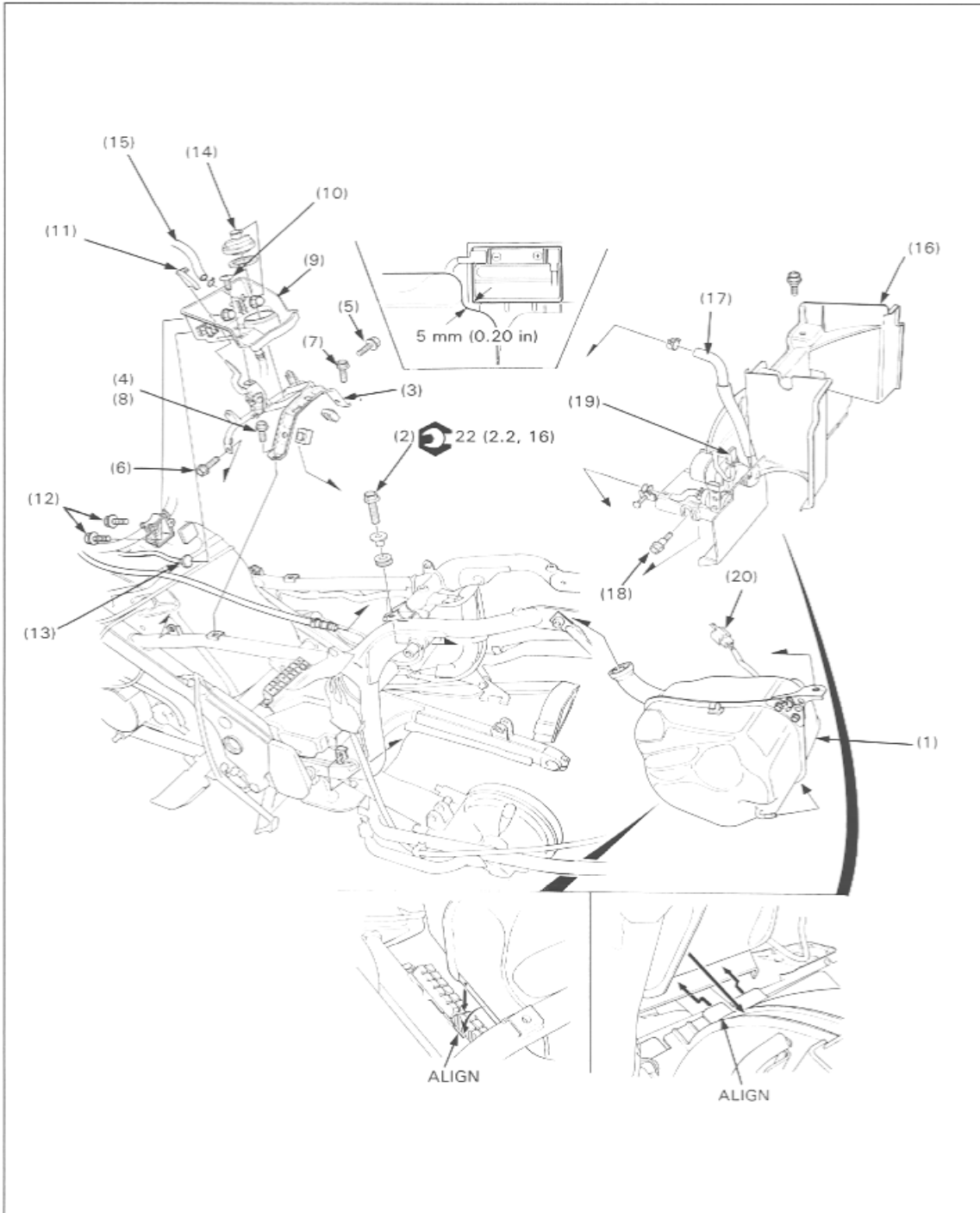

NOTE

- When installing, check the following items:
  - Battery to fuel tank clearance is over 5 mm (0.20 in).
  - Fuel tank flange alignment with the fuel tank lower mounting rubber groove.
  - Fuel tank flange alignment with the rear fender B groove.

Requisite Service

- Trunk assembly installation (page 2-19)
- Battery installation (page 15-4)
- Shock absorber installation (page 13-6)
- Lower cover installation (page 2-6)

Procedure	Q'ty	Remarks
<b>Installation Order</b>		
(1) Fuel tank assembly	1	
(2) Fuel tank mounting bolt	1	
(3) Top shelter frame	1	NOTE
(4) Top shelter frame mounting bolt		• Apply soap water to the fuel tank mounting rubber face.
(5) (rear/left)	1	Only loosely install.
(6) (front/right)	1	Tighten them.
(7) (front/left)	1	
(8) (rear/right)	1	
(9) (rear/left)	1	
(9) Fuel lid inner case	1	
(10) Tapping screw	1	
(11) Trunk opener knob	1	
(12) Sub air cleaner housing mounting bolt/nut	2/2	
(13) Throttle stop screw	1	
(14) Fuel fill cap	1	
(15) Fuel vapor tube	1	California model only.
(16) Rear fender B	1	NOTE
(17) Fuel tube	2	• Align the tabs with the fuel tank lower heat cover.
(18) Rear fender B mounting bolt	2	
(19) Fuel pump wire connector	1	
(20) Fuel level sensor wire connector	1	

---

## 3. Maintenance



Service Information	3-1	Carburetor Synchronization	3-6
Service Access Guide	3-2	Carburetor Idle Speed	3-7
Maintenance Schedule	3-4	Radiator Coolant	3-7
Carburetor Choke	3-5	Headlight Aim	3-8
Air Cleaner	3-5	Side Stand	3-8
Spark Plug	3-5		

**3**

### Service Information

- Refer to Common Service Manual for service procedures on items not included in this manual.
- Refer to the specifications (Section 1) for maintenance service data.

## Service Access Guide

- The following shows the locations of the parts that must be removed for the maintenance items listed below. Refer to the Common Service Manual for items not included in this manual.
- Refer to section 2 (Frame/body panels/exhaust system), for the parts that must be removed for service.  
For example: AIR CLEANER (Contamination, clogging, replacement): Parts
  - Side cover  The parts that must be removed for service.
  - Fuel tank 

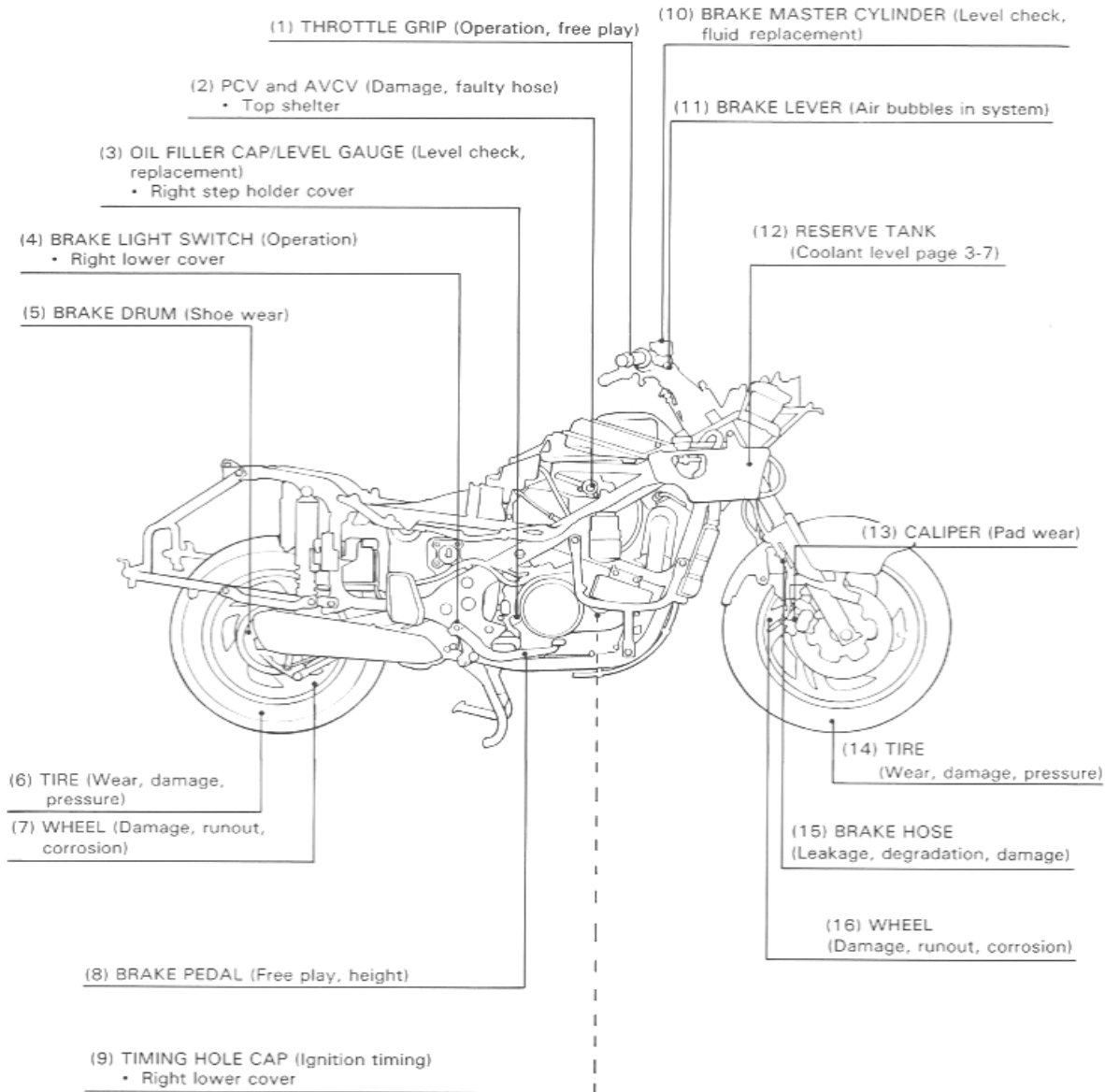

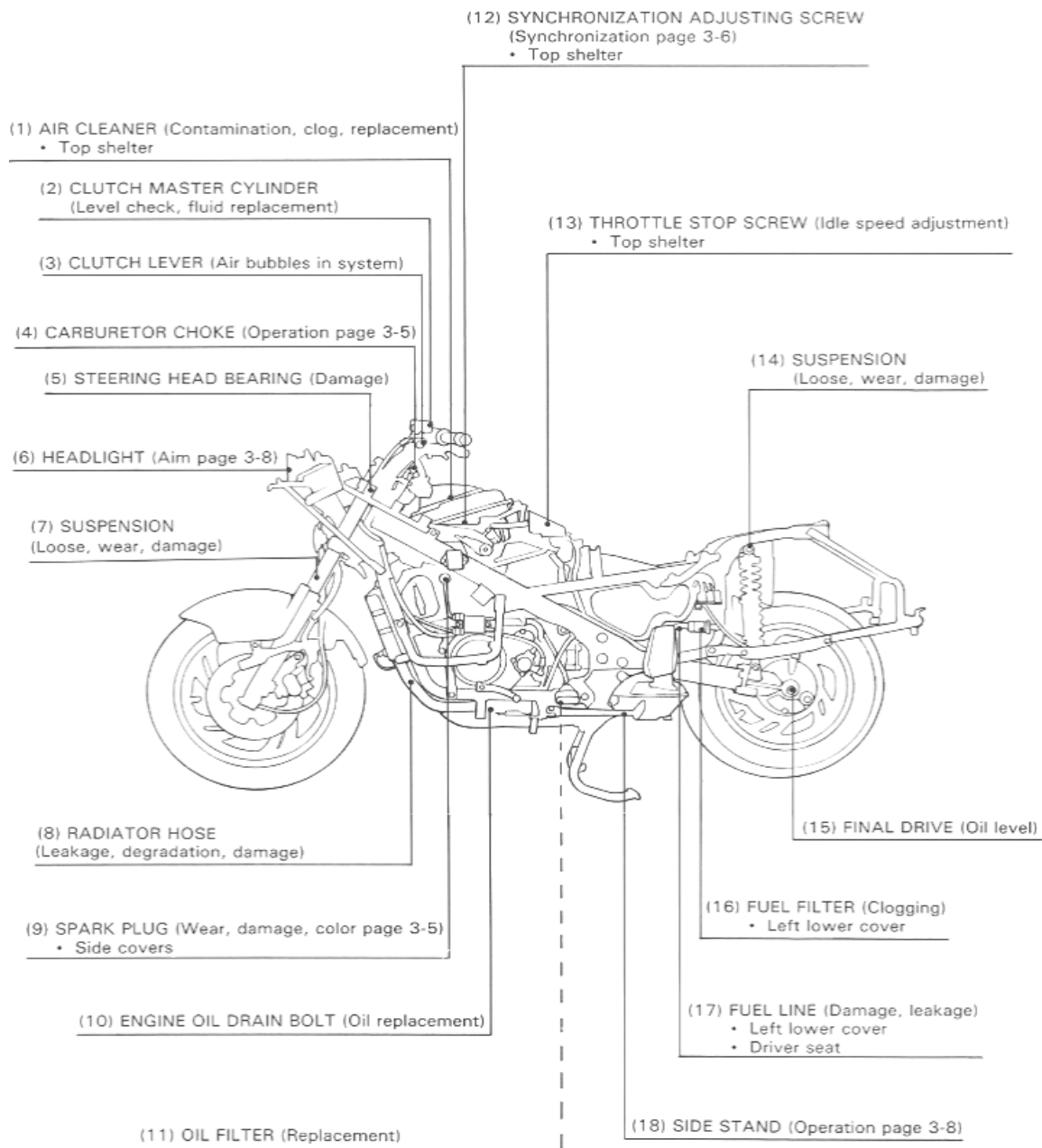

## Maintenance Schedule

Perform the PRE-RIDE INSPECTION in the Owner's Manual at each scheduled maintenance period.

I: Inspect and clean, Adjust, Lubricate, or Replace if necessary.

R: Replace, C: Clean, L: Lubricate, A: Adjust

The following items require some mechanical knowledge. Certain items (particularly those marked \* and \*\*) may require more technical information and tools. Consult their authorized Honda dealer.

Item	Frequency	Note ↓	Odometer Reading (Note 1)								Refer to page	
			x 1,000 mi	0.6	4	8	12	16	20	24		
			x 100 km	10	64	128	192	256	320	384		
EMISSION RELATED ITEMS	* Fuel Line					I			I		I	Note 5
	* Throttle Operation					I			I		I	Note 5
	* Carburetor Choke					I			I		I	3-5
	Air Cleaner	(Note 2)						R			R	3-5
	Spark Plug				I	R	I	R	I	R	R	3-5
	Engine Oil			R		R		R		R	R	Note 5
	Engine Oil Filter			R		R		R		R	R	Note 5
	* Carburetor Synchronization			I		I		I		I	I	3-6
	* Carburetor Idle Speed			I	I	I	I	I	I	I	I	3-7
	Radiator Coolant	(Note 4)				I		I		R	R	3-7
	* Cooling System					I		I		I	I	Note 5
	* Evaporative Emission Control System	(Note 3)					I			I	I	Note 3, 5
NON-EMISSION RELATED ITEMS	Final Drive Oil					I		I		R	R	Note 5
	Brake Fluid	(Note 4)			I	I	R	I	I	I	R	Note 5
	Brake Shoe/Pad Wear				I	I	I	I	I	I	I	Note 5
	Brake System			I		I		I		I	I	Note 5
	* Brake Light Switch					I		I		I	I	Note 5
	* Headlight Aim					I		I		I	I	3-8
	Clutch System					I		I		I	I	Note 5
	Clutch Fluid	(Note 4)			I	I	R	I	I	R	R	Note 5
	Side Stand					I		I		I	I	3-8
	* Suspension					I		I		I	I	Note 5
	* Nuts, Bolts, Fasteners			I		I		I		I	I	Note 5
	** Wheels/Tires					I		I		I	I	Note 5
** Steering Head Bearings			I		I		I		I	I	Note 5	

\* Should be serviced by an authorized Honda dealer, unless the owner has the proper tools and service data and is mechanically qualified.

\*\* In the interest of safety, we recommended these items be serviced only by an authorized Honda dealer.

Notes: 1. At higher odometer readings, repeat at the frequency interval established here.

2. Service more frequently when riding in unusually wet or dusty areas.

3. California model only.

4. Replace every 2 years, or at indicated odometer interval, whichever comes first. Replacement requires mechanical skill.

5. Refer to Common Service Manual.

## Carburetor Choke

This model's choke system uses a fuel enriching circuit controlled by a starting enrichment valve. The starting enrichment valve opens the enriching circuit via a cable when the choke knob near the ignition switch is pulled up. Check for smooth choke knob operation. Lubricate the choke cable if the operation is not smooth.

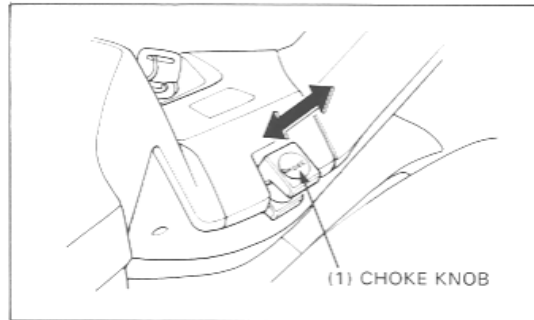

## Air Cleaner

Remove the top shelter (Section 2).

Remove the screws and the air cleaner housing cover. Remove the element from the air cleaner housing. Replace the element in accordance with the maintenance schedule or any time it is excessively dirty or damaged.

Install the element in the reverse order of removal.

### NOTE

- Be sure the UP mark on the element is facing up.

Torque: Air cleaner housing cover screw:  
1.8 N·m (0.18 kg·m, 1.3 ft·lb)

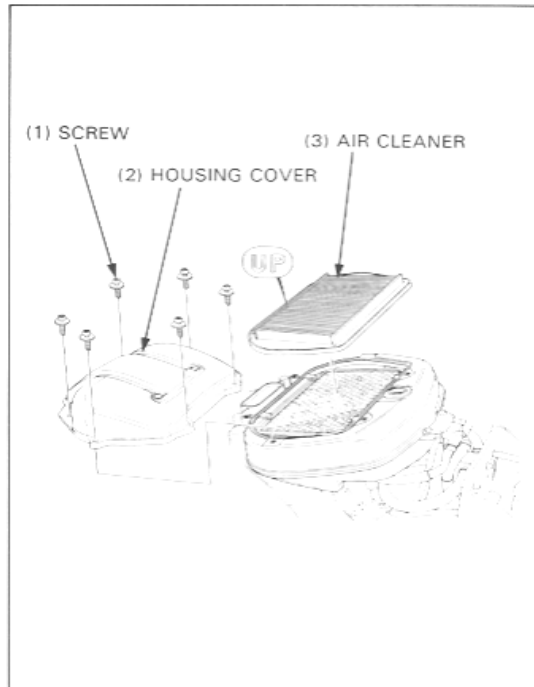

## Spark Plug

### ⚠ WARNING

- Do not touch the exhaust pipe while it is hot.

Remove the side covers (Section 2). The spark plug wrench is included in the tool kit. Disconnect the spark plug caps and clean away any dirt from around the spark plug bases. Remove and discard the spark plugs.

### NOTE

- Front plug: Use spark plug wrench with the extension on right side for spark plug removal and installation.
- Rear plug: Use spark plug wrench without extension on right side for spark plug removal and installation.

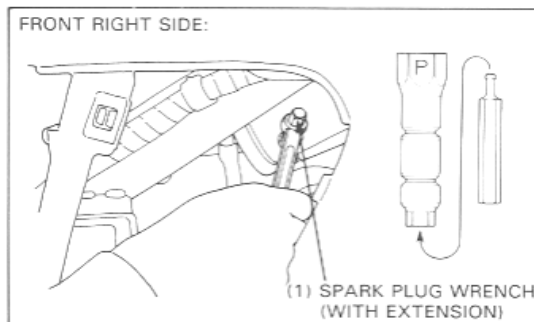

## Maintenance

Recommended spark plug (see section 1: Specifications).  
Adjust the gap if necessary.  
Install the spark plugs.

Torque: 14 N·m (1.4 kg·m, 10 ft·lb)

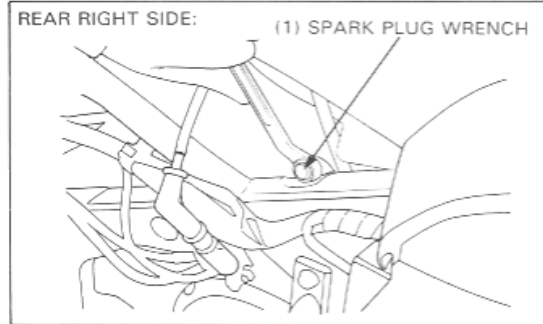

## Carburetor Synchronization

### Vacuum Plug Location

#### NOTE

- Refer to section 2 of Common Service Manual for carburetor synchronization procedure.
- Synchronize the carburetors with the engine at normal operating temperature, the transmission in neutral and the motorcycle on its center stand.

#### California Model Only:

Remove the top shelter (Section 2).  
Remove the plug and fuel auto valve tube from the carburetor.  
Install the vacuum gauge adapter tube with each carburetor joint.

#### Except California Model:

Remove the top shelter (Section 2).  
Remove the plug and fuel auto valve tube from the carburetor.

Install the vacuum gauge adapter tube with each carburetor joint.

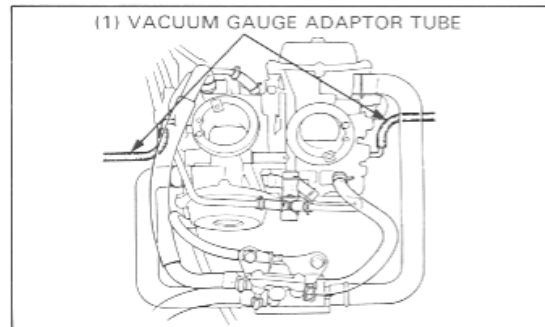
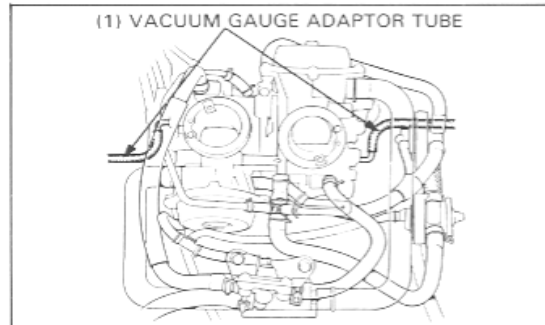

Disconnect the vacuum tube from the intake manifold of the rear carburetor, draw vacuum and pinch the tube with a clip as shown.



Vacuum pump with gauge

ST-AH-260-MC7

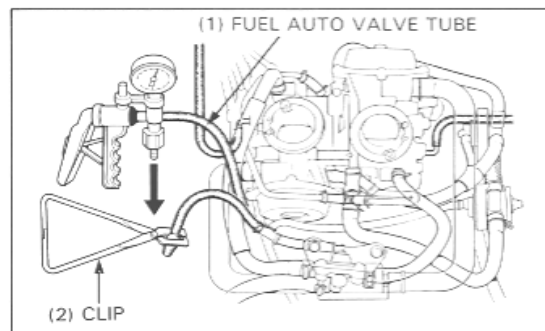

Turn the synchronization adjusting screw, adjust the synchronization.

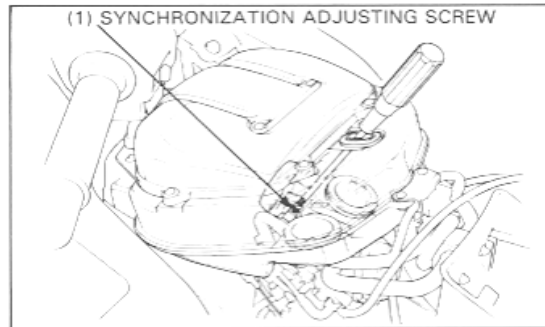

## Carburetor Idle Speed

### NOTE

- Inspect and adjust idle speed after all other engine adjustments are within specification.
- Engine must be warm for accurate adjustment. Ten minutes of stop-and-go riding is sufficient.

Open the top shelter lid using the ignition key.

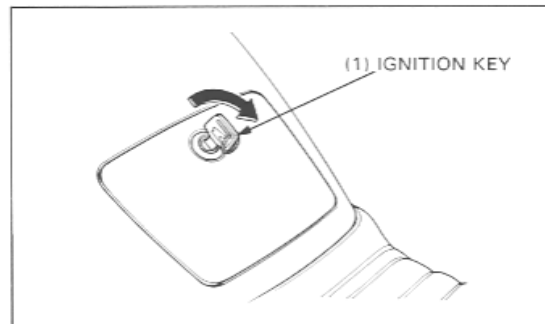

Warm up the engine.  
Place the motorcycle on its center stand and shift the transmission into neutral.  
Check the idle speed.  
Adjust by turning the throttle stop screw if necessary.

Idle Speed: 1,200 ± 100 rpm

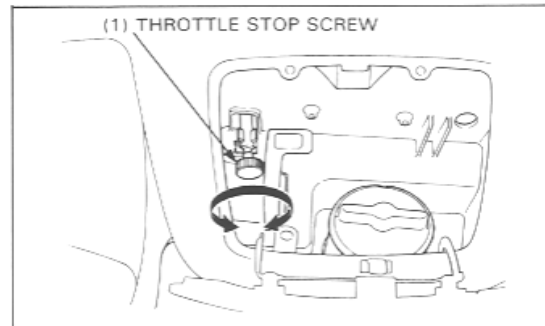

## Radiator Coolant

Check the coolant level of the reserve tank with the engine running at normal operating temperature.  
The level should be between the "UPPER" and "LOWER" level line.

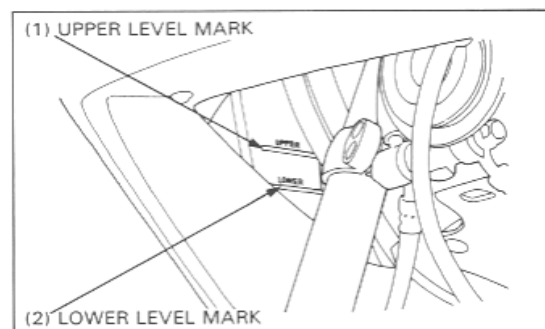

## Maintenance

If necessary add the coolant following this procedure.

- Open the reserve tank lid.
- Remove the filler cap and fill to the "UPPER" level line with a 50/50 mixture of distilled water and anti-freeze.

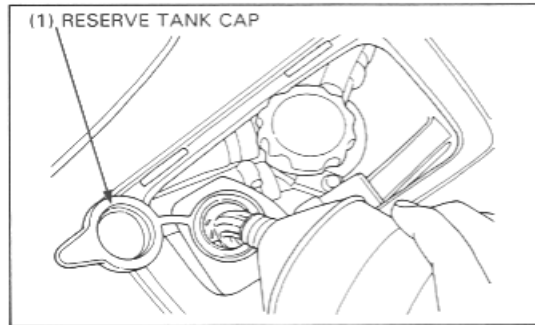

## Headlight Aim

### ⚠ WARNING

- An improperly adjusted headlight may blind on-coming drivers, or it may fail to light the road for a safe distance.

Place the motorcycle on a level surface.

Adjust the headlight beam using the cross head screw driver as shown.

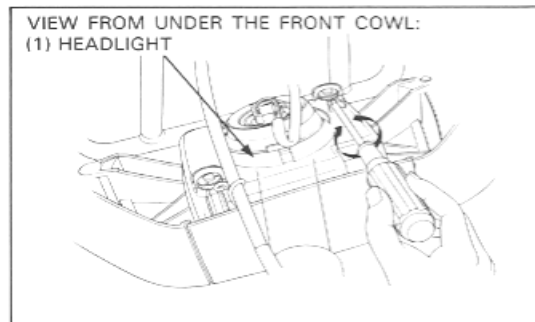

Adjust the headlight beam vertically or horizontally with the special adjustment screws as shown.

Adjustment	Vertical	Horizontal
Turn clockwise	Down	Right
Turn counterclockwise	Up	Left

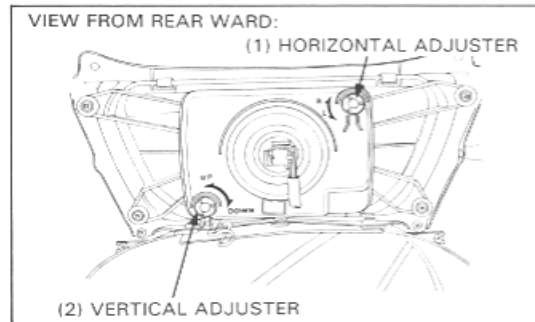

## Side Stand

Check the side stand ignition cut-off system:

- Place the motorcycle on its center stand and raise the side stand.
- Start the engine with the transmission in neutral, then shift the transmission into gear with the clutch lever pulled in.
- Move the side stand down fully.
- The engine should stop as the side stand is lowered.

If there is a problem with the system, check the side stand switch (Section 18).

Check the side stand switch mounting bolts for looseness.

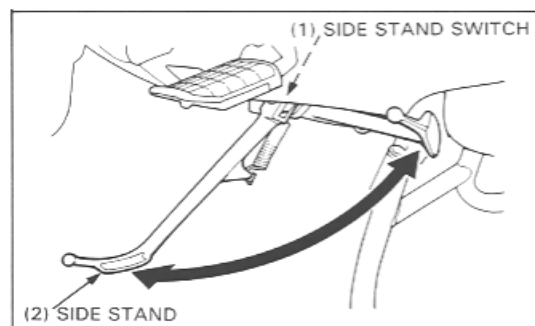



---

## 4. Lubrication System

Service Information	4-1	Oil Pump Removal/Installation	4-3
Troubleshooting	4-1	Oil Pump Disassembly/Assembly	4-4
Lubrication System Diagram	4-2		

### Service Information

## 4

#### ▲ WARNING

- If the engine must be running to do some work, make sure the area is well ventilated. Never run the engine in an enclosed area. The exhaust contains poisonous carbon monoxide gas that can cause loss of consciousness and may lead to death. Run the engine in an open area or with an exhaust evacuation system in an enclosed area.
- Used engine oil may cause skin cancer if repeatedly left in contact with the skin for prolonged periods. Although this is unlikely unless you handle used oil on a daily basis, it is still advisable to thoroughly wash your hands with soap and water as soon as possible after handling used oil.

- The service procedures in this section can be performed with the engine oil drain.
- When removing and installing the oil pump use care not to allow dust or dirt to enter the engine.
- If any portion of the oil pump is worn beyond the specified service limits, replace the oil pump as an assembly.
- After the oil pump has been installed, check that there are no oil leaks and that oil pressure is correct.
- For oil pressure check, refer to section 4 of the Common Service Manual; for the switch location, see page 18-2 of this manual.
- For oil pressure warning light inspection, refer to section 25 of the Common Service Manual.

### Troubleshooting

#### Oil Level Low

- Oil consumption.
- External oil leak.
- Worn piston ring or incorrect piston ring installation.
- Worn valve guide or seal.

#### Low or No Oil Pressure

- Clogged oil orifice.
- Incorrect oil being used.

#### Oil Contamination

- From coolant mixing with oil.
  - Faulty water pump mechanical seal.
  - Faulty head gasket.
  - Water leak in crankcase.

#### No Oil Pressure

- Oil level too low.
- Oil pump drive chain or drive sprocket broken.
- Oil pump damaged (pump shaft).
- Internal oil leaks.

#### Low Oil Pressure

- Pressure relief valve stuck open.
- Clogged oil filter screen.
- Oil pump worn or damaged.
- Internal oil leak.
- Incorrect oil being used.
- Low oil level.

#### High Oil Pressure

- Pressure relief valve stuck open.
- Plugged oil filter, gallery, or metering orifice.
- Incorrect oil being used.

## Lubrication System Diagram

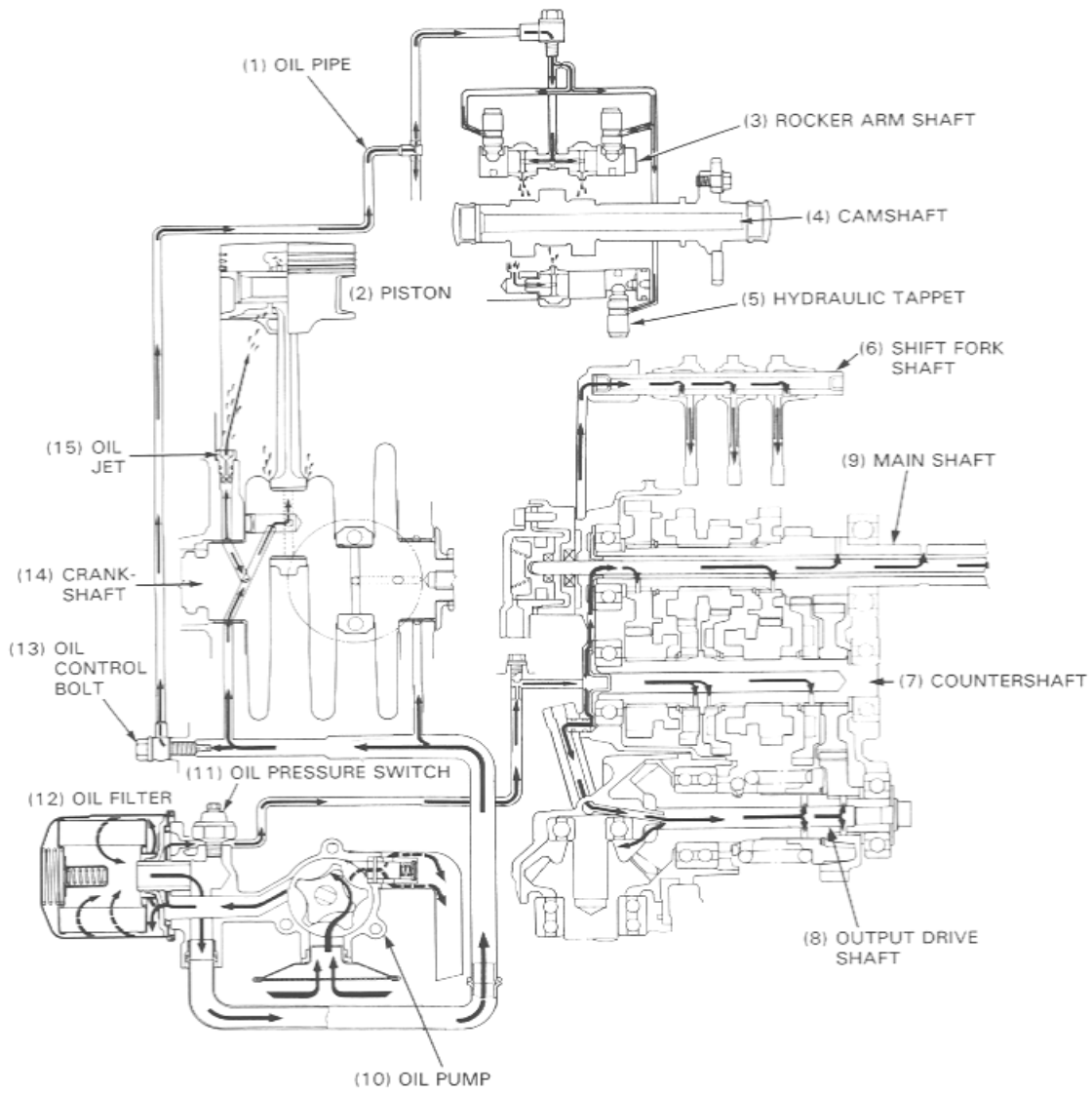

## Oil Pump Removal/Installation

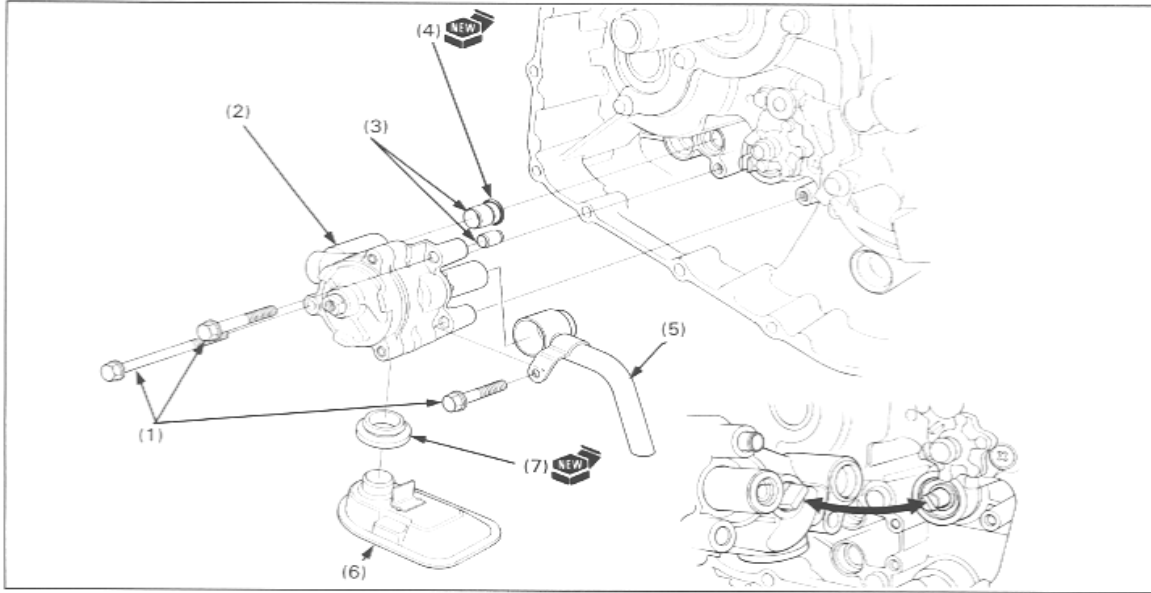

**NOTE**

- Use care not to allow dust or dirt to enter the engine.
- After installation, check that there are no oil leaks and that oil pressure is correct.

**Requisite Service**

- Clutch removal/installation (page 9-6)
- Gearshift linkage removal/installation (page 9-10)

Procedure	Q'ty	Remarks
<b>Removal Order</b>		Installation is in the reverse order of removal.
(1) Oil pump mounting bolt	3	<b>NOTE</b> • At installation, position the oil pump shaft lug in the water pump shaft groove.
(2) Oil pump assembly	1	
(3) Dowel pin	2	
(4) O-ring	1	
(5) Oil suction pipe	1	
(6) Oil strainer	1	
(7) O-ring	1	

## Oil Pump Disassembly/Assembly

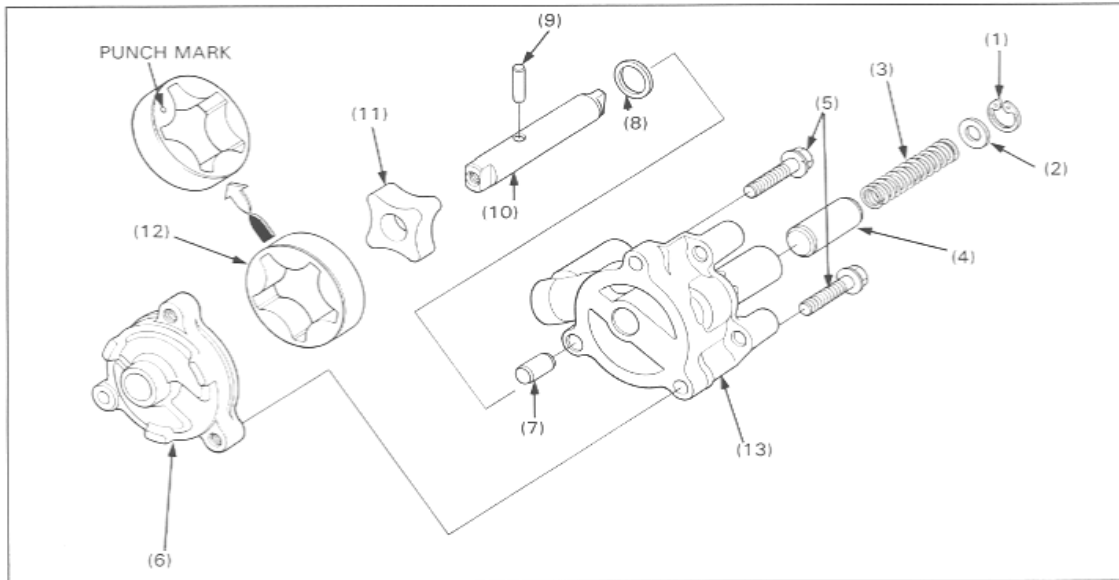

**NOTE**

- If any portion of the oil pump is worn beyond the specified service limits, replace the oil pump as an assembly.
- Before installing them, clean all removed parts thoroughly with clean engine oil.
- Refer to section 4 of the Common Service Manual for inspection information.
- Refer to page 1-6 for specification.

**Requisite Service**

- Oil pump removal/installation (page 4-3)

Procedure	Q'ty	Remarks
<b>Disassembly Order</b>		Assembly is in the reverse order of disassembly.
(1) Snap ring	1	
(2) Washer	1	
(3) Spring	1	
(4) Piston	1	
(5) Bolt	2	After installation, check that the rotor shaft turns freely.
(6) Oil pump body cover	1	
(7) Dowel pin	1	
(8) Spacer	1	Install into the inner rotor groove.
(9) Drive pin	1	Install in the rotor shaft hole.
(10) Rotor shaft	1	<b>NOTE</b> • Align the slots in the inner rotor with the drive pin.
(11) Inner rotor	1	
(12) Outer rotor	1	Install with its punch mark facing the pump body.
(13) Oil pump body	1	

---

## 5. Fuel System

Service Information	5-1	Carburetor Separation/Combination	5-7
Troubleshooting	5-2	Carburetor Disassembly/Assembly	5-8
Air Cleaner Housing Removal/Installation	5-3	Pilot Screw Adjustment (U.S.A. Only)	5-10
Carburetor Removal/Installation	5-4	High Altitude Adjustment (U.S.A. Only)	5-11
Carburetor Vacuum Tube Routing	5-6	Carburetor Draining	5-12

**5**

### Service Information

**▲ WARNING**

- Gasoline is extremely flammable and is explosive under certain conditions.
  - Bending or twisting the control cables will impair smooth operation and could cause the cables to stick or bind, resulting in loss of vehicle control.
- Work in a well ventilated area. Smoking or allowing flames or sparks in the work area or where gasoline is stored can cause a fire or explosion.

**CAUTION**

- Be sure to remove the diaphragms before cleaning air and fuel passages with compressed air. The diaphragms might be damaged.
- Refer to section 2 for fuel tank removal and installation.
- Refer to section 18 for fuel pump inspection, removal and installation.
- When disassembling fuel system parts, note the locations of the O-rings. Replace them with new ones on reassembly.
- Before disassembling the carburetor, place the suitable container under the carburetor drain hose, then loosen the drain bolt and drain the carburetor (page 5-12).
- After removing the carburetor, wrap the intake port of the engine with a shop towel or cover it with piece of tape to prevent any foreign material from dropping into the engine.

**NOTE**

- If the vehicle is to be stored for more than one month, drain the float bowls (page 5-12). Fuel left in the float bowls may cause clogged jets resulting in hard starting or poor driveability.
- **California Model Only:**  
All hoses used in the evaporative emission control system are numbered for identification. When connecting one of these hoses, compare the hose number with the Vacuum Hose Routing Diagram Label, page 1-30, and carburetor tubes routing, page 5-6.

---

**5-1**

## Troubleshooting

### Engine Won't Start

- Too much fuel getting to the engine
  - Air cleaner clogged
  - Flooded carburetor
- Intake air leak
- Fuel contaminated/deteriorated
- Starting enrichment circuit clogged
- No fuel to carburetor
  - Fuel strainer clogged
  - Fuel tube clogged
  - Fuel valve stuck
  - Float level misadjusted
  - Fuel tank breather tube clogged
  - Fuel pump malfunction

### Lean Mixture

- Fuel jets clogged
- Float valve faulty
- Float level too low
- Fuel line restricted
- Carburetor air vent tube clogged
- Intake air leak
- Throttle valve faulty
- Vacuum piston faulty
- Fuel pump malfunction

### Rich Mixture

- Starting enrichment valve in ON position
- Float valve faulty
- Float level too high
- Air jets clogged
- Air cleaner contaminated
- Flooded carburetor

### Engine Stall, Hard to Start, Rough Idling

- Fuel line restricted
- Ignition malfunction
- Fuel mixture too lean/rich
- Fuel contaminated/deteriorated
- Intake air leak
- Idle speed misadjusted
- Float level misadjusted
- Fuel tank breather tube clogged
- Fuel pump malfunction
- Pilot screw misadjusted
- Starting enrichment circuit clogged
- Evaporative emission carburetor air vent control valve faulty
- Hoses of the emission control system faulty
- Evaporative emission purge control valve faulty

### Afterburn When Engine Braking is Used

- Lean mixture in slow circuit
- Air cut-off valve malfunction
- Hoses of evaporative emission control system faulty

### Afterfiring or Misfiring during Acceleration

- Ignition system faulty
- Fuel mixture too lean

### Poor Performance (Driveability) and Poor Fuel Economy

- Fuel system clogged
- Ignition malfunction
- Faulty evaporative emission carburetor air vent control valve
- Damaged/misconnected evaporative emission control system hoses

## Air Cleaner Housing Removal/Installation

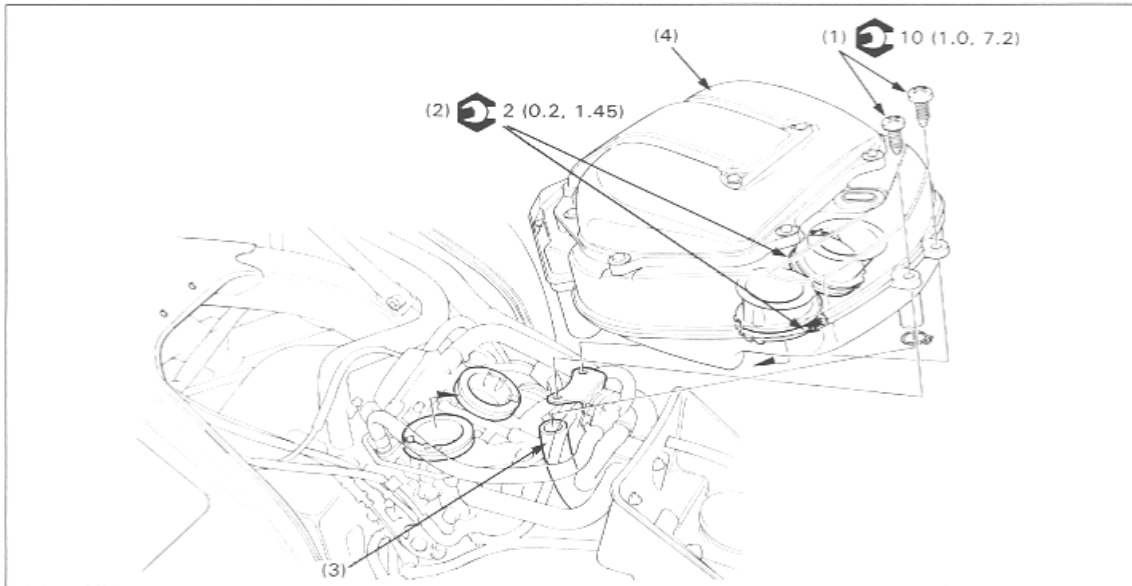

### Requisite Service

- Top shelter removal/installation (Section 2)

Procedure	Q'ty	Remarks
<b>Removal Order</b>		Installation is in the reverse order of removal.
(1) Air cleaner housing mounting self tapping screw	2	
(2) Connecting tube band screw	2	Only loosen.
(3) Breather tube	3	
(4) Air cleaner housing assembly	4	<b>NOTE</b> • At installation, install the air cleaner housing tab into the frame.

## Carburetor Removal/Installation

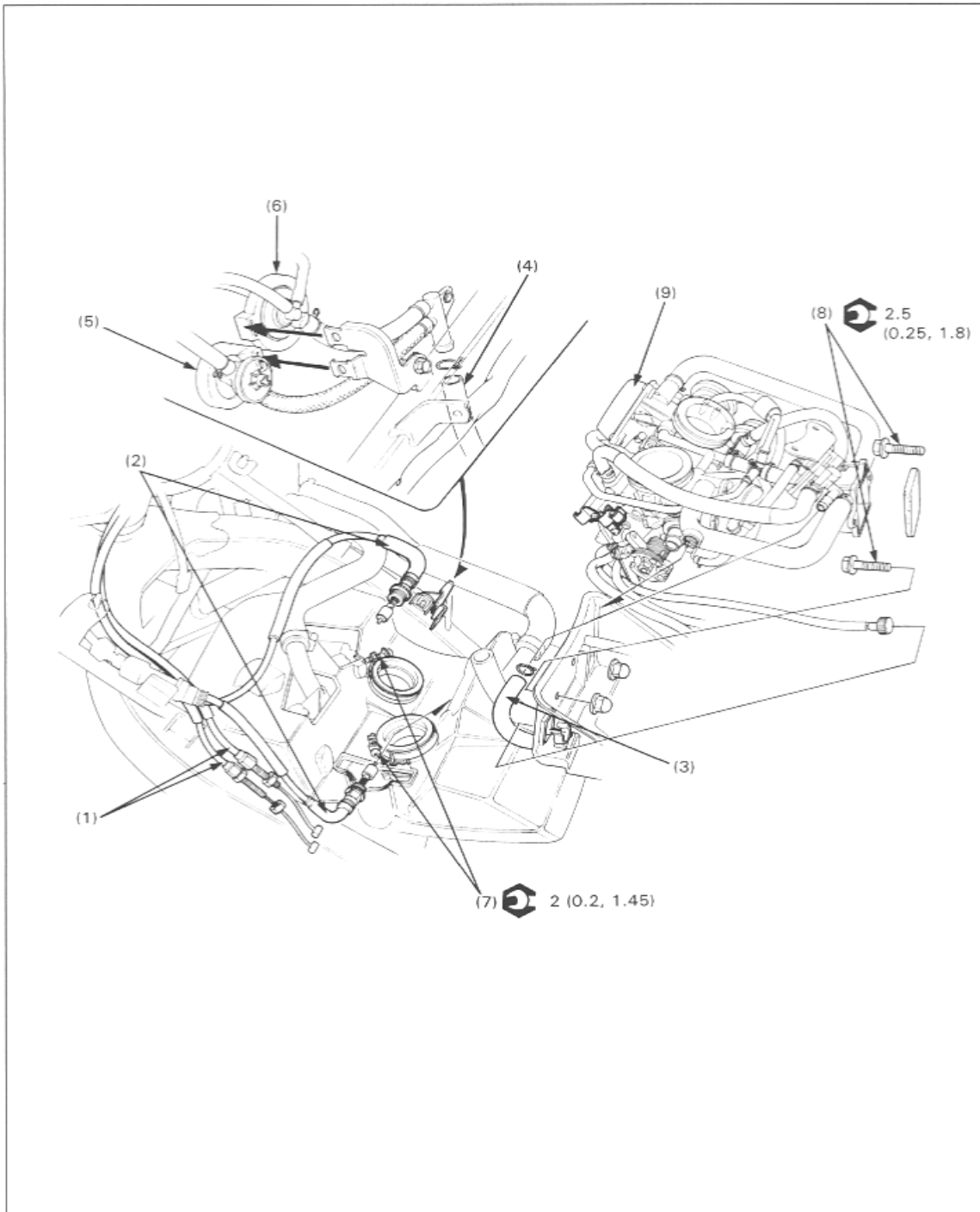

**⚠ WARNING**

• Gasoline is extremely flammable and is explosive under certain conditions.

- Work in a well ventilated area. Smoking or allowing flames or sparks in the work area or where gasoline is stored can cause a fire or explosion.

**NOTE**

• Vacuum hoses routing and fuel valve location are shown on page 5-6.

**Requisite Service**

- Air cleaner housing removal/installation (page 5-3)

Procedure	Q'ty	Remarks
<b>Removal Order</b>		Installation is in the reverse order of removal.
(1) Throttle cable	2	
(2) Choke cable	2	
(3) Fuel tube	1	
(4) Evaporative Emission Canister tube	1	California model only.
(5) Evaporative Emission Carburetor Air Vent Control Valve	1	California model only.
(6) Evaporative Emission Purge Control Valve	1	• Removed as an assembly from the mounting bracket.
(7) Connecting tube band screw	2	Only loosen.
(8) Sub-air cleaner housing mounting bolt/nut	2/2	
(9) Carburetor assembly	1	

## Carburetor Vacuum Tube Routing

Except California Model:

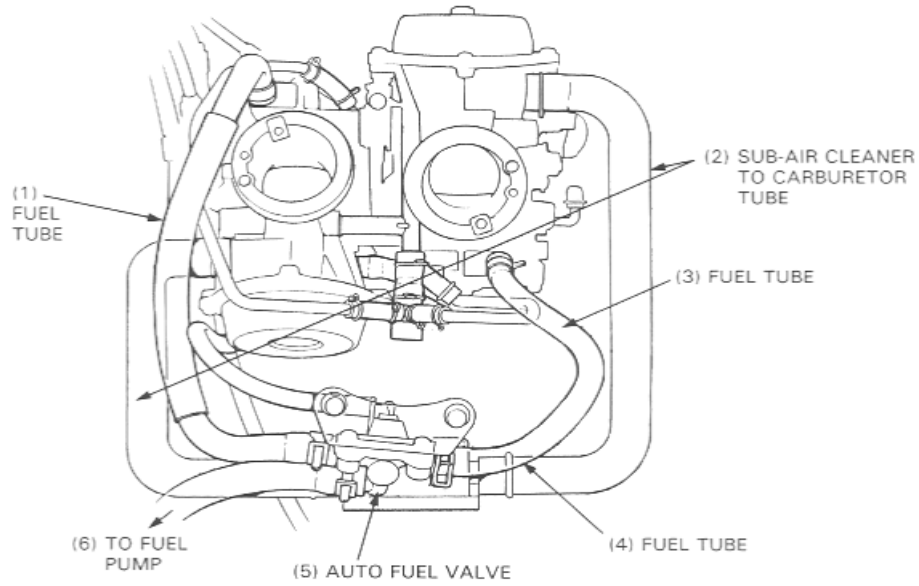

California Model Only:

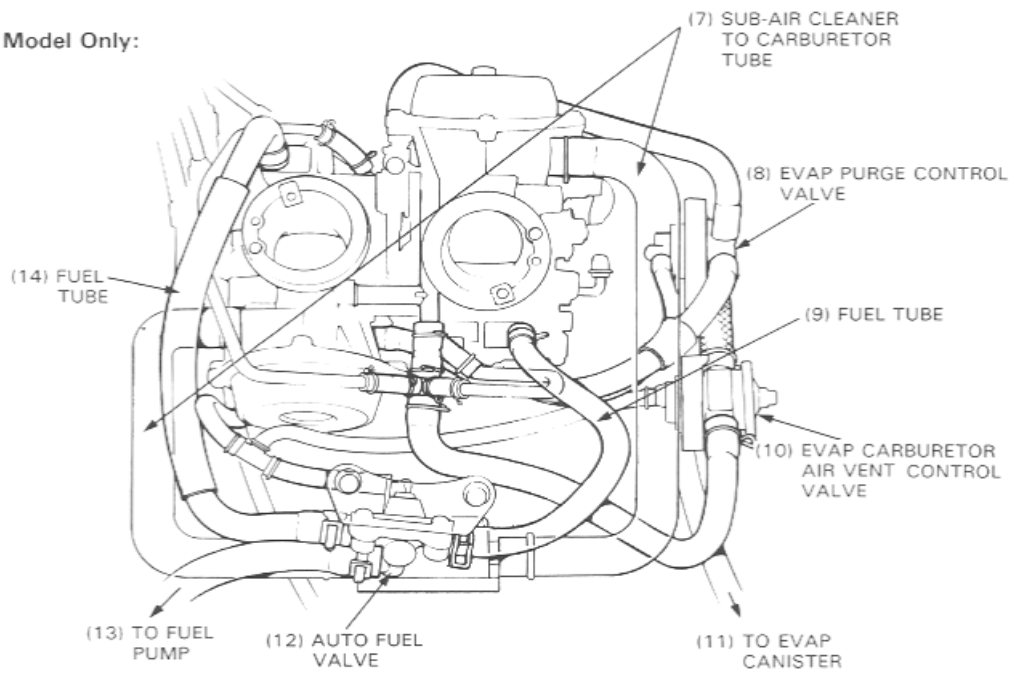

## Carburetor Separation/Combination

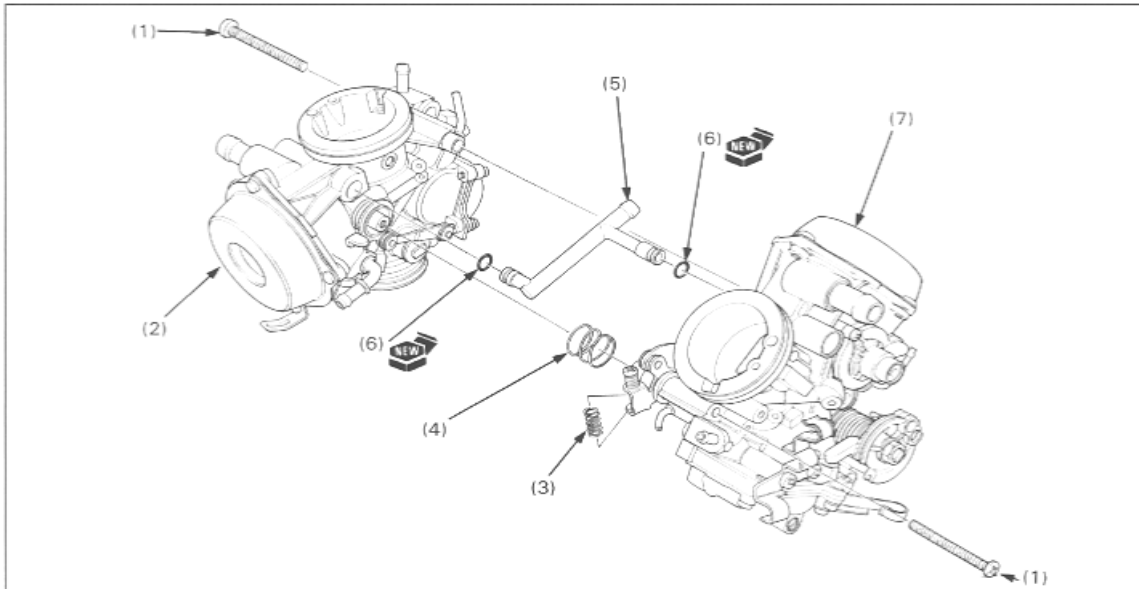

### Requisite Service

- Carburetor removal/installation (page 5-4)

Procedure		Q'ty	Remarks
<b>Separation Order</b>			
(1)	Screw	2	Carefully separate the No. 1 carburetor.
(2)	No. 2 carburetor	1	
(3)	Synchronization spring	1	
(4)	Thrust spring	1	
(5)	Air joint pipe	1	
(6)	O-ring	2	
(7)	No. 1 carburetor	1	
<b>Combination Order</b>			
(7)	No. 1 carburetor	1	Install them air joint pipe.
(6)	O-ring	2	
(5)	Air joint pipe	1	Put the No. 1 and No. 2 carburetors together with the air joint pipe, thrust collar and spring.
(4)	Thrust spring	1	
(2)	No. 2 carburetor	1	
(3)	Synchronization spring	1	
(1)	Screw	2	NOTE • Loosen the synchronization adjusting screw until there is no tension, then install it.

# Carburetor Disassembly/Assembly

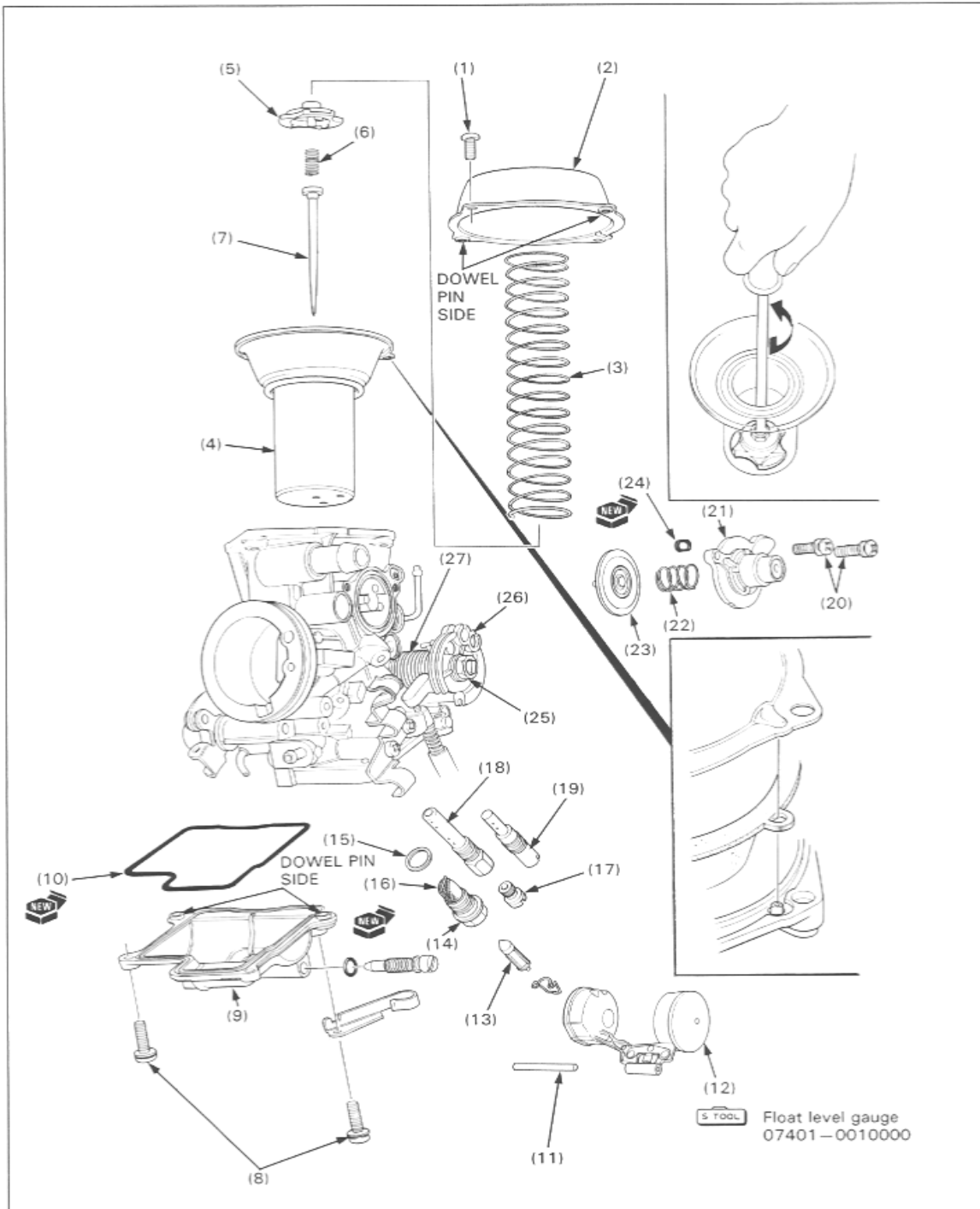

NOTE

- The vacuum chamber and float chamber can be serviced with the carburetor assembled.
- The pilot screws are factory pre-set and should not be removed unless the carburetors are overhauled.
- The pilot screw plugs are factory installed to prevent pilot screw misadjustment. Do not remove the plugs unless the pilot screws are being removed.

Requisite Service

- Carburetor separation/combination (page 5-7)

Procedure		Q'ty	Remarks
<b>Vacuum Chamber Disassembly Order</b>			Assembly is in the reverse order of disassembly.
(1)	Screw	4	<p>NOTE</p> <ul style="list-style-type: none"> <li>• At installation, hold the piston almost full to avoid pinching the diaphragm with the chamber.</li> </ul> <p>NOTE</p> <ul style="list-style-type: none"> <li>• Install the vacuum piston with the tab of the diaphragm aligned with the groove of the carburetor.</li> </ul>
(2)	Vacuum chamber cover	1	
(3)	Compression spring	1	
(4)	Diaphragm/piston	1	
(5)	Needle holder	1	
(6)	Spring	1	
(7)	Jet needle	1	
<b>Float Chamber Disassembly Order</b>			<p>NOTE</p> <ul style="list-style-type: none"> <li>• Refer to the Common Service Manual, section 8, for float level inspection. (Use carburetor float level gauge: 07401-0010000)</li> </ul> <p>Install it into the float tongue.</p>
(8)	Screw	4	
(9)	Float chamber	1	
(10)	O-ring	1	
(11)	Float pin	1	
(12)	Float	1	
(13)	Float valve	1	
(14)	Float valve seat	1	
(15)	Gasket	1	
(16)	Filter	1	
(17)	Main jet	1	
(18)	Needle jet holder	1	
(19)	Slow jet	1	
<b>Air Cut Off Valve Disassembly Order</b>			Be sure the diaphragm and spring are properly seated, then tighten it.
(20)	Screw	2	
(21)	Air cut-off valve cover	1	
(22)	Spring	1	
(23)	Diaphragm	1	
(24)	O-ring	1	
<b>Throttle Drum Disassembly Order</b>			After installation, secure tighten it.
(25)	Nut	1	
(26)	Throttle drum	1	
(27)	Return spring	1	

## Pilot Screw Adjustment (U.S.A. Only)

### Idle Drop Procedure

**▲ WARNING**

- If the engine must be running to do some work, make sure the area is well ventilated. Never run the engine in an enclosed area. The exhaust contains poisonous carbon monoxide gas that may cause loss of consciousness and lead to death.

**NOTE**

- Make sure the carburetor synchronization is within specification before pilot screw adjustment.
- The pilot screws are factory pre-set and no adjustment is necessary unless the pilot screws are replaced.
- Use a tachometer with graduations of 50 rpm or smaller that will accurately indicate a 50 rpm change.

1. Turn each pilot screw clockwise until it seats lightly, then back it out to the specification given. This is an initial setting prior to the final pilot screw adjustment.

Initial Opening: 1-1/8 turns out

**CAUTION**

- Damage to the pilot screw seat will occur if the pilot screw is tightened against the seat.

2. Warm up the engine to operating temperature. Stop and go riding for 10 minutes is sufficient.
3. Attach a tachometer according to its manufacturer's instructions.
4. Adjust the idle speed to the specified rpm with the throttle stop screw.

Idle Speed: 1,200 ± 100 rpm

5. Turn each pilot screw 1/2 turn counterclockwise from the initial setting.
6. If the engine speed increases by 50 rpm or more, turn each pilot screw out by successive 1/2 turn increments until engine speed does not increase.
7. Adjust the idle speed with the throttle stop screw.
8. Turn the No. 1 carburetor pilot screw in until the engine speed drops 50 rpm.
9. Then turn the No. 1 carburetor pilot screw counterclockwise 1/4 turn from the position obtained in step 8.
10. Adjust the idle speed with the throttle stop screw.
11. Perform steps 8, 9 and 10 for the No. 2 carburetor pilot screw.
12. Apply Loctite 601 or equivalent to the inside of the limiter caps. Place the caps over the pilot screws so that they can be turned clockwise only. This will prevent adjustment in the counterclockwise direction which richens the fuel mixture.

**NOTE**

- Be careful not to turn the pilot screw when installing the limiter cap.

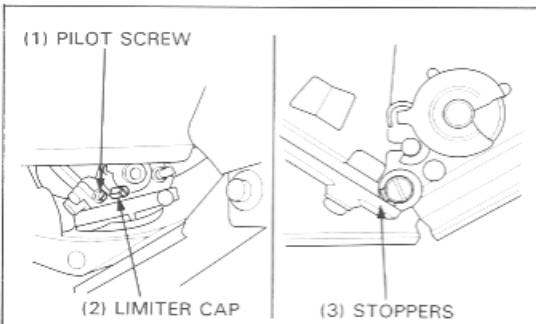
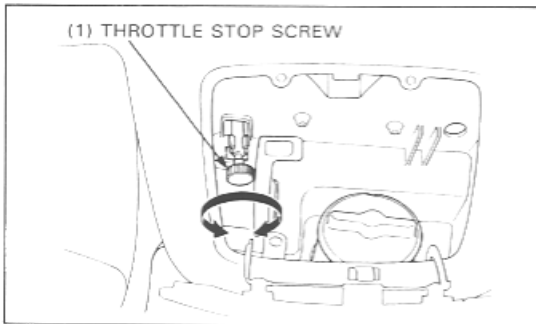
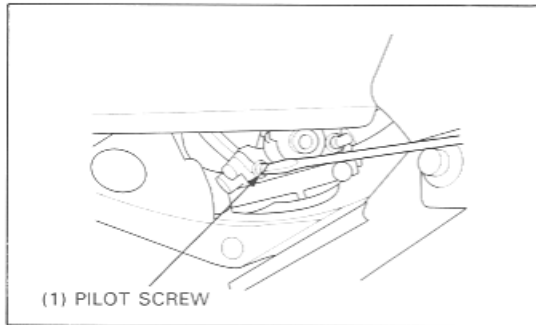
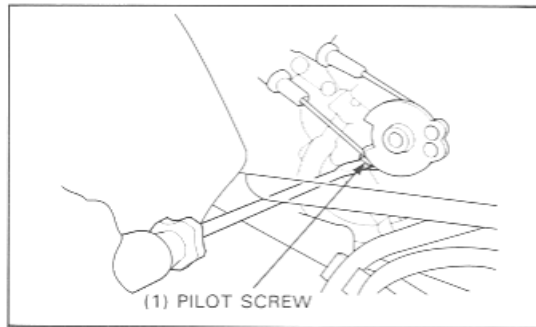

## High Altitude Adjustment (U.S.A. Only)

When the vehicle is to be operated continuously above 2,000 m (6,500 feet), the carburetor must be readjusted as follows to improve driveability and decrease exhaust emissions. Warm up the engine to operating temperature. Stop and go riding for 10 minutes is sufficient. Turn each pilot screw clockwise 1/2 turn. Adjust the idle speed to 1,200 ± 100 rpm with the throttle stop screw.

High Altitude Setting: 1/2 turn in

### NOTE

- This adjustment must be made at high altitude to ensure proper high altitude operation.

Attach a Vehicle Emission Control Information Update Label onto the right side of the frame as shown in the label position illustration.

### NOTE

- Do not attach the label to any part that can be easily removed from the vehicle.

### ⚠ WARNING

- Operation at an altitude lower than 1,500 m (5,000 feet) with the carburetors adjusted for high altitudes may cause the engine to idle roughly and the engine may stall in traffic.

When the vehicle is to be operated continuously below 1,500 m (5,000 feet), turn each pilot screw counterclockwise 1/2 turn to its original position and adjust the idle speed to 1,200 ± 100 rpm. Be sure to make these adjustments at low altitude. Remove the Vehicle Emission Control Information Update Label that is attached to the right side of the frame after adjusting for low altitude.

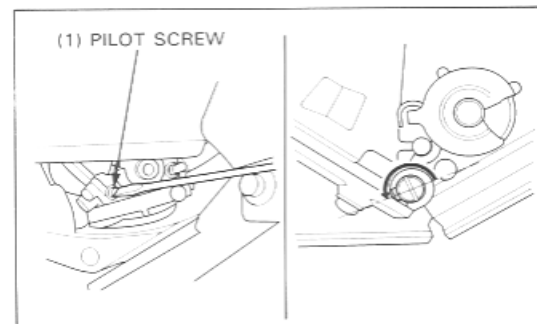
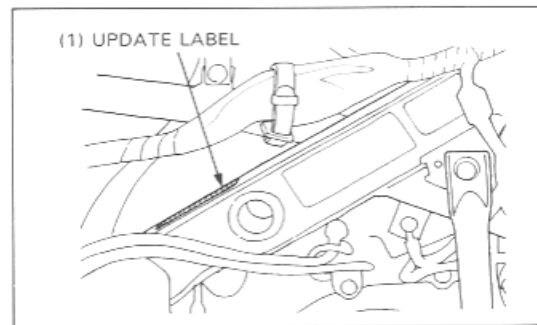
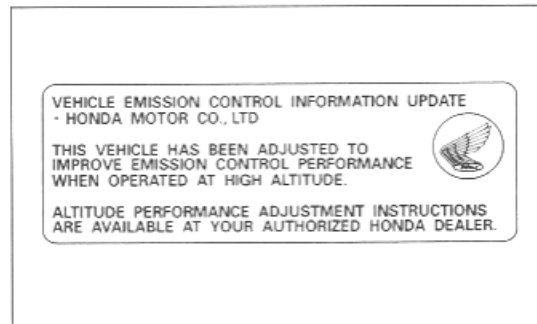
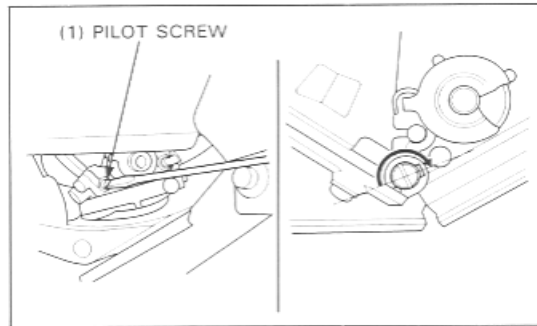

## Carburetor Draining

Open the trunk and remove the seat (page 2-17).  
Remove the air duct/maintenance lids (page 2-4).  
Remove the side covers (page 2-4).

Place a suitable container to collect gasoline under the carburetor drain tubes, located just in front of the side stand.

Using a 14 mm flat blade screwdriver, reach in the left side between the top clip for the air duct and the bottom of the meter visor. Move the throttle stop cable with the screwdriver to reach the drain screw.

Loosen the drain screw and let all of the fuel drain from the carburetor, then tighten the screw.

On the right side, position the screwdriver above the frame, behind the meter visor.

On California models, the screwdriver must be just behind the EVAP CAV control valve.

Loosen the drain screw and let all of the fuel drain from the carburetor, then tighten the screw.

Dispose of the gasoline properly.

Open the trunk lid and locate the group of connectors on the left side of the bike in front of the storage compartment. Disconnect the fuel pump connector: the inboard, rear connector of the group. It is a black two-pin connector with Black/Blue and Green wires.

Pull up the choke knob, turn the ignition on, and press the starter button to draw the remaining fuel out of the jets. Try to start the bike a few times (it won't start, or will start and stop right away).

Reconnect the fuel pump and reinstall all removed parts.

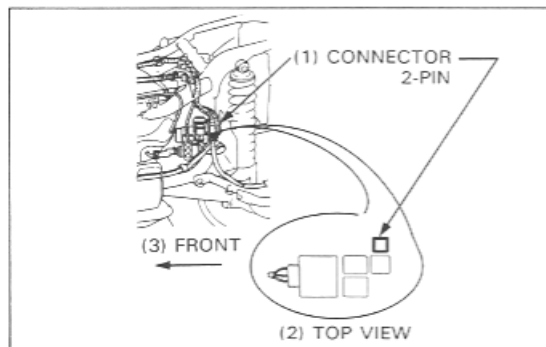
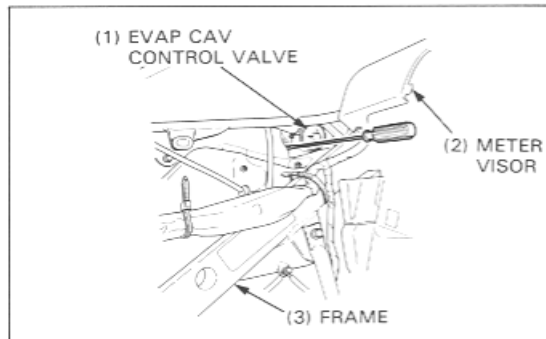
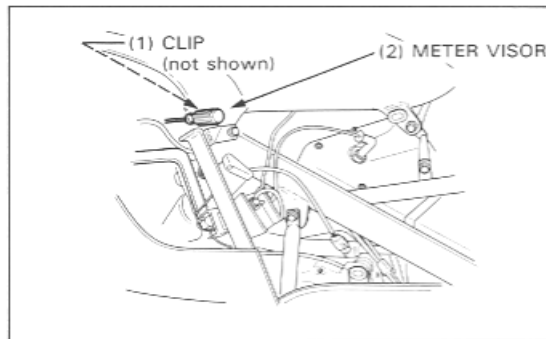

---

## 6. Cooling System

Service Information	6-1	Radiator Disassembly/Assembly	6-5
Troubleshooting	6-1	Radiator Reserve Tank Removal/ Installation	6-6
Coolant Draining	6-2	Thermostat Removal/Installation	6-7
Water Pump Removal/Installation	6-3		
Radiator Removal/Installation	6-4		

### Service Information

**6****▲ WARNING**

- Wait until the engine is cool before slowly removing the radiator cap. Removing the cap while the engine is hot and the coolant is under pressure may cause serious scalding.
- Radiator coolant is toxic. Keep it away from eyes, mouth, skin and clothes.
  - If any coolant gets in your eyes, rinse them with water and consult a doctor immediately.
  - If any coolant is swallowed, induce vomiting, gargle and consult a physician immediately.
  - If any coolant gets on your skin or clothes, rinse thoroughly with plenty of water.
- KEEP OUT OF REACH OF CHILDREN.

- Add coolant at the reserve tank. Do not remove the radiator cap except to refill or drain the system.
- All cooling system service can be made with the engine in the frame.
- Avoid spilling coolant on painted surfaces.
- After servicing the system, check for leaks with a cooling system tester.
- Refer to section 18 for fan motor switch and thermo sensor inspections.
- Refer to section 7 for radiator shroud removal and installation.

### Troubleshooting

**Engine Temperature Too High**

- Faulty radiator cap.
- Insufficient coolant.
- Passages blocked in radiator, hoses, or water jacket.
- Air in system.
- Faulty water pump.
- Thermostat stuck closed.
- Faulty temperature gauge or thermo sensor.
- Faulty cooling fan motor.
- Faulty fan motor switch.

**Engine Temperature Too Low**

- Faulty temperature gauge or gauge sensor.
- Thermostat stuck open.
- Faulty cooling fan motor switch (see section 18).

**Coolant Leaks**

- Faulty pump mechanical seal.
- Deteriorated O-rings.
- Faulty radiator cap.
- Damaged or deteriorated gasket.
- Loose hose connection or clamp.
- Damaged or deteriorated hoses.

---

**6-1**

## Coolant Draining

**⚠ WARNING**

- Wait until the engine is cool before servicing the cooling system. Removing the radiator cap while the engine is hot and the coolant is under pressure may cause serious scalding.

**NOTE**

- For coolant replacement, refer to section 5 of the Common Service Manual.

Remove the left lower cover (Section 2).  
Remove the water pump drain bolt and sealing washer.

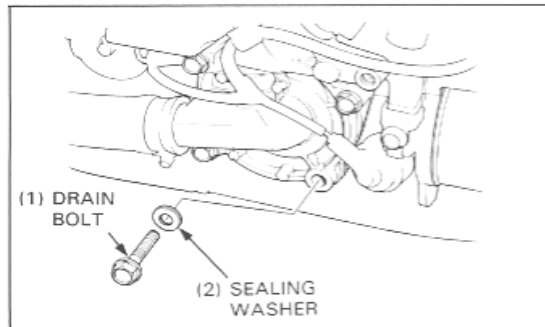

Remove the radiator cap and drain the coolant.

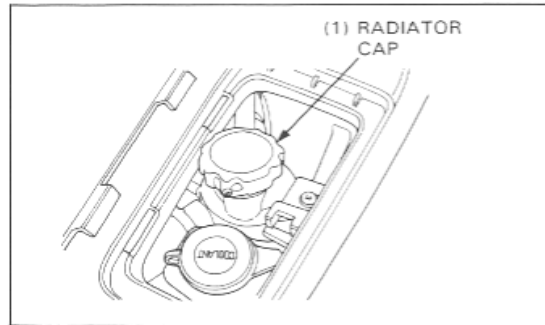

Remove the reserve tank mounting bolt (page 6-6).

Place a suitable tray under the siphon tube joint of the reserve tank and disconnect the siphon tube from the reserve tank.  
Drain the coolant from the reserve tank.

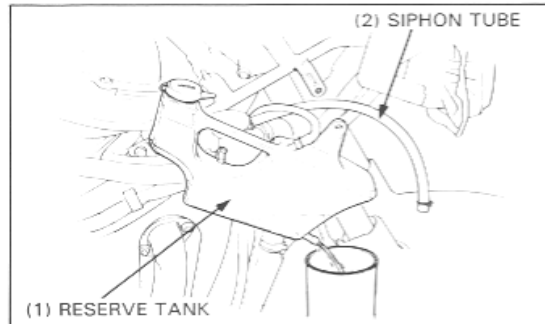

Install the water pump drain bolt with a new sealing washer, and connect the siphon tube to the reserve tank.

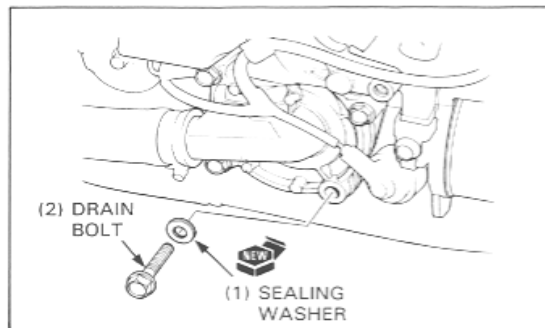

## Water Pump Removal/Installation

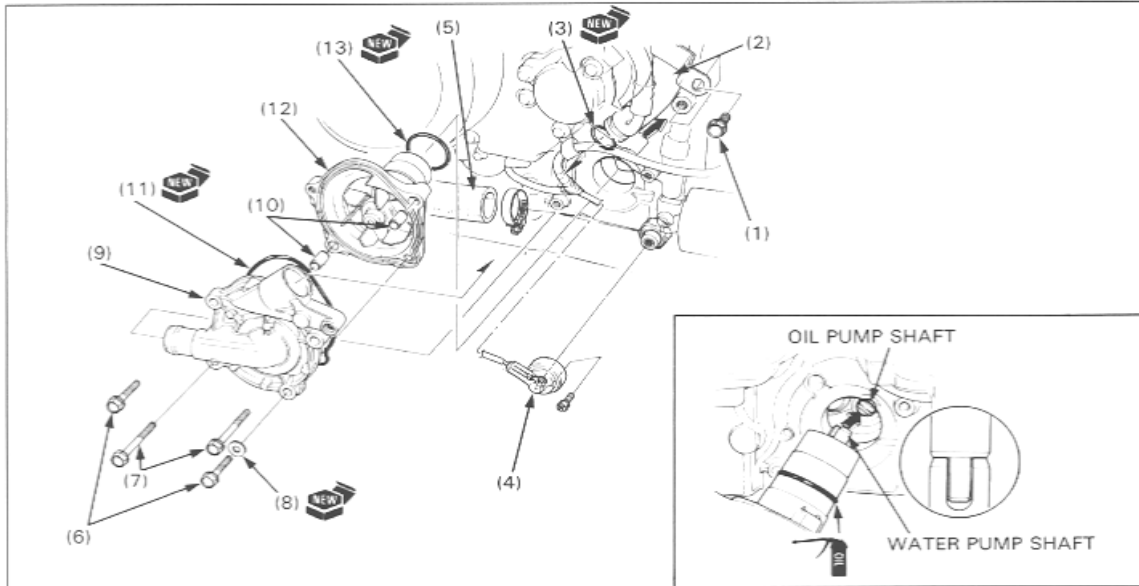

**NOTE**

- Replace the water pump as an assembly if the mechanical seal is leaking or there is evidence of bearing deterioration.

**Requisite Service**

- Coolant draining (page 6-2)
- Engine oil draining (drain bolt location: page 3-3, step section 2 of the Common Service Manual)
- Sub-frame removal/installation (page 7-4)
- Coolant refill (section 5 of the Common Service Manual)

Procedure	Q'ty	Remarks
<b>Removal Order</b>		Installation is in the reverse order of removal.
(1) Water pipe bolt	1	
(2) Water pipe	1	
(3) O-ring	1	
(4) Oil pressure switch wire	1	
(5) Radiator lower hose	1	Loosen the hose band, then remove it.
(6) Water pump cover bolt	2	
(7) Water pump mounting bolt	2	<b>NOTE</b> •At installation, apply a locking agent to the threads.
(8) Sealing washer	1	
(9) Water pump cover	1	
(10) Dowel pin	2	
(11) O-ring	1	
(12) Water pump assembly	1	Do not disassemble.
(13) O-ring	1	

## Radiator Removal/Installation

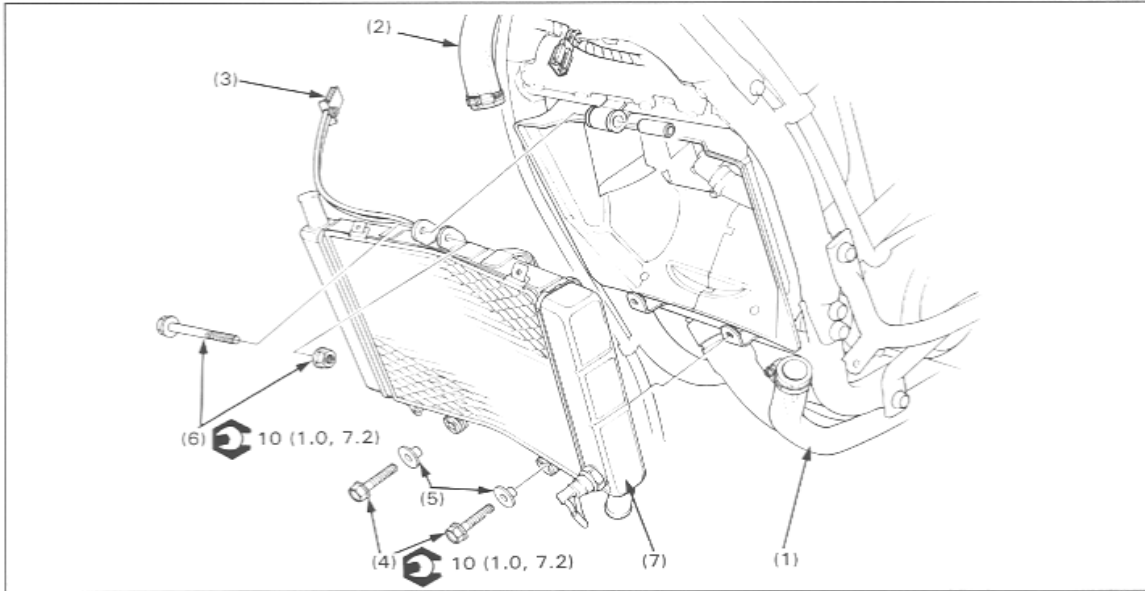

### Requisite Service

- Front upper cowl removal/installation (Section 2)
- Coolant draining (page 6-2)
- Coolant refill (Section 5 of the Common Service Manual)

Procedure	Q'ty	Remarks
<b>Removal Order</b>		Installation is in the reverse order of removal.
(1) Radiator lower hose	1	
(2) Radiator upper hose	1	
(3) Fan motor switch connector	1	
(4) Radiator lower mounting bolt	2	
(5) Collar	2	
(6) Radiator upper mounting bolt/nut	1/1	
(7) Radiator assembly	1	

## Radiator Disassembly/Assembly

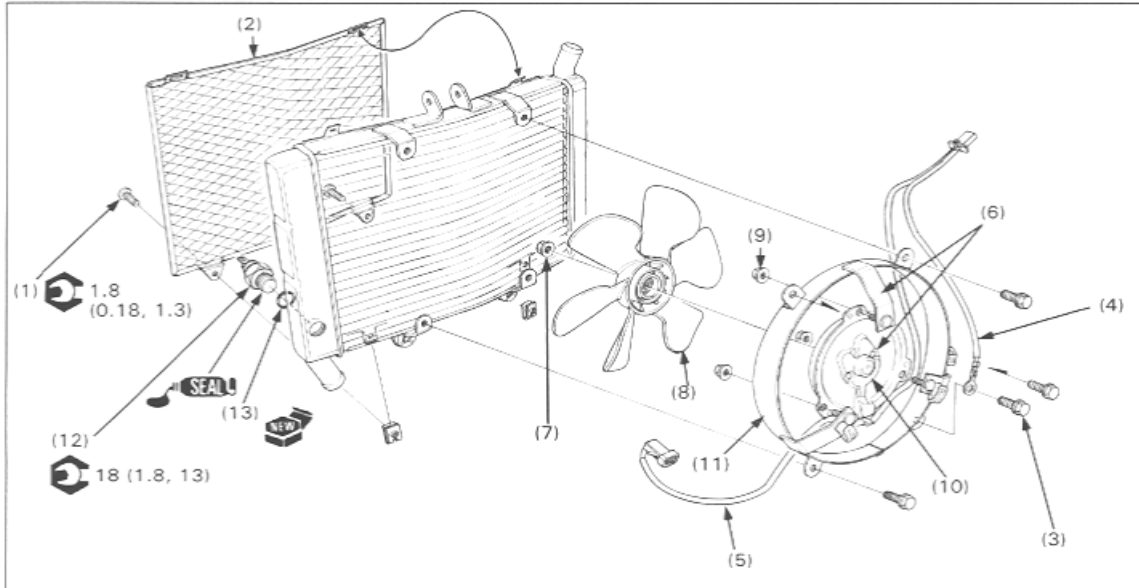

### Requisite Service

- Radiator removal/installation (page 6-4)

Procedure	Q'ty	Remarks
<b>Disassembly Order</b>		Assembly is in the reverse order of disassembly.
(1) Screw	2	
(2) Radiator grill	1	
(3) Fan motor frame mounting bolt	4	At installation, attach the ground wire as shown.
(4) Ground wire	1	
(5) Fan motor wire	1	
(6) Fan motor assembly	1	
(7) Cooling fan mounting nut	1	
(8) Cooling fan	1	At installation, align the groove with the fan motor shaft.
(9) Fan motor mounting nut	3	
(10) Fan motor	1	
(11) Fan motor frame	1	
(12) Fan motor switch	1	At installation, apply sealant to the threads.
(13) O-ring	1	

## Radiator Reserve Tank Removal/Installation

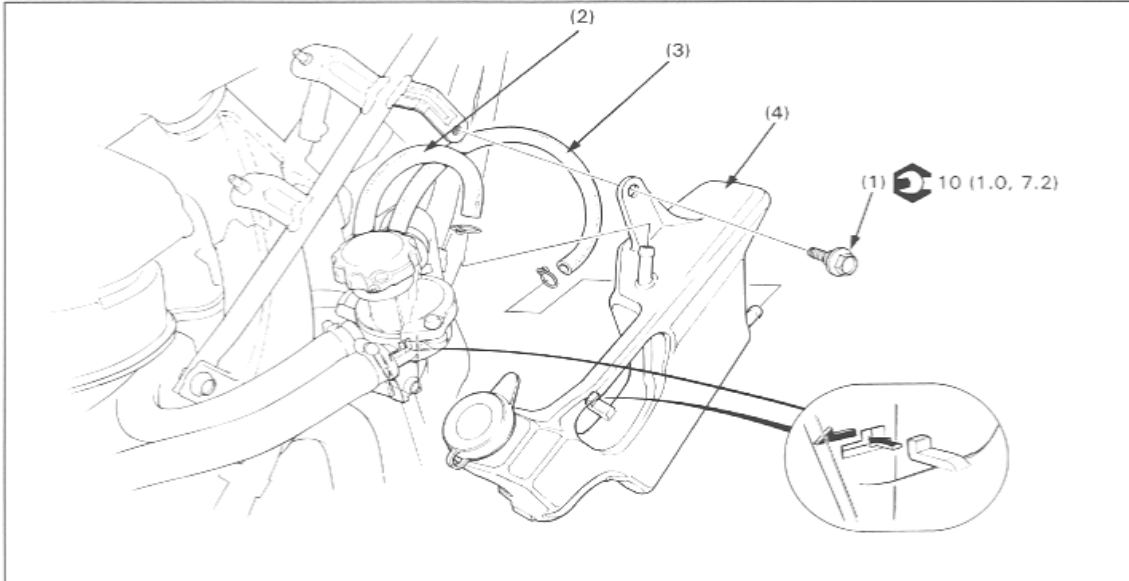

### Requisite Service

- Front upper cowl removal/installation (Section 2)

Procedure	Q'ty	Remarks
<b>Removal Order</b>		Installation is in the reverse order of removal.
(1) Radiator reserve tank mounting bolt	1	
(2) Over flow tube	1	
(3) Siphon tube	1	
(4) Radiator reserve tank	1	At installation, align the tab with the thermostat body groove.

## Thermostat Removal/Installation

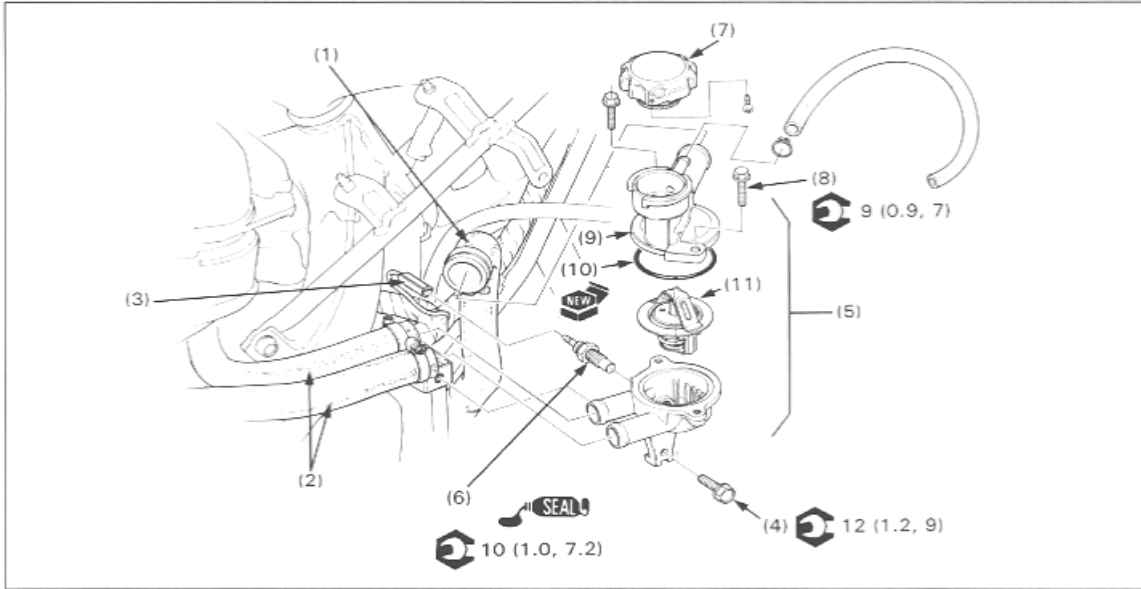

### Requisite Service

- Front upper cowl removal/installation (Section 2)
- Coolant refill (section 5 of the Common Service Manual)
- Radiator reserve tank removal/installation (page 6-6)

Procedure	Q'ty	Remarks
<b>Removal Order</b>		Installation is in the reverse order of removal.
(1) Radiator upper hose	1	
(2) Cylinder head to thermostat hose	2	
(3) Thermo sensor connector	1	
(4) Thermostat body mounting bolt	1	
(5) Thermostat body assembly	1	
(6) Thermo sensor	1	At installation, apply sealant to the threads.
(7) Radiator cap	1	Remove the tapping screw.
(8) Thermostat cover mounting bolt	2	
(9) Thermostat cover	1	
(10) O-ring	1	
(11) Thermostat	1	

---

## 7. Engine Removal/Installation

Service Information	7-1	Engine Removal	7-6
Engine Heat Cover Removal/ Installation	7-2	Engine Installation	7-8
Sub-frame Removal/Installation	7-4		

### Service Information

- A floor jack or other adjustable support is required to support and maneuver the engine.

#### CAUTION

- Do not use the oil filter as a jack point.

**7**

- Parts requiring engine removal for servicing:
  - Carburetor (Section 5)
  - Front upper cowl (Section 2)
  - Lower covers (Section 2)
  - Radiator (Section 6)
- The following components can be serviced with the engine installed in the frame.
  - Alternator (Section 15)
  - Carburetor (Section 5)
  - Camshaft (Section 8)
  - Clutch (Section 9)
  - Gearshift linkage (Section 9)
  - Oil pump (Section 4)
  - Ignition pulse generator (Section 16)
  - Starting clutch (Section 17)
  - Starter motor (Section 17)
  - Water pump (Section 6)
- The following components require engine removal for service.
  - Connecting rod (Section 10)
  - Crankshaft (Section 10)
  - Cylinder head (Section 8)
  - Cylinder, piston (Section 8)
  - Gearshift drum (Section 10)
  - Output gear (Section 10)
  - Transmission (Section 10)

## Engine Heat Cover Removal/Installation

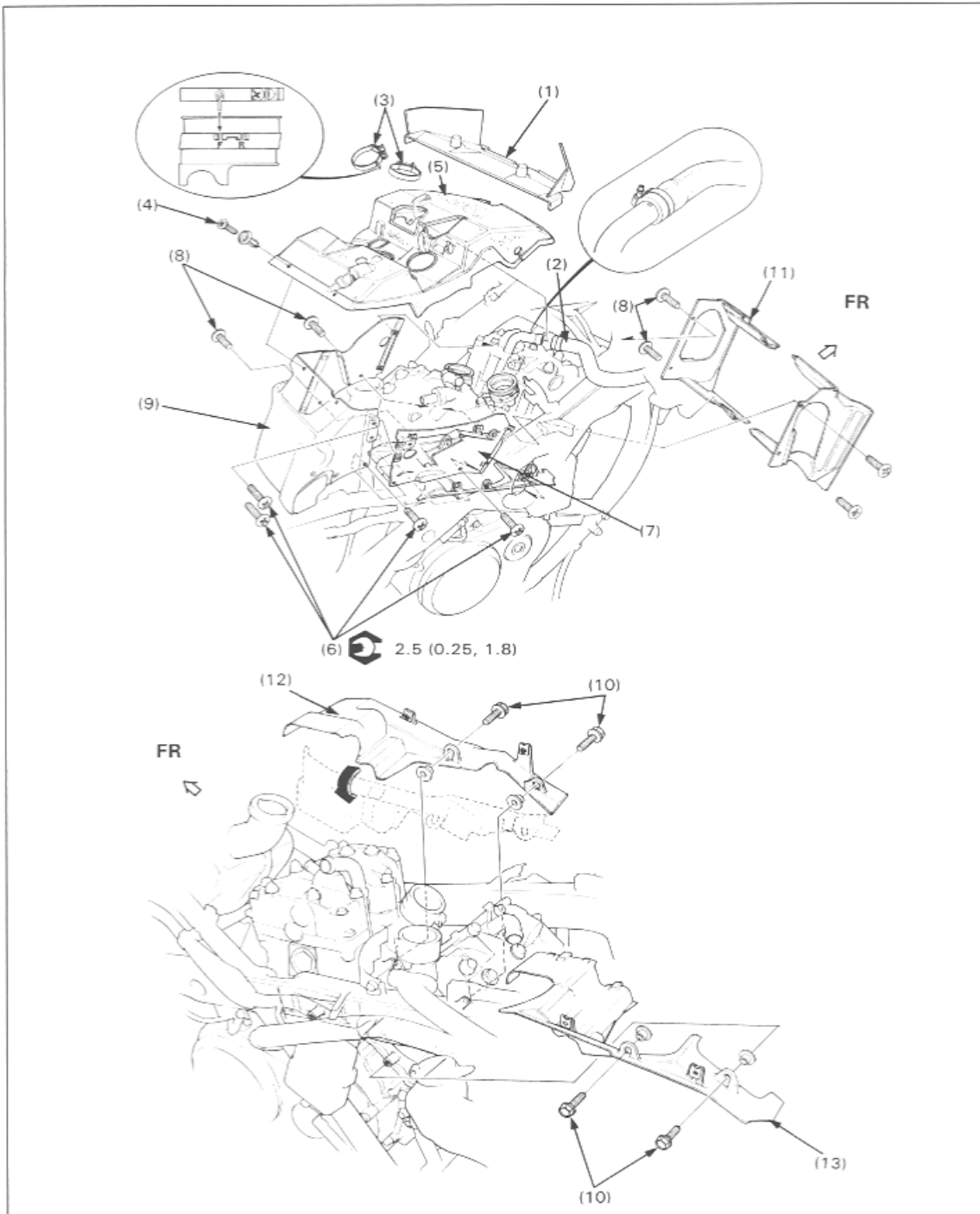

**Requisite Service**

- Top shelter removal/installation (Section 2)
- Carburetor removal/installation (page 5-4)
- Exhaust system removal/installation (Section 2)
- Top shelter frame removal/installation (page 2-28)
- Right and left lower cover removal/installation (Section 2)
- Radiator removal/installation (page 6-4)
- Evaporative emission canister removal/installation (California Model Only)

Procedure		Q'ty	Remarks
	<b>Removal Order</b>		Installation is in the reverse order of removal.
(1)	Air guide plate	1	
(2)	Water hose	2	
(3)	Carburetor insulator band	2	At installation, install the band pin into the F (front) or R (rear) mark onto the insulator.
(4)	Screw	2	
(5)	Top cover	1	
(6)	Screw	4	
(7)	Right center cover	1	
(8)	Screw	4	
(9)	Left center cover	1	
(10)	Lower cover bolt/collar	4/4	
(11)	Radiator shroud	1	
(12)	Left lower cover	1	Turn the cover about 90 degree, then remove it upwards.
(13)	Right lower cover	1	

### Sub-frame Removal/Installation

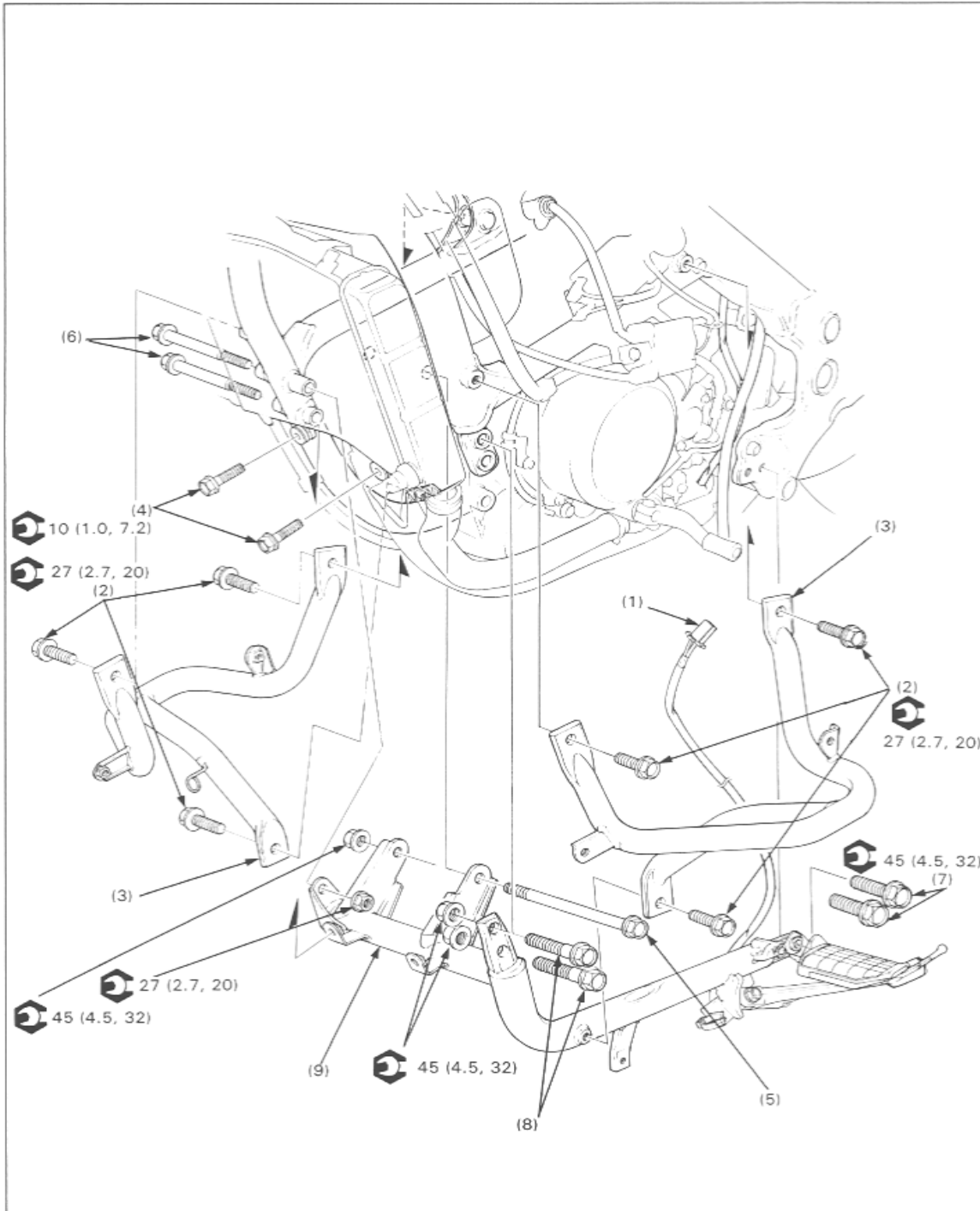

**Requisite Service**

- Front upper and lower cowl removal/installation (Section 2)
- Right and left lower cover removal/installation (Section 2)

Procedure		Q'ty	Remarks
<b>Removal Order</b>			Installation is in the reverse order of removal.
(1)	Side stand wire connector	1	NOTE • All bolts loosely install, then tighten the bolts securely.
(2)	Front bumper mounting bolt	6	
(3)	Front bumper	2	
(4)	Radiator lower mounting bolt	2	
(5)	Engine front upper mounting bolt/nut	1/1	
(6)	Engine sub-frame mounting bolt/nut	2/1	
(7)	Left sub-frame mounting bolt (rear)	2	
(8)	Left sub-frame mounting bolt (front)	2	
(9)	Sub-frame assembly	1	

## Engine Removal

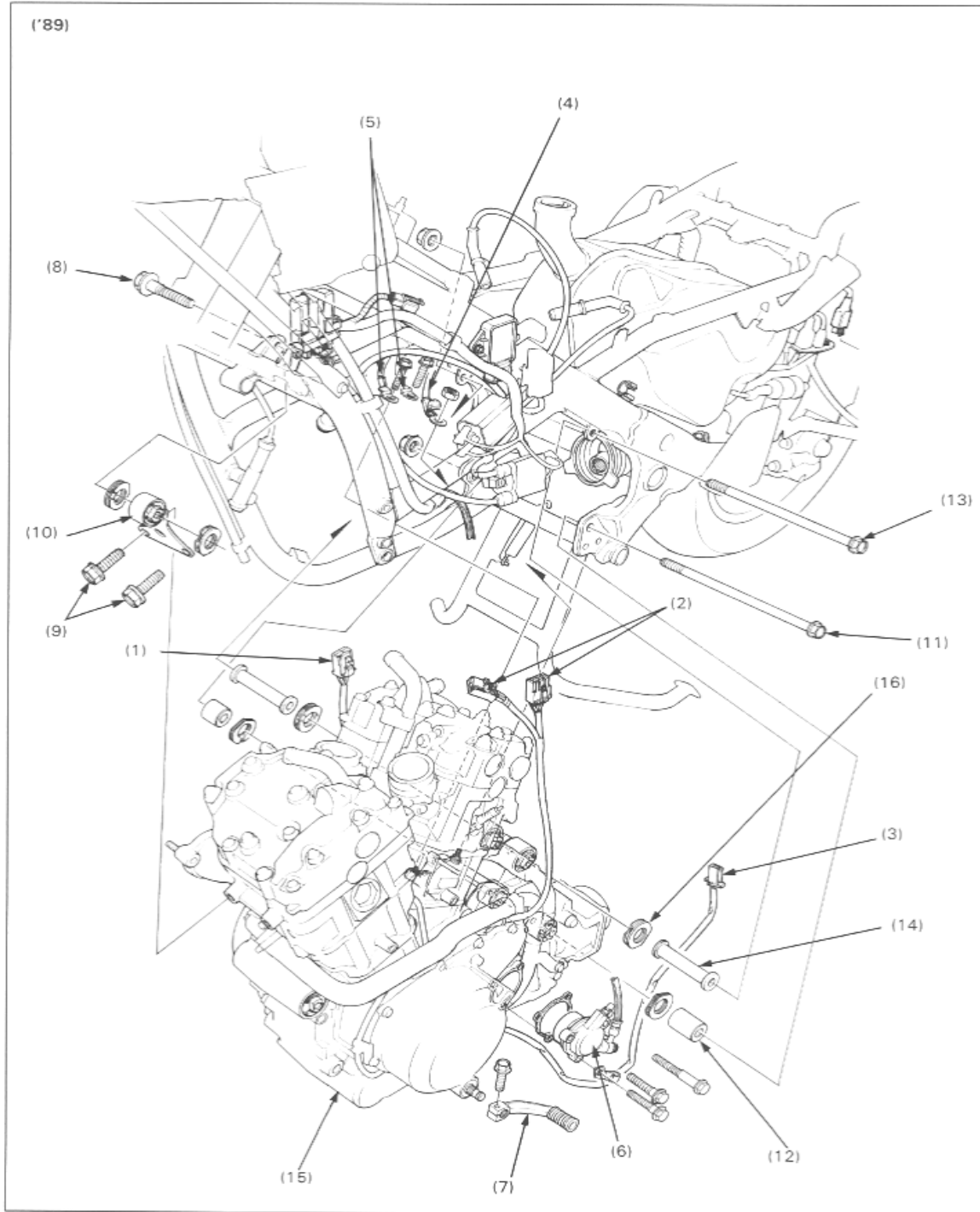

**CAUTION**

- Do not use the oil filter as a jack point.

**NOTE**

- A floor jack or other adjustable support is required to support and maneuver the engine. The jack height must be continually adjusted to relieve stress for ease of bolt removal.
- Turn the ignition switch OFF and disconnect the battery ground (-) cable.

**Requisite Service**

- Engine heat cover removal (page 7-2)
- Sub-frame removal (page 7-4)

Procedure	Q'ty	Remarks
<b>Removal Order</b>		
(1) Ignition control module (ICM) connector	1	
(2) Stator connector	2 or 1 (AFTER '89)	
(3) Neutral/oil pressure switch connector	1	
(4) Starter motor cable	1	
(5) Starter ground cable	2	
(6) Clutch slave cylinder	1	(see page 9-4) NOTE • Pull in and hold the clutch lever.
(7) Gearshift pedal	1	
(8) Engine front upper mounting bolt	1	
(9) bracket bolt	2	
(10) bracket	1	
(11) Engine rear lower mounting bolt/nut	1/1	
(12) collar	2	
(13) Engine rear upper mounting bolt/nut	1/1	
(14) collar	2	
(15) Engine assembly	1	Move the engine out of the frame to the left.
(16) Spacer	10	

# Engine Installation

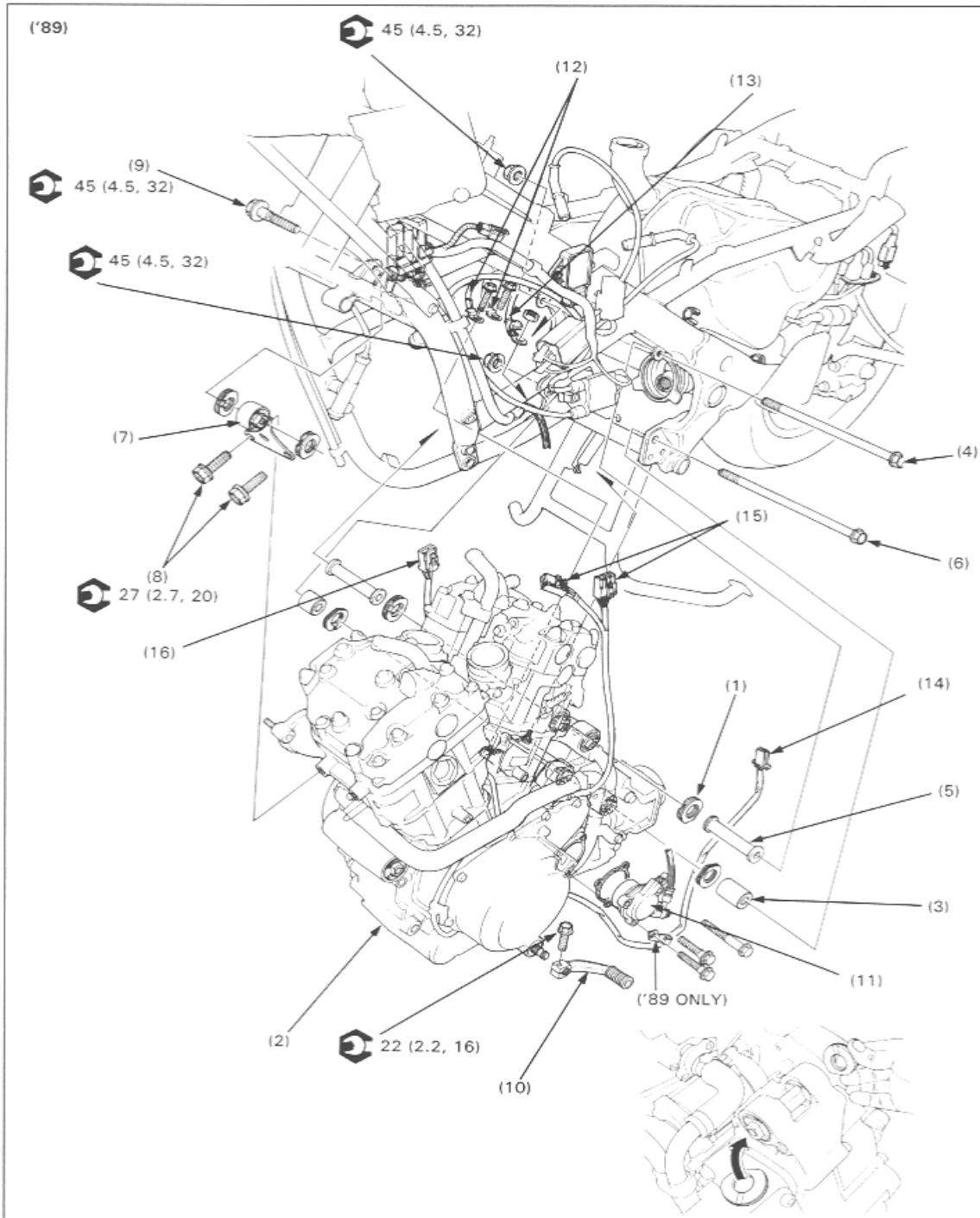

NOTE

- The jack height must be continually adjusted to relieve stress for ease of bolt installation.
- Loosely install all engine mounting bolts and nuts, then tighten the nuts to the specified torque following the proper procedure (see page 7-10).

Requisite Service

- Sub-frame installation (page 7-4)
- Engine heat cover installation (page 7-2)

Procedure		Q'ty	Remarks
<b>Installation Order</b>			
(1)	Spacer	10	Install the spacer on its groove facing the engine. <b>CAUTION</b> • Carefully align mounting points with the jack to prevent damage to mounting bolt threads, wire harness and cables. <b>NOTE</b> • Apply Molybdenum disulfide grease to the universal joint engagement splines. • Engage the output shaft with the universal joint, making sure the splines are correctly aligned.
(2)	Engine assembly	1	
(3)	Engine rear upper mounting collar	2	Install the longer collar to the left. (see page 7-10)
(4)	bolt/nut	1/1	
(5)	Engine rear lower mounting collar	2	Install the longer collar to the left.
(6)	bolt/nut	1/1	
(7)	Engine front upper mounting bracket	1	
(8)	bracket bolt	2	
(9)	bolt	1	
(10)	Gearshift pedal	1	Align the punch mark on the shift spindle slit in the shift arm. (see page 9-4)
(11)	Clutch slave cylinder	1	
(12)	Starter motor ground cable	2	
(13)	Starter motor cable	1	
(14)	Neutral/oil pressure switch connector	1	
(15)	Stator connector	2 or	
		1	'89
(16)	Ignition control module (ICM) connector	1	After '89

## Engine Removal/Installation

### Engine Mounting Bolt Tightening

#### NOTE

- The jack height must be continually adjusted to relieve stress for ease of bolt installation.

All engine mounting bolts and nuts loosely install.

Tighten the engine mounting nuts (①—④) to the specified torque.

**Torque: 45 N·m (4.5 kg-m, 32 ft-lb)**

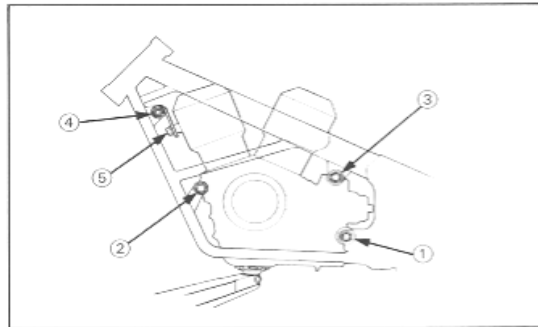

Remove the floor jack.

Tighten the engine front upper mounting bracket bolts to the specified torque.

**Torque: 27 N·m (2.7 kg-m, 20 ft-lb)**

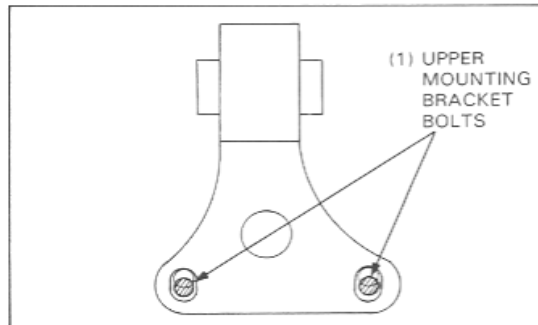

---

## 8. Cylinder Head/Cylinder/Piston

Service Information	8-1	Cylinder Head Removal/Installation	8-8
Troubleshooting	8-1	Cylinder Head Disassembly/Assembly	8-14
Cylinder Head Cover Removal/Installation	8-2	Cylinder, Piston Removal/Installation	8-16
Cylinder Head Cover Disassembly/Assembly	8-6		

### Service Information

- Camshaft service can be done with the engine in the frame.
- Camshaft lubricating oil is fed through oil passages in the cylinder head. Clean the oil passages before assembling the cylinder head.
- Clean all disassembled parts with clean solvent and dry them by blowing them off compressed air before inspection.
- When disassembling, mark and store the disassembled parts to ensure that they are reinstalled in their proper locations.
- Take care not to damage the cylinder walls and pistons.

8

### Troubleshooting

- Engine top-end problems usually affect engine performance. These can be diagnosed by a compression or leak down test, or by tracing noises to the top-end with a sounding rod or stethoscope.
- If performance is poor at low speeds, check for white smoke in the crankcase breather tube. If the tube is smokey, check for a seized piston ring.

#### Compression Too Low, Hard Starting or Poor Performance at Low Speed

- Valves
  - Incorrect valve adjustment
  - Burned or bent valves
  - Incorrect valve timing
  - Broken valve spring
  - Uneven valve seating
- Cylinder head
  - Leaking or damaged head gasket
  - Warped or cracked cylinder head
- Cylinder, piston
  - Leaking cylinder head gasket
  - Loose spark plug
  - Worn, stuck or broken piston ring
  - Worn or damaged cylinder and piston

#### Excessive Noise

- Cylinder head
  - Incorrect valve adjustment
  - Sticking valve or broken valve spring
  - Damaged or worn camshaft
  - Loose, worn or damaged camchain
  - Worn or damaged camchain tensioner
  - Worn cam sprocket teeth
  - Worn rocker arm and/or shaft
- Cylinder, piston
  - Worn cylinder and piston
  - Worn piston pin and piston pin hole

#### Rough Idle

- Low cylinder compression

#### Compression Too High, Overheating or Knocking

- Excessive carbon built-up in cylinder head or on top of piston

#### Excessive Smoke

- Cylinder head
  - Worn valve stem or valve guide
  - Damaged step seal
- Cylinder, piston
  - Worn cylinder, piston, or piston rings
  - Improper installation of piston rings
  - Scored or scratched piston or cylinder wall

## Cylinder Head Cover Removal/Installation

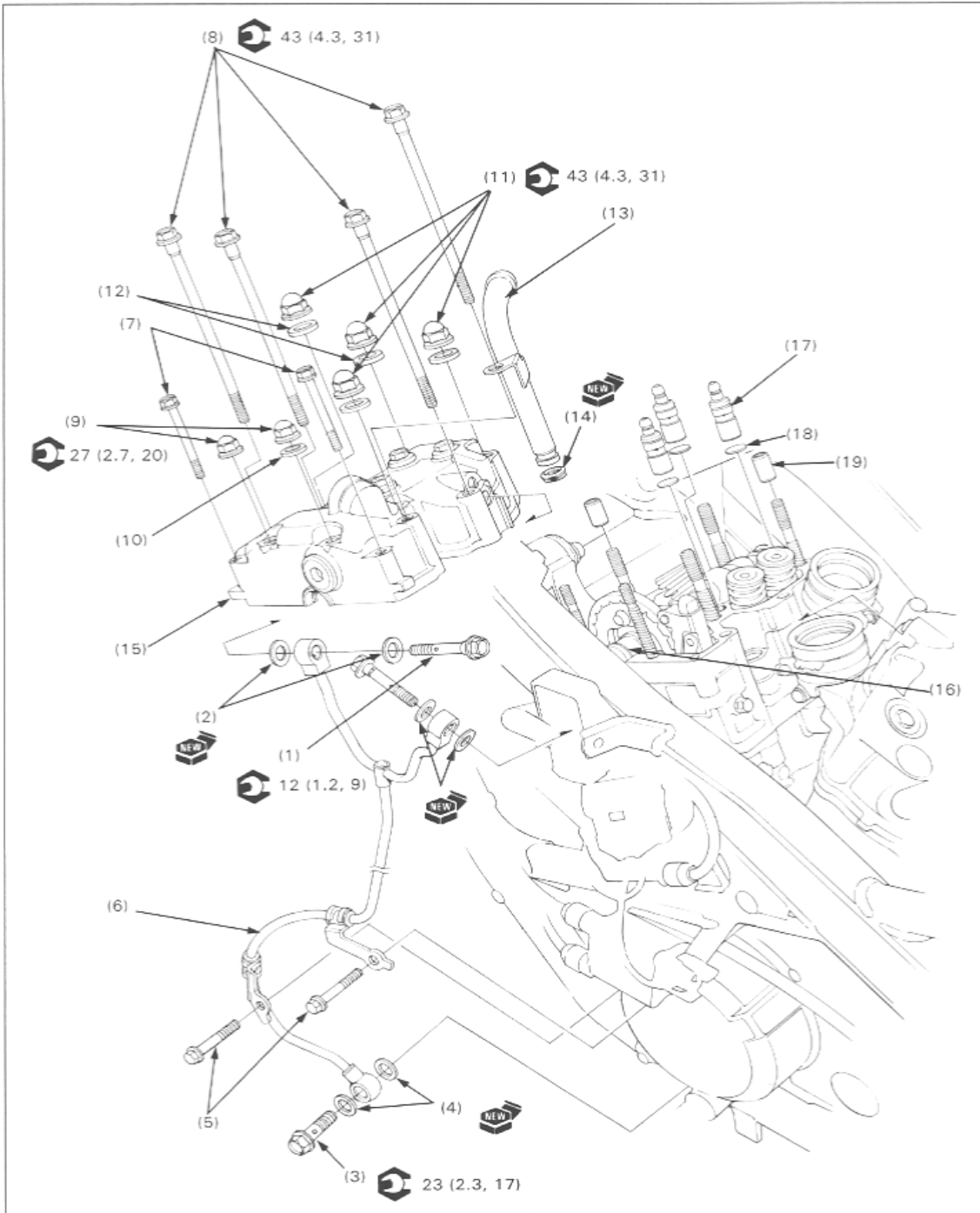

NOTE

- For rear cylinder head cover removal, necessary to remove the top shelter frame and fuel tank mounting bolt (page 2-28).

Requisite Service

- Engine heat cover (top and center) removal/installation (page 7-2)

Procedure	Q'ty	Remarks
<b>Removal Order</b>		Installation is in the reverse order of removal.
(1) Oil path pipe bolt	2	
(2) Sealing washer 7 mm	4	
(3) Oil control bolt	1	
(4) Oil bolt washer	2	
(5) Oil pipe mounting bolt (L. crankcase cover)	2	
(6) Oil pipe	1	<b>CAUTION</b> • During removal and installation, do not bend the oil pipe.
(7) Cylinder head cover 6 mm flange bolt	2	<b>NOTE</b> • Remove the bolts and nuts in crisscross pattern in 2 or 3 steps.
(8) Cylinder head cover 8 mm flange bolt	4	
(9) 8 mm cap nut	2	
(10) Sealing washer 8 mm	1	
(11) 10 mm cap nut	4	
(12) Sealing washer 10 mm	4	
(13) Water pipe	1	
(14) Water pipe seal	1	
(15) Cylinder head cover assembly	1	<b>NOTE</b> • At removal, check that the hydraulic tappets and shims stays in the cylinder head. • If the engine out of the frame, tilt the engine about 40 degrees to the right or left when removing the front or rear cylinder head cover. The hydraulic tappets and shims may come out with the cylinder head cover. Be careful not to drop them into the crankcase. • Disassembly procedure (page 8-6). • At installation, apply sealant to the mating surface. Do not apply sealant around the hydraulic tappet holes.
(16) Camshaft plug	2	
(17) Hydraulic tappet	3	<b>CAUTION</b> • Do not strike or use excessive force to remove the hydraulic tappet.
(18) Shims	—	<b>NOTE</b> • Be careful not to drop them into the crankcase.
(19) Dowel pin	2	

## Cylinder Head/Cylinder/Piston

### Hydraulic Tappet

#### Inspection

Inspect the hydraulic tappets for wear, damage and plugged holes.

Measure the free length of each hydraulic tappet as follows: Attach the Hydraulic Tappet Bleeder to the hydraulic tappet and compress and extend the hydraulic tappet slowly in a jar filled with kerosene.

#### NOTE

- Keep the hydraulic tappet below the surface of the kerosene.
- Hold the hydraulic tappet upright while compressing and extending the hydraulic tappet.

Continue priming the hydraulic tappet until the air bubbles stop and the tappet no longer collapses.

#### 5 TOOL

Hydraulic tappet bleeder 07973—MJ00000

Quickly try to compress the tappet by hand. Measure the compression stroke with the dial gauge.

Compression Stroke: 0—0.2 mm (0—0.008 in)

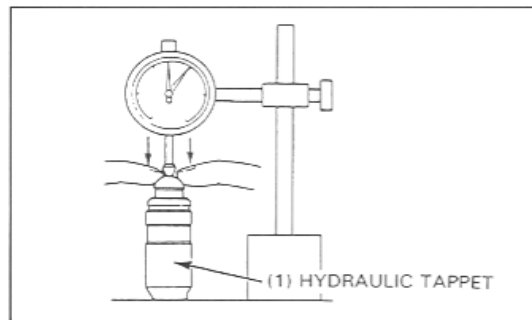
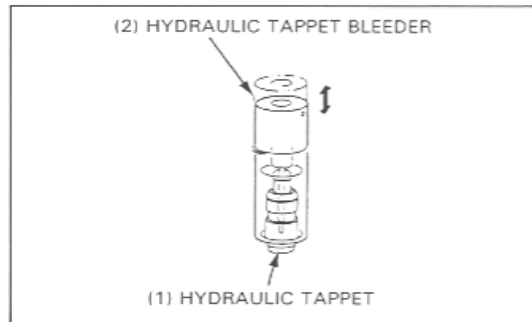

#### Adjustment

#### NOTE

- Whenever replacing the following parts, the hydraulic tappet must be adjusted with shims.
  - Cylinder head cover.
  - Cylinder head.
  - Valve stem, valve guide and valve seat refacing.
  - Rocker arm and rocker arm shaft.
  - Camshaft.

After draining the oil in the hydraulic tappets with the tappet bleeder, install the tappets into the cylinder head.

#### 5 TOOL

Hydraulic tappet bleeder 07973—MJ00000

Install the cylinder head and tighten the 6 mm bolts, 8 mm bolts and 8 mm and 10 mm cap nuts to the specified torque.

Torque: 8 mm bolt and cap nut: 27 N·m (2.7 kg·m, 20 ft·lb)  
10 mm cap nut: 43 N·m (4.3 kg·m, 31 ft·lb)

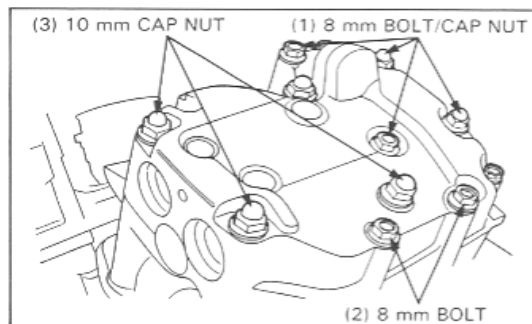
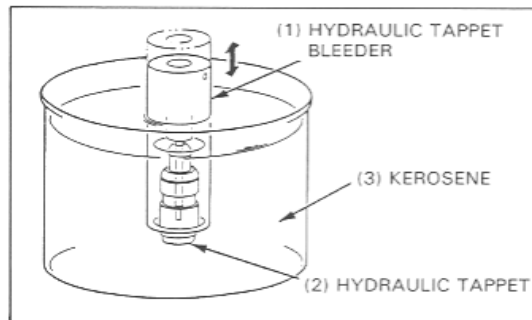

Install the assist shaft into their holes in the cylinder head cover.

Rotate the crankshaft clockwise and align the "FT" ("RT") mark with the index mark.

Install the gear holder or equivalent plate to the front or rear cylinder head cover as shown and place the dial indicator on the assist shaft.

Measure the assist shaft stroke by rotating the crankshaft clockwise two times.

NOTE

- The amount of assist shaft stroke will determine the number of tappet shims needed.

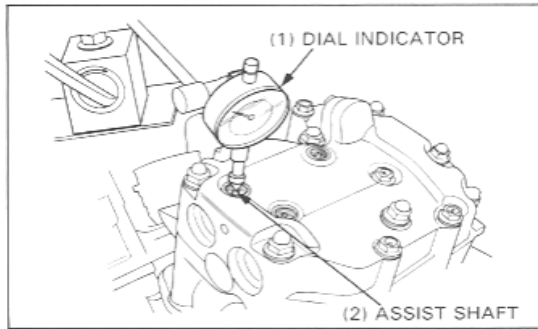

Determine and record the number of shims required for each tappet according to the following chart.

Assist shaft stroke	Number of shims needed 0.5 mm (0.02 in)
0–1.20 mm (0–0.047 in)	0
1.20–1.50 mm (0.047–0.059 in)	1
1.50–1.80 mm (0.059–0.070 in)	2
1.80–2.10 mm (0.070–0.083 in)	3
2.10–2.40 mm (0.083–0.094 in)	4
2.40–2.70 mm (0.094–0.106 in)	5

### Cylinder Head Cover Disassembly/Assembly

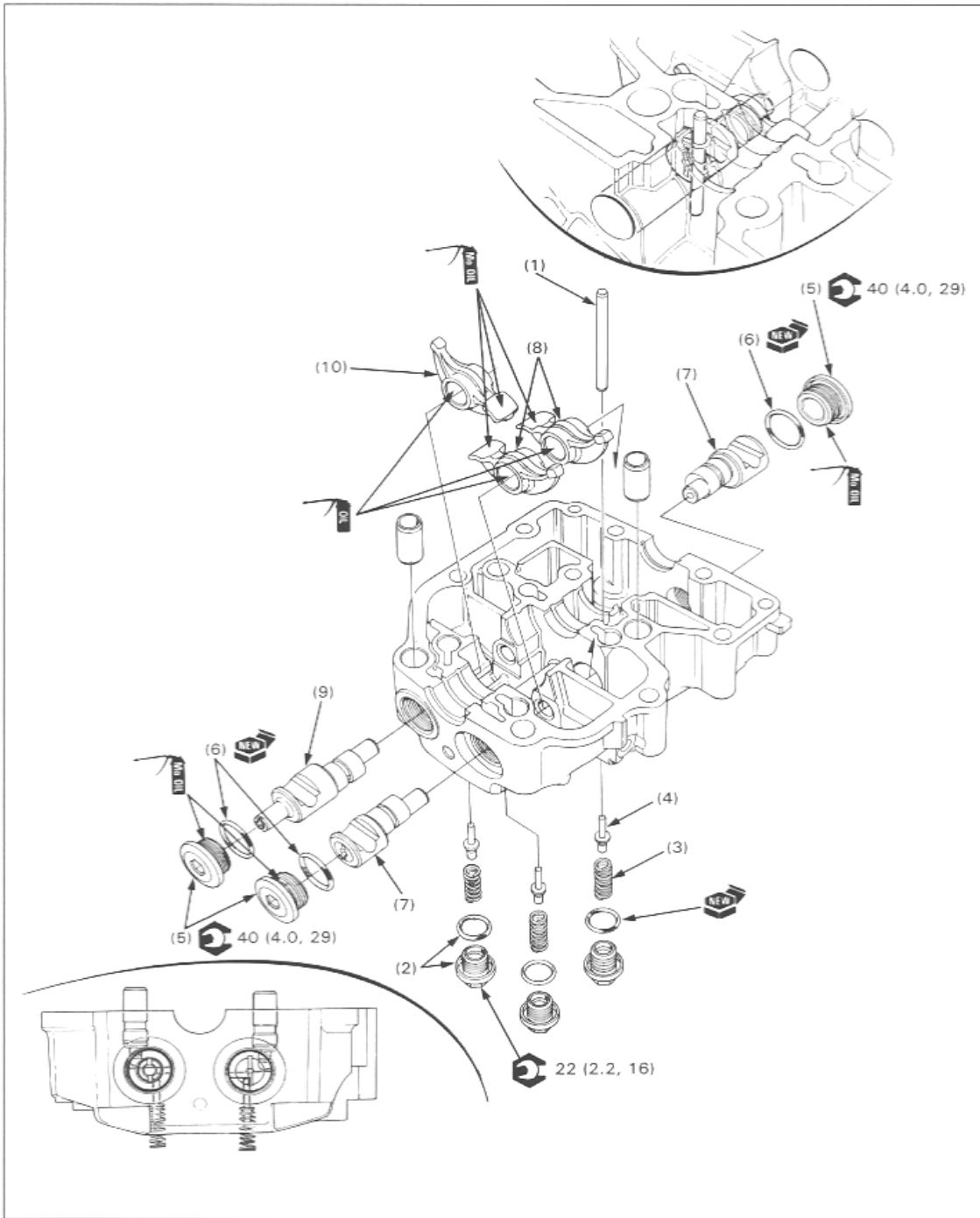

**Requisite Service**

- Cylinder head cover removal/installation (page 8-2)

Procedure	Q'ty	Remarks
<b>Disassembly Order</b>		
(1) Stopper pin	1	
(2) Assist shaft cap/O-ring	3	
(3) Assist spring	3	
(4) Assist shaft	3	
(5) Rocker arm shaft hole plug	3	
(6) O-ring	3	
(7) Intake rocker arm shaft	2	NOTE • Remove the intake rocker arm shaft on the opposite side by tapping the cylinder head cover with a plastic hammer.
(8) Intake rocker arm	2	
(9) Exhaust rocker arm shaft	1	NOTE • Thread a 6 mm bolt into the exhaust rocker arm shaft and pull the bolt to remove the shaft.
(10) Exhaust rocker arm	1	
<b>Assembly Order</b>		
(10) Exhaust rocker arm	1	NOTE • Brush Molybdenum disulfide oil on the slipper surface of the rocker arms and coat the contact surfaces of the rocker shafts with clean engine oil.
(9) Exhaust rocker arm shaft	1	Rotate the rocker arm shaft so that the arms are moved in toward the center of the cover, then install it.
(8) Intake rocker arm	2	NOTE • Put your finger on the rocker arms as you rotate the shaft to be sure which way they're moving.
(7) Intake rocker arm shaft	2	
(1) Stopper pin	1	
(6) O-ring	3	
(5) Rocker arm shaft hole plug	3	
(4) Assist shaft	3	Install into the rocker arm shaft groove as shown.
(3) Assist spring	3	
(2) Assist shaft cap/O-ring	3	

## Cylinder Head Removal/Installation

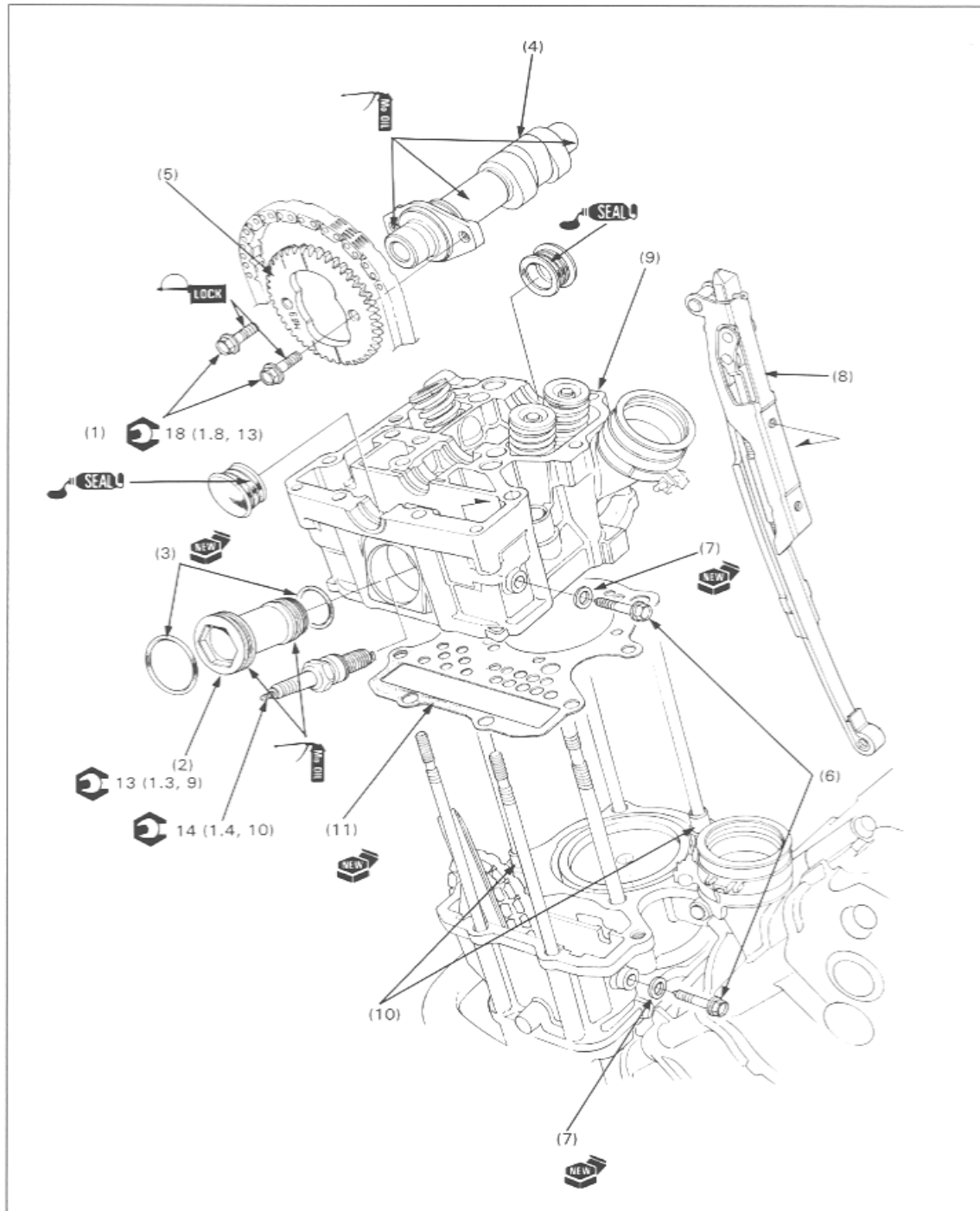

NOTE

- Camshaft and cam chain service can be done with the engine in the frame.
- Before removal, release the cam chain tensioner by pulling the wedge A straight up while holding wedge B down, then secure wedge A with a 2 mm pin (page 8-10).

Requisite Service

- Engine removal/installation (page 7-6)
- Cylinder head cover removal/installation (page 8-2)

Procedure	Q'ty	Remarks
(1) <b>Removal Order</b> Cam sprocket bolt	2	Installation is in the reverse order of removal. NOTE • Rotate the crankshaft clockwise one turn (360°) and remove the other sprocket bolt. • Be careful not to let the cam sprocket bolts fall into the crankcase.
(2) Spark plug sleeve collar	1	
(3) O-ring	2	
(4) Camshaft	1	NOTE • Rotate the crankshaft clockwise half a turn (180°), then remove it.
(5) Cam sprocket	1	NOTE • Attach the piece of wire to the cam chain to prevent it from being dropped into the crankcase, then remove it.
(6) Cam chain tensioner bolt	2	
(7) Sealing washer	2	
(8) Cam chain tensioner	1	
(9) Cylinder head assembly	1	
(10) Dowel pin	2	
(11) Gasket	1	

## Cylinder Head/Cylinder/Piston

### Cam Chain Inspection

Measure the distance of the cam chain tensioner projection above the bracket as shown.

Replace the cam chain with a new one if the projection exceeds 9 mm (0.35 in).

To replace the cam chain, remove the following parts.

Front cylinder: Starter driven gear (page 17-8).

Rear cylinder : Primary drive gear (page 9-6).

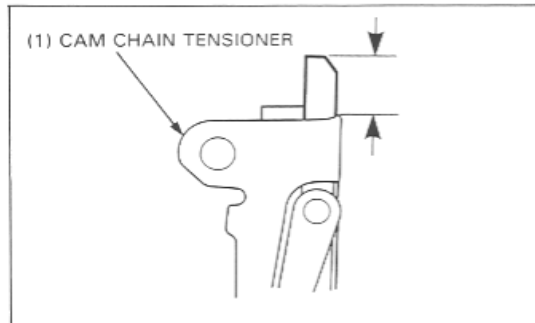

### Camshaft Removal

Release the cam chain tensioner by pulling wedge A straight up while holding wedge B down, then secure wedge A with a 2 mm pin as shown.

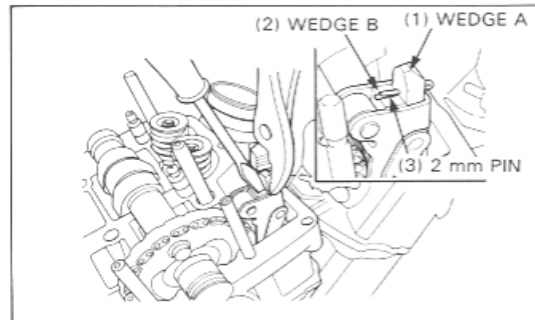

Remove the cam sprocket bolt.

Rotate the crankshaft clockwise one turn (360°) and remove the other cam sprocket bolt.

#### NOTE

- Be careful not to let the cam sprocket bolt fall into the crankcase.

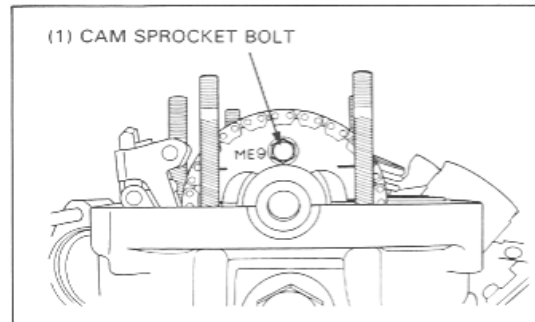

Remove the cam sprocket from the camshaft flange with the cam chain.

Rotate the crankshaft clockwise half a turn (180°) and remove the camshaft from the cam sprocket.

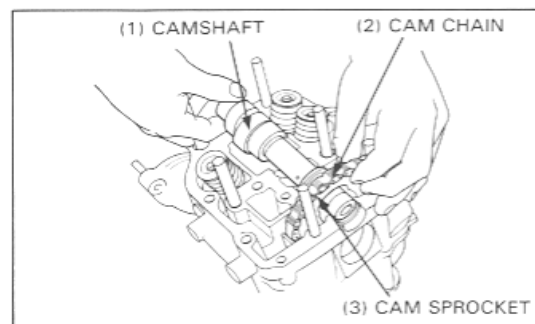



Remove the spark plug.  
Remove the spark plug sleeve from the spark plug hole on the cam chain side using the special tool.

**5 TOOL**

Fork tube holder attachment 07930-KA50100

Attach a piece of wire to the cam chain to prevent it from being dropped into the crankcase, and remove the cam sprocket.

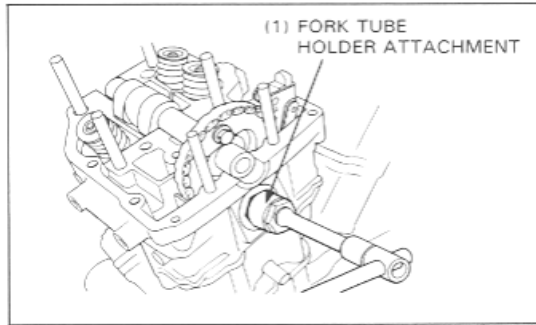

### Camshaft Installation

Lubricate the camshaft journal surface of the cylinder head with molybdenum disulfide oil.

#### NOTE

- If both front and rear camshafts were removed, start the installation with the front cylinder as described below.
- Even if you are servicing either the front or rear cylinder head, the other cylinder head cover must be removed and the other camshaft position must be checked.

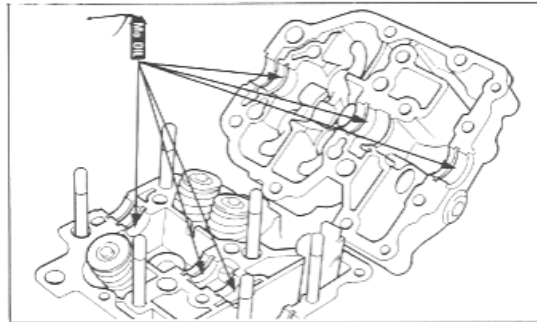

#### Front Cylinder Camshaft Installation

Turn the crankshaft clockwise and align the "RT" mark on the primary drive gear with the index mark on the right crankcase cover.  
Make sure the "R" mark on the rear camshaft is facing DOWN (cannot be seen).

If the "R" mark is facing up, turn the crankshaft clockwise one revolution so that the "R" mark is facing down.

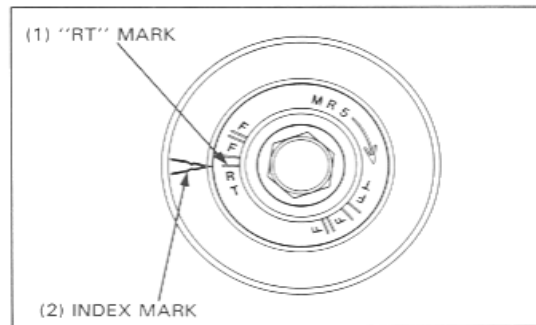

Next turn the crankshaft clockwise approximately 3/8 turn until the "FT" mark on the primary drive gear and the index mark on the right crankcase cover align.

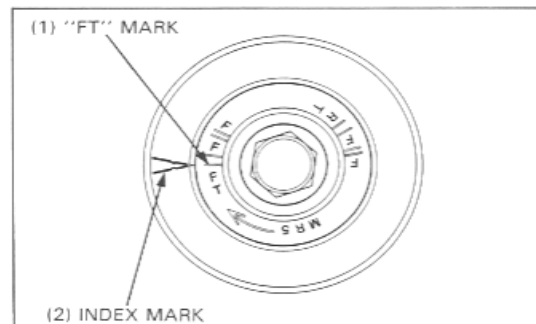

## Cylinder Head/Cylinder/Piston

Install the camshaft on the cylinder head through the cam chain and install the cam sprocket on the camshaft with the timing marks (index line) facing the outside.

### NOTE

- The camshafts are identified by marks on their flanges.  
"F": Front cylinder camshaft  
"R": Rear cylinder camshaft

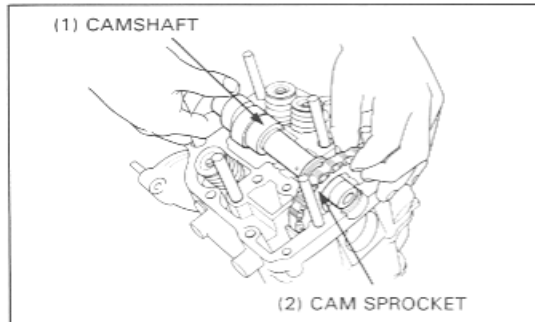

Place the camshaft into its correct position with the "F" mark on the flange facing up.

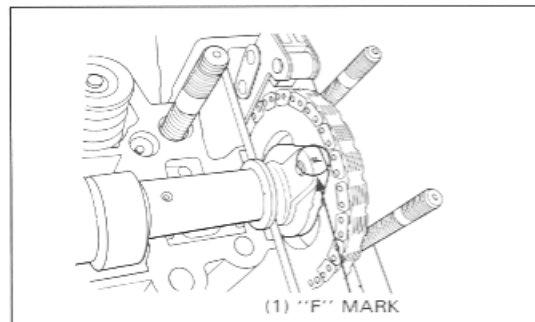

Align the timing marks (index line) on the cam sprocket with the top of the cylinder head and place the cam chain on the sprocket.

Install the cam sprocket on the camshaft flange and recheck that the timing marks (index lines) align with the top of the cylinder head.

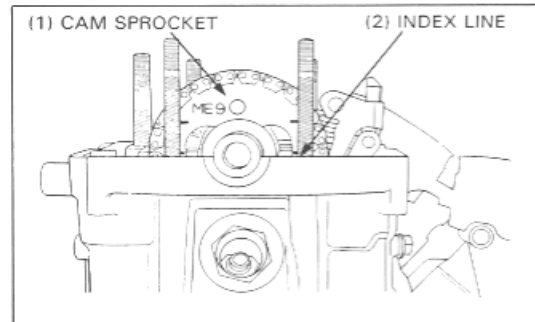

### NOTE

- Apply a locking agent to the sprocket bolt threads.

Align the cam sprocket bolt holes in the cam sprocket and camshaft, install and tighten the cam sprocket bolt finger tight.

Turn the crankshaft clockwise 360°, install the other cam sprocket bolt and tighten it to the specified torque.

**Torque: 18 N·m (1.8 kg·m, 13 ft·lb)**

Turn the crankshaft clockwise 360° and tighten the other cam sprocket bolt to the specified torque.

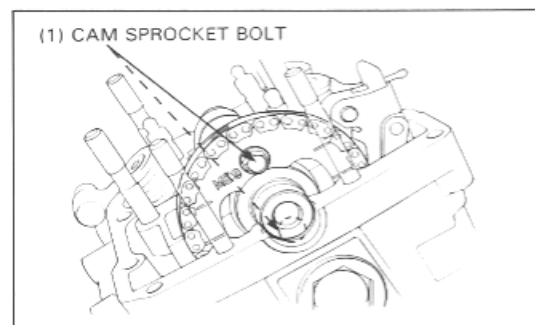

## 8-12

Apply molybdenum disulfide oil to the spark plug sleeve threads and O-ring groove.  
Place the new O-ring into the spark plug sleeve collar groove.  
Install the sleeve using the special tool.

**5 TOOL**

Fork tube holder attachment      07930-KA50100

Torque: 13 N-m (1.3 kg-m, 9 ft-lb)

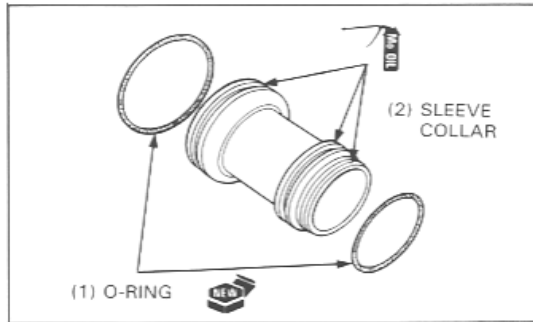

**Rear Cylinder Camshaft Installation**

Turn the crankshaft clockwise and align the "FT" mark on the primary drive gear with the index mark on the right crankcase cover.

Make sure the "F" mark on the front camshaft is facing UP.

If the "F" mark is facing down (cannot be seen), turn the crankshaft clockwise one revolution so that the "F" mark on the front camshaft is facing UP.

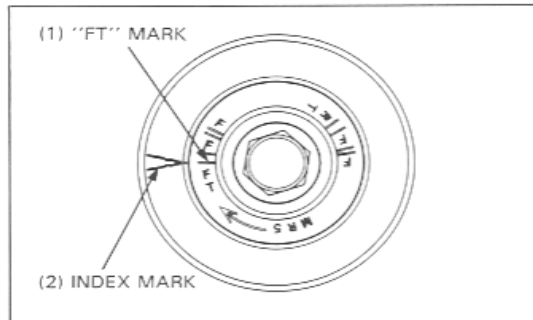

Next turn the crankshaft clockwise approximately 5/8 turn until the "RT" mark on the primary drive gear and the index mark on the right crankcase cover align.

The remainder of the rear cylinder camshaft installation is the same as the procedures described on page 8-12 except the mark on the camshaft flange that should face up should be an "R".

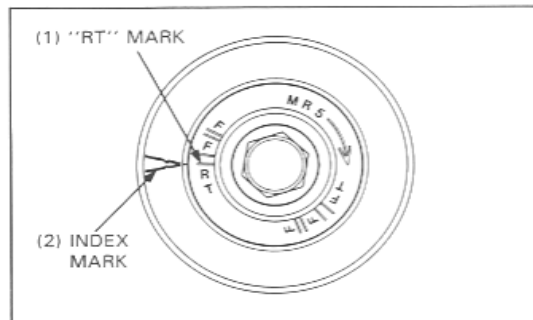

**Installing Both Camshaft**

Turn the crankshaft clockwise and align the "FT" mark on the primary drive gear with the index mark on the right crankcase cover.

Install the front camshaft with the "F" mark on the camshaft facing UP.

Then follow each of the detailed instructions on page 8-12.

Next turn the crankshaft clockwise approximately 5/8 turn until the "RT" mark on the primary drive gear and the index mark on the right crankcase cover.

Install the rear camshaft with the "R" mark on the rear camshaft facing UP.

Then follow each of the detailed instructions on page 8-12 except the mark on the camshaft flange that should face up should be an "R".

# Cylinder Head Disassembly/Assembly

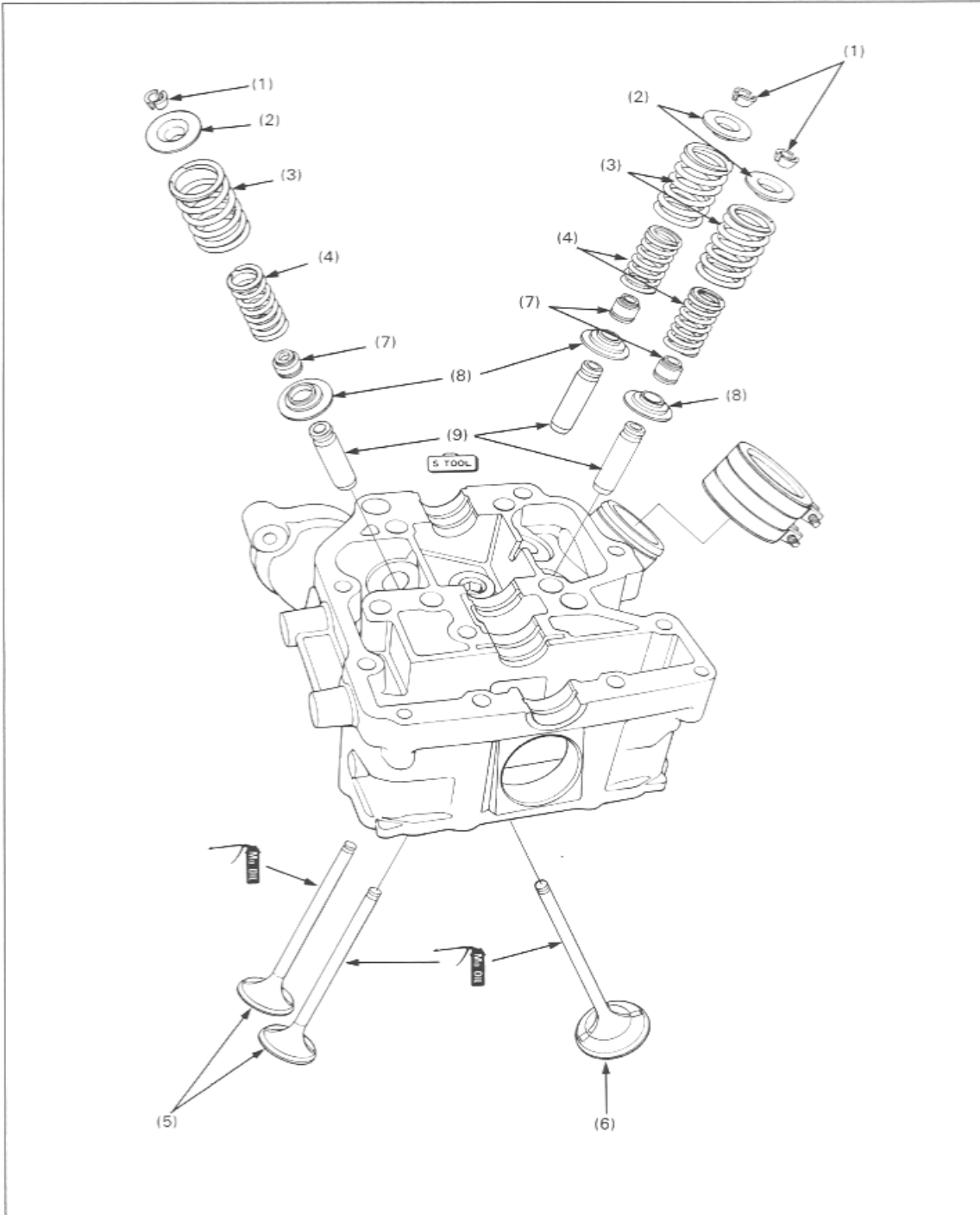

## NOTE

- Mark all parts during disassembly so they can be placed back their original position.
- Remove carbon deposits from the combustion chamber and clean off the head gasket surface before assembly.
  - Avoid damaging the gasket surface.
  - Gaskets will come off easier if soaked in solvent.
- Valve guide replacement see section 9 of the Common Service Manual.

## Requisite Service

- Cylinder head removal/installation (page 8-8)

Procedure		Q'ty	Remarks
(1)	<b>Disassembly Order</b> Valve spring cotter	6	Assembly is in the reverse order of disassembly. NOTE • To prevent loss of tension, do not compress the valve spring more than necessary.
(2)	Retainer	3	NOTE • Select the proper retainer for the compressor to prevent any contact with the head.
(3)	Outer valve spring	3	NOTE • Exhaust outer spring are paint coated green. • The tightly wound coils of the intake valves outer springs should face in toward the combustion chamber.
(4)	Inner valve spring	3	NOTE • Before installation, lubricate each valve stem with molybdenum disulfide oil and insert the valve into the valve guide. • To avoid damage to stem seal, turn the valve slowly when inserting.
(5)	Inlet valve	2	
(6)	Exhaust valve	1	
(7)	Valve stem seal	3	
(8)	Valve spring seat	3	
(9)	Valve guide	3	

# Cylinder, Piston Removal/Installation

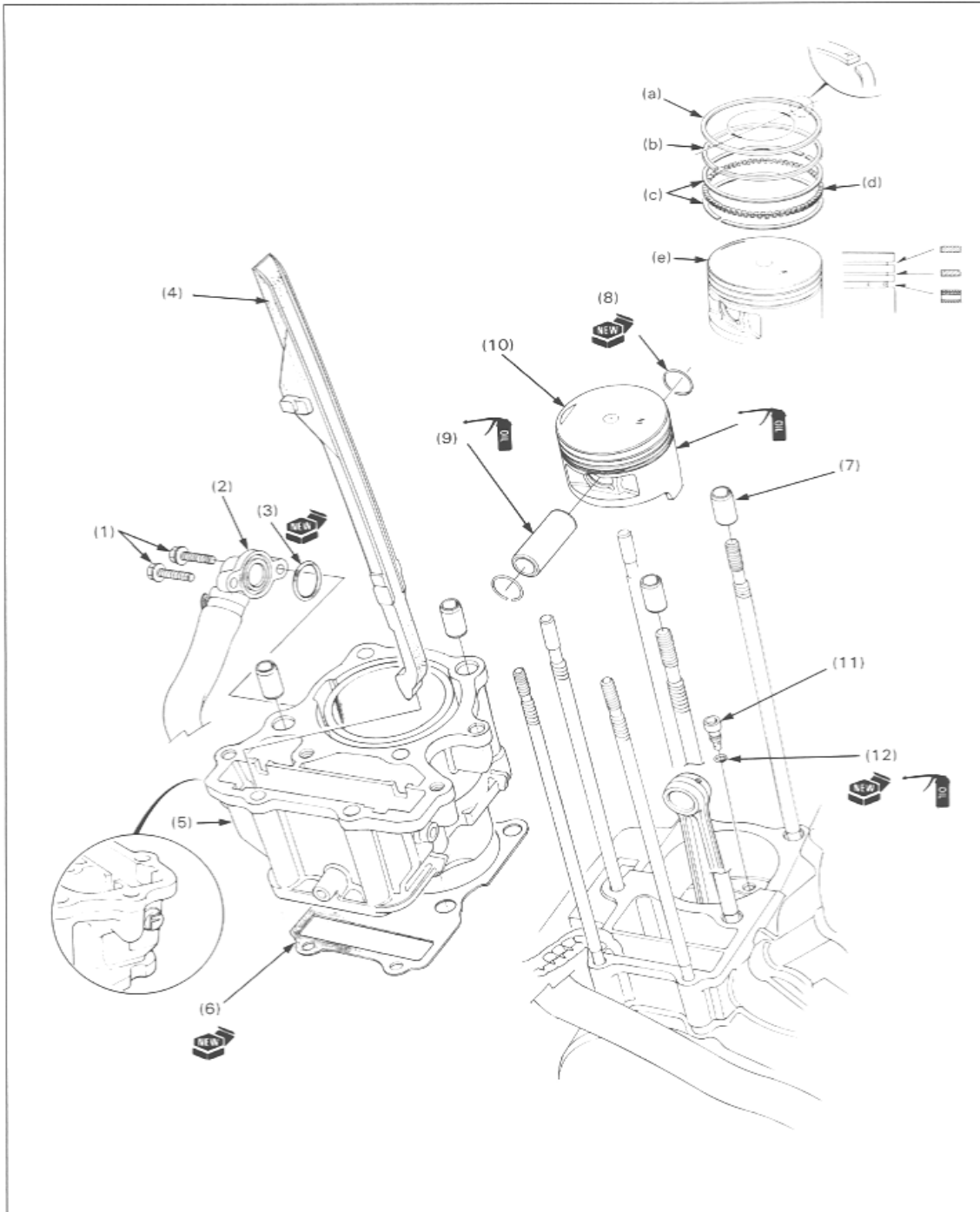

## Requisite Service

- Cylinder head removal/installation (page 8-8)

Procedure	Q'ty	Remarks
<b>Removal Order</b>		Installation is in the reverse order of removal.
(1) Water joint mounting bolt	2	
(2) Water joint	1	
(3) O-ring	1	
(4) Cam chain guide	1	
(5) Cylinder	1	
(6) Gasket	1	
(7) Dowel pin	2	
(8) Piston pin clip	2	NOTE • Place the shop towel over the crankcase opening to prevent piston pin clips from falling into the crankcase.
(9) Piston pin	1	
(10) Piston assembly	1	NOTE • Install the piston with the IN mark facing towards the intake side.
<b>Piston Ring Removal Order</b>		Installation is in the reverse order of removal.
(a) Top ring	1	NOTE
(b) Second ring	1	• Use care when removing or installing the rings.
(c) Side rail	2	• Insert the outside surface of the ring into the proper ring groove and roll the ring around the groove to make sure that the ring has a free fit around the piston's circumference.
(d) Spacer	1	
(e) Piston	1	
(11) Oil jet	1	
(12) O-ring	1	

## Cylinder Head/Cylinder/Piston

### Cylinder Stud Bolt Replacement

If you will replace the stud bolts, remove the stud bolt from the crankcase.

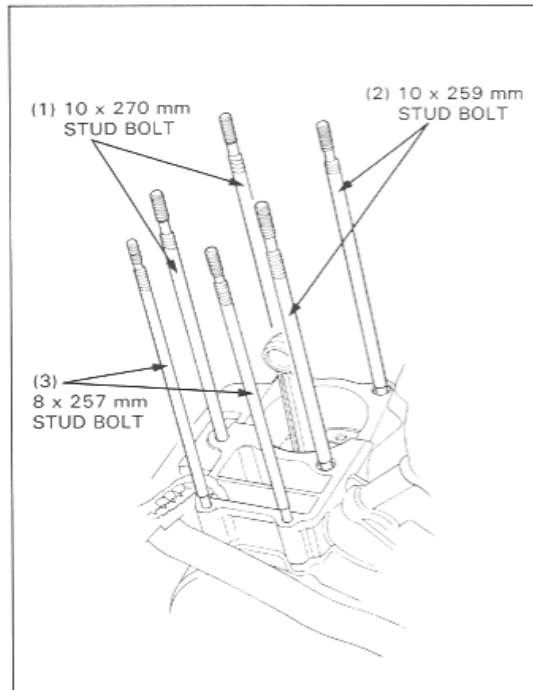

Install the new stud bolts.

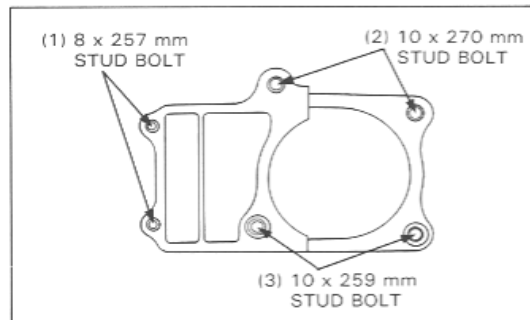

After installing, be sure to measure the distance from the top of each stud to the crankcase surface as shown.

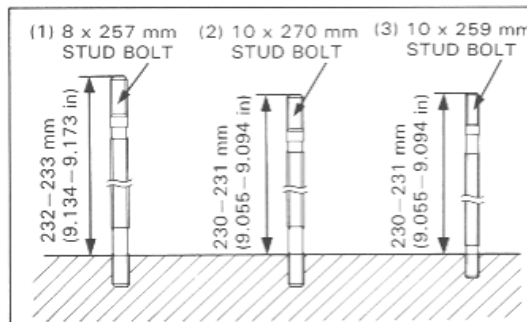

---

## 9. Clutch/Gearshift Linkage

Service Information	9-1	Right Crankcase Cover Removal/ Installation	9-5
Troubleshooting	9-1	Clutch, Primary Drive Gear Removal/ Installation	9-6
Clutch Master Cylinder Removal/ Disassembly	9-2	Gearshift Linkage Removal/ Installation	9-10
Clutch Slave Cylinder Removal/ Installation	9-4		

### Service Information

- This section covers removal and installation of the clutch hydraulic system, clutch, primary drive gear and gearshift linkage.
- DOT 4 brake fluid is used for the hydraulic clutch and is referred to as clutch fluid in this section. Do not use other types of fluid as they are not compatible.
- Clutch maintenance can be done with the engine installed in the frame.
- Gearshift spindle and stopper arms can be serviced with the engine in the frame.
- If the shift forks, drum and transmission require servicing, remove the engine and separate the crankcase (Section 10).

9

### Troubleshooting

#### Clutch:

##### Clutch Lever Soft or Spongy

- Air bubbles in hydraulic system
- Low fluid level
- Leaking hydraulic system

##### Clutch Slips

- Sticking hydraulic system
- Worn discs
- Weak spring
- Faulty clutch hydraulic system
- Additive in engine/transmission oil

##### Motorcycle Creeps with Clutch Disengaged

- Air bubbles in hydraulic system
- Low fluid level
- Leaking lifter hydraulic system
- Sticking lifter hydraulic system
- Warped plates

#### Gearshift Linkage:

##### Hard to Shift

- Air in the clutch lifter hydraulic system
- Shift fork bent
- Shift claw bent
- Shift drum cam grooves damaged
- Leak in the clutch lifter hydraulic system

##### Clutch Lever Pull Too Hard

- Sticking master cylinder piston
- Sticking slave cylinder piston
- Clogged hydraulic system

##### Clutch will Not Disengage

- Air bubbles in hydraulic system
- Low fluid level
- Leaking lifter hydraulic system
- Sticking lifter hydraulic system
- Warped plates

##### Clutch Operation Feels Rough

- Rough outer drum slots
- Sticking master cylinder piston
- Sticking slave cylinder piston

##### Transmission Jumps Out of Gear

- Gear dogs worn
- Shift shaft bent
- Shift drum stopper broken
- Shift forks bent

# Clutch Master Cylinder Removal/Disassembly

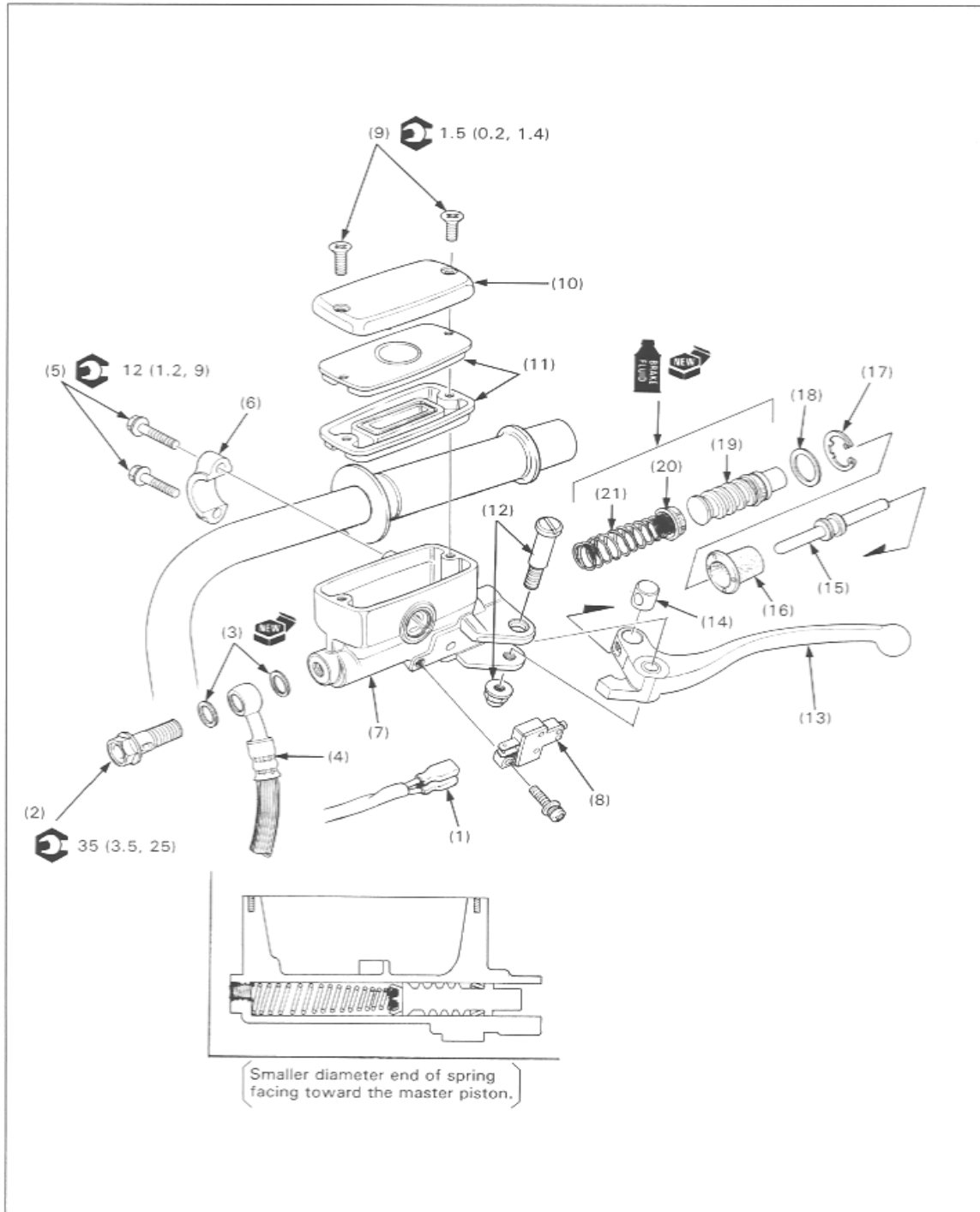

**CAUTION**

- Avoid spilling fluid on painted, plastic, or rubber parts. Place a rag over these parts whenever the system is serviced.
- When removing the oil bolt, cover the end of the clutch hose to prevent contamination.  
Do not allow the foreign material to enter the system.
- Handle the master piston, spring, primary cup and secondary cup as a set.
- Do not allow the lips of the cups to turn inside and be certain the snap ring is firmly seated in the groove.

**NOTE**

- Use only DOT 4 brake fluid from a sealed container.

**Requisite Service**

- Handlebar covers removal/installation (Section 2)
- Clutch fluid draining

Procedure	Q'ty	Remarks
<b>Removal Order</b>		Installation is in the reverse order of removal.
(1) Clutch switch cords	2	
(2) Oil bolt	1	
(3) Sealing washer	2	
(4) Clutch hose	1	
(5) Master cylinder holder bolt	2	Tighten the upper bolt first.
(6) Master cylinder holder	1	NOTE • Install the holder with the "UP" mark facing up.
(7) Clutch master cylinder assembly	1	NOTE • Align the edge of the master cylinder with the punch mark on the handlebar.
<b>Disassembly Order</b>		Assembly is in the reverse order of disassembly.
(8) Clutch switch	1	
(9) Screw	2	
(10) Diaphragm cover	1	
(11) Set plate/diaphragm	1/1	
(12) Clutch lever pivot bolt/nut	1/1	
(13) Clutch lever	1	
(14) Push rod end piece	1	
(15) Push rod	1	
(16) Boot	1	NOTE
(17) Snap ring	1	• Must be replaced as a set.
(18) Washer	1	
(19) Master piston	1	
(20) Primary cup	1	
(21) Spring	1	

## Clutch Slave Cylinder Removal/Installation

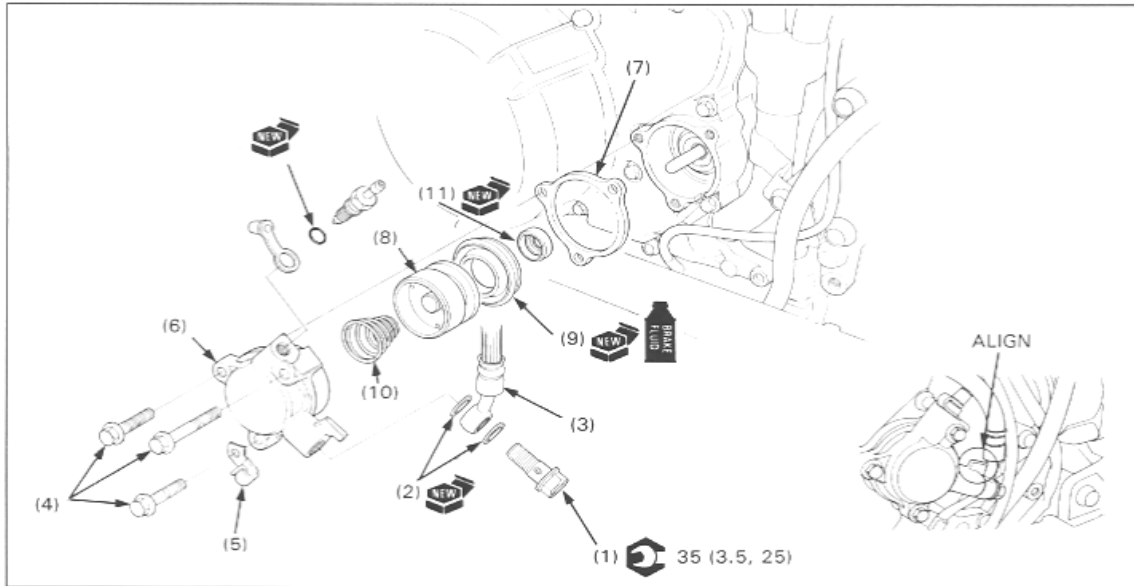

### CAUTION

- Avoid spilling fluid on painted, plastic, or rubber parts. Place a rag over these parts whenever the system is serviced.
- When removing the oil bolt, cover the end of the clutch hose to prevent contamination.

### NOTE

- Use only DOT 4 brake fluid from a sealed container.

### Requisite Service

- Sub-frame removal/installation (page 7-4)
- Clutch fluid draining

Procedure	Q'ty	Remarks
<b>Removal Order</b>		Installation is in the reverse order of removal.
(1) Oil bolt	1	
(2) Sealing washer	2	
(3) Oil hose	1	
(4) Flange bolt	3	
(5) Wire clamp ('89 only)	1	
(6) Slave cylinder assembly	1	Apply clean grease to the clutch lifter rod end.
(7) Insulator	1	
<b>Disassembly Order</b>		<b>NOTE</b>
(8) Slave cylinder piston	1	• If piston removal is difficult, apply compressed air to the fluid inlet to remove the piston.
(9) Piston seal	1	Clean the piston groove with clean clutch fluid.
(10) Spring	1	
(11) Oil seal	1	

## Right Crankcase Cover Removal/Installation

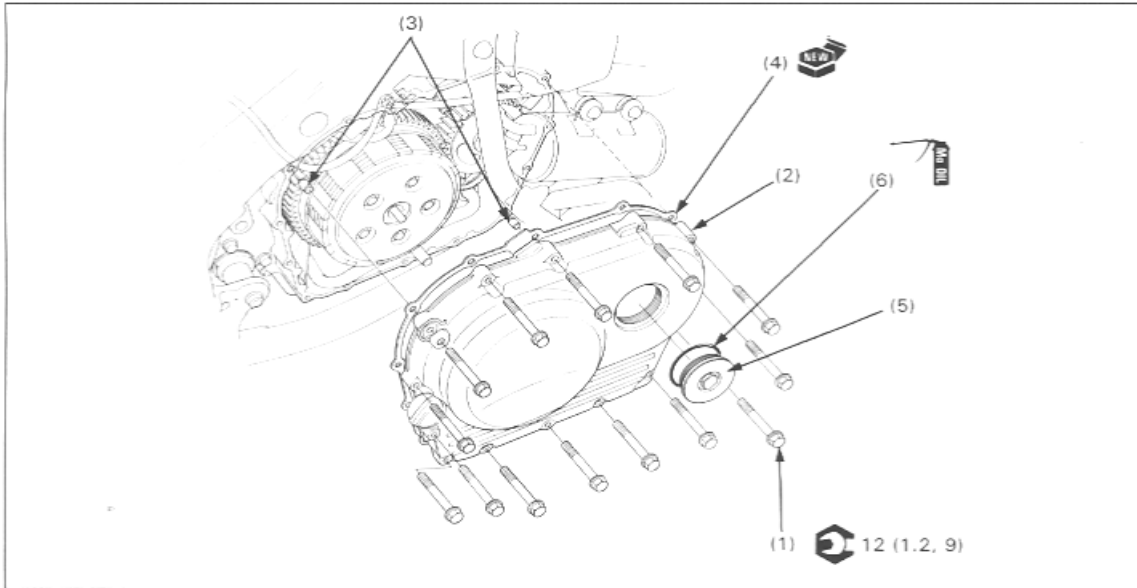

### Requisite Service

- Right lower cover removal/installation (Section 2)
- Engine oil draining

Procedure	Q'ty	Remarks
<b>Removal Order</b>		Installation is in the reverse order of removal.
(1) Flange bolt	14	Tighten the bolts in a crisscross pattern in 2 to 3 steps.
(2) Right crankcase cover	1	
(3) Dowel pin	2	
(4) Gasket	1	
(5) Timing hole cap	1	
(6) O-ring	1	Replace the new one, if desired.

### Clutch, Primary Drive Gear Removal/Installation

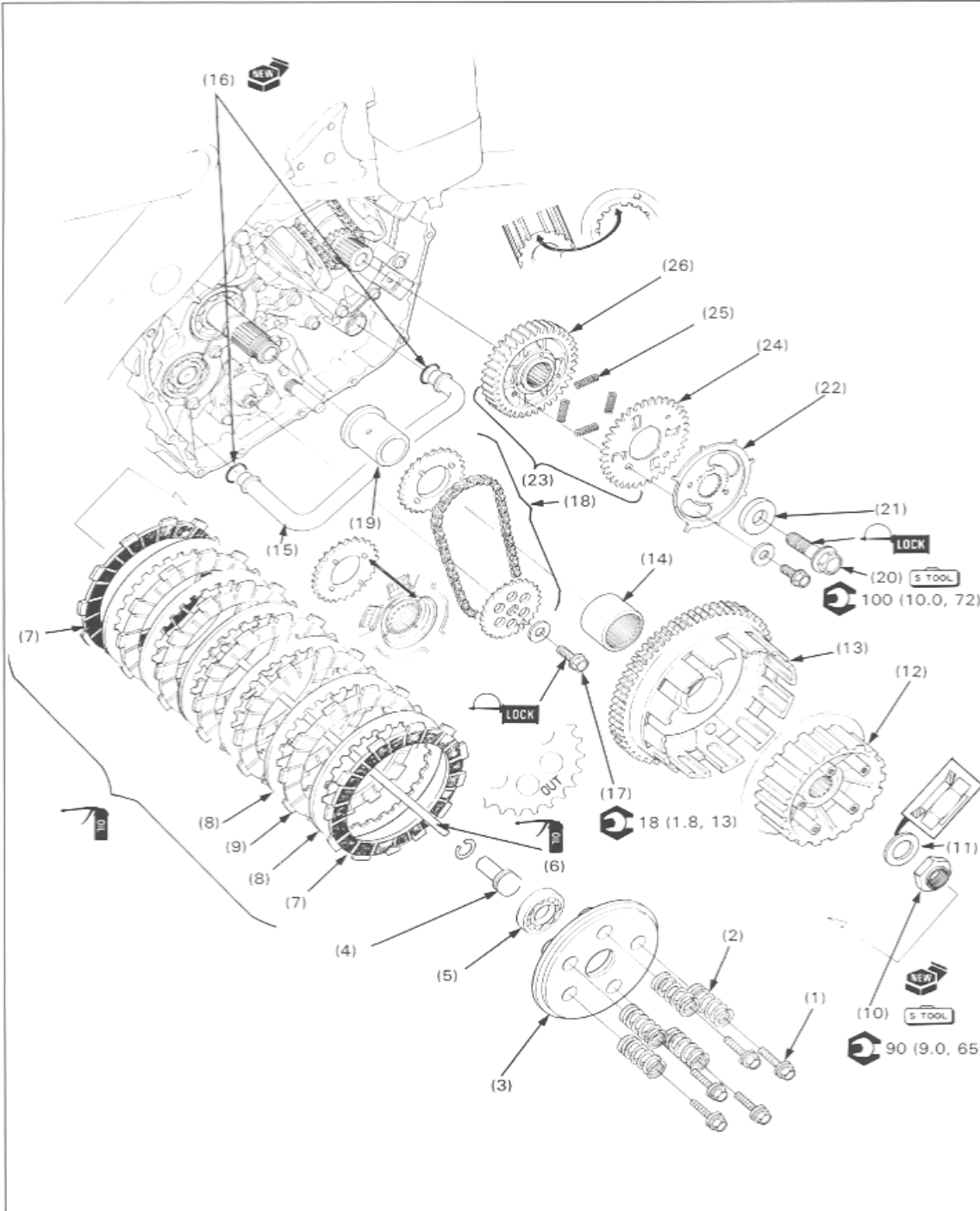

## NOTE

- The clutch assembly does not have removed, for primary drive gear removal and installation.

## Requisite Service

- Right crankcase cover removal/installation (page 9-5)

Procedure		Q'ty	Remarks
(1)	<b>Clutch Removal Order</b> Clutch lifter bolt/washer	5	Installation is in the reverse order of removal. NOTE • Loosen or tighten the bolts in a crisscross pattern in 2 or 3 steps.  NOTE • Apply 2 or 3 drops of clean engine oil into the rod. Coat with clean engine oil them.  (See page 9-8). Install the lock washer with its dished face towards the inside.  At installation, turn the oil pump drive chain and align the holes with the oil pump drive gear bosses.
(2)	Clutch spring	5	
(3)	Lifter plate	1	
(4)	Lifter guide	1	
(5)	Lifter bearing	1	
(6)	Lifter rod	1	
(7)	Clutch disc A	2	
(8)	Clutch plate	6	
(9)	Clutch disc B	5	
(10)	Clutch center lock nut	1	
(11)	Lock washer	1	
(12)	Pressure plate	1	
(13)	Clutch outer	1	
(14)	Needle bearing	1	
(15)	Oil pipe	1	
(16)	O-ring	2	
(17)	Oil pump driven gear bolt	1	
(18)	Drive/driven gear, drive chain assembly	1	
(19)	Clutch outer guide	1	
(20)	<b>Primary Drive Gear Removal Order</b> Primary drive gear bolt	1	Installation is in the reverse order of removal. NOTE • Aligning the primary gear and sub-gear teeth (anti-backlash gear) with a screw driver, and secure them with a suitable 6 mm bolt (page 9-9). • After installation remove the 6 mm bolt.  NOTE • Align the wide groove in the ignition pulse generator plate with the wide tooth on the crankshaft and install the ignition pulse generator plate.  At replacement, replace as an assembly.
(21)	Plain washer	1	
(22)	Ignition pulse generator	1	
(23)	Primary drive gear	1	
(24)	Primary drive sub-gear	1	
(25)	Spring	4	
(26)	Primary drive gear	1	

## Clutch/Gearshift Linkage

### Clutch Center Lock Nut Removal/Installation

#### Removal

Remove the clutch discs and plate (page 9-6).

Unstake the clutch center lock nut with a drill or grinder.  
Hold the clutch center with the clutch center holder.

 S TOOL

Clutch center holder

07923—MB00000  
equivalent commercially  
available in U.S.A.

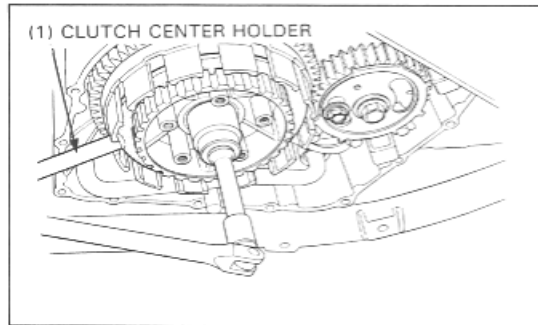

If the engine is out of the frame, remove the clutch center lock nut following this procedure.

- Unstake the clutch center lock nut with a drill or grinder.
- Hold the output shaft with the shaft holder.
- Shift the transmission into 5th gear.

 S TOOL

Shaft holder

07923—6890101

Remove and discard the clutch center lock nut.

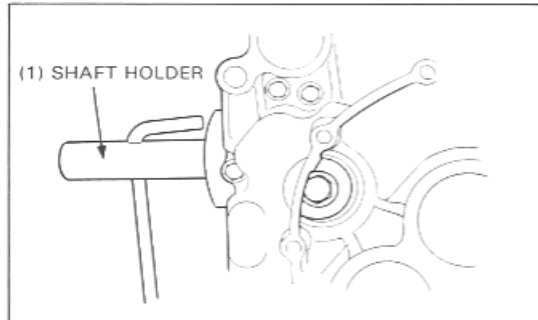

#### Installation

Install the clutch outer and clutch center.

Hold the clutch center with the clutch center holder.

 S TOOL

Clutch center holder

07923—MB00000  
equivalent commercially  
available in U.S.A.

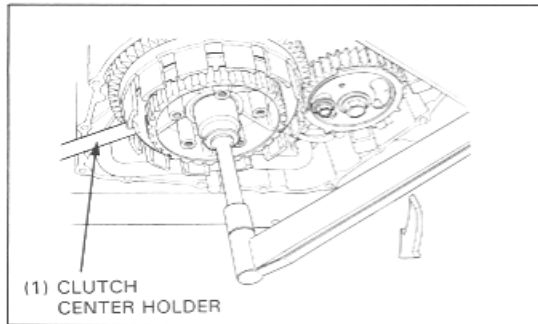

If the engine is out of the frame, shift the transmission into 5th gear and hold the output driven shaft with a shaft holder.

 S TOOL

Shaft holder

07923—6890101

Install the lock washer with its dished face towards the inside.  
Install a new lock nut and tighten the lock nut to specified torque.

Torque: 110 N·m (11.0 kg·m, 79 ft·lb)

Stake the lock nut.

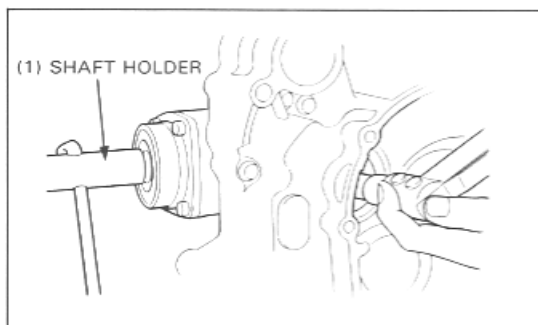

**Primary Drive Gear Bolt Removal/Installation**

## NOTE

- The clutch assembly does not have to be removed.

Align the primary drive gear and sub-gear teeth (anti-backlash gear) with a slotted head screwdriver, and lock them with suitable 6 mm bolt.

## &lt;Except U.S.A.&gt;

Hold the primary drive gear by placing a gear holder between the primary drive and driven gear.

Remove the primary drive gear bolt.



Gear holder

07724-0010100

Not available in U.S.A.

Apply a locking agent to the primary drive gear bolt threads. Install and tighten the primary drive gear bolt.

Torque: 100 N·m (10.0 kg·m, 72 ft·lb)



Gear holder

07724-0010100

Not available in U.S.A.

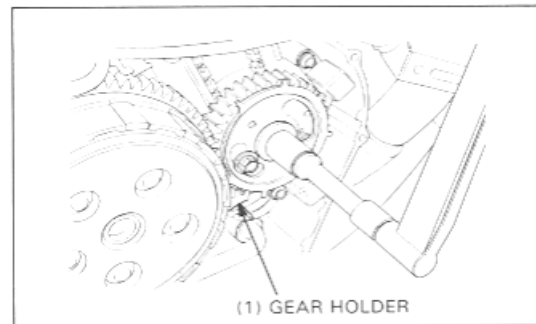
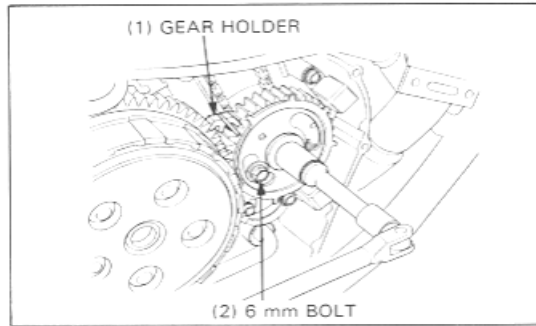

## &lt;U.S.A. Only&gt;

Hold the primary drive gear with the primary gear holder as shown.



Primary gear holder

07924-MC70002

Remove the primary drive gear bolt.

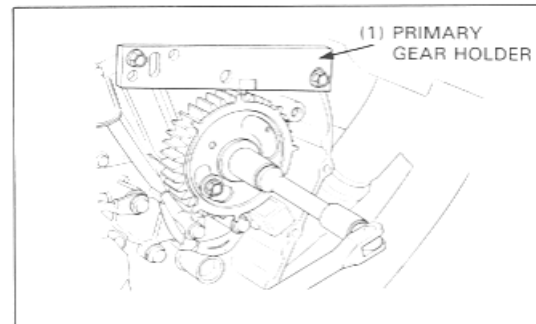

Installation is in the reverse order of removal.

## NOTE

- Apply a locking agent to the primary drive gear bolt threads.

Torque: 100 N·m (10.0 kg·m, 72 ft·lb)

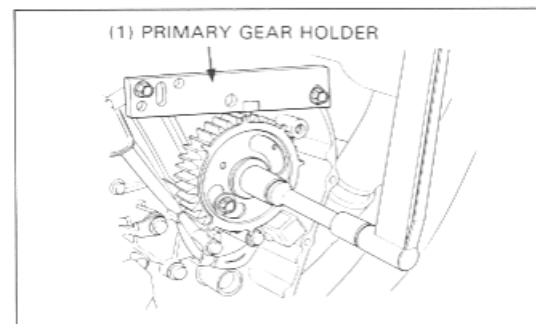

## Gearshift Linkage Removal/Installation

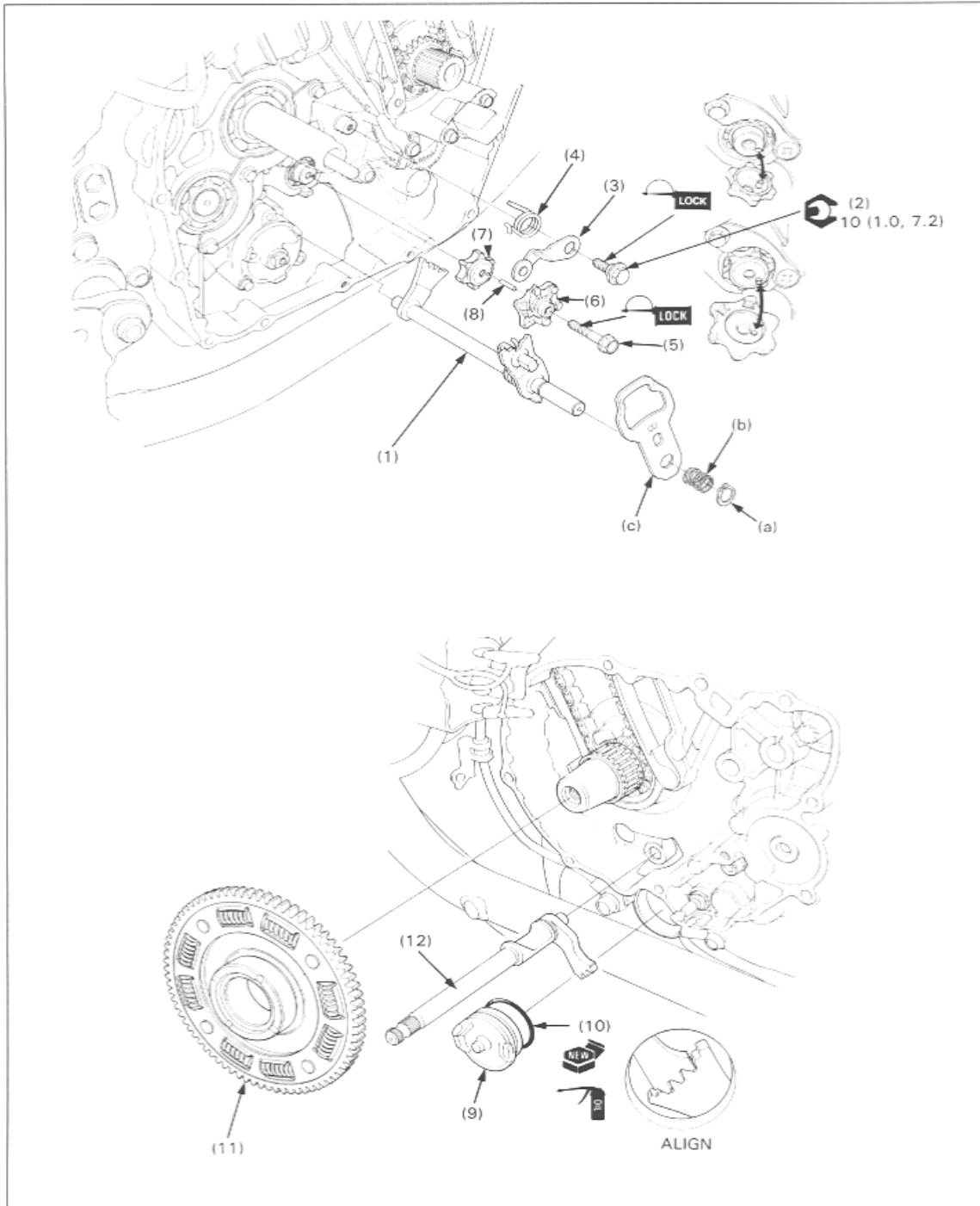

## Requisite Service

- Clutch removal/installation (page 9-6)
- Flywheel removal/installation (page 15-8)
- Oil pump drive sprocket removal/installation (page 9-6)

Procedure		Q'ty	Remarks
<b>Removal Order</b>			
(1)	Gearshift spindle B	1	
(a)	Snap ring	1	
(b)	Spring	1	
(c)	Gearshift spindle plate	1	
(2)	Stopper arm bolt	1	
(3)	Stopper arm	1	
(4)	Return spring	1	
(5)	Shifter cam plate bolt	1	
(6)	Shifter cam plate	1	
(7)	Shift drum center	1	
(8)	Dowel pin	1	
(9)	Shift spindle guide plug	1	
(10)	O-ring	1	
(11)	Starter driven gear	1	Remove the starter driven gear with the gearshift spindle A.
(12)	Gearshift spindle A	1	
<b>Installation Order</b>			
(12)	Gearshift spindle A	1	Install the gearshift spindle A with the starter driven gear.
(11)	Starter driven gear	1	
(1)	Gearshift spindle B	1	NOTE • Align the teeth of the gearshift spindles A and B as shown.
(c)	Gearshift spindle plate	1	
(b)	Spring	1	
(a)	Snap ring	1	
(8)	Dowel pin	1	Install into the shift drum.
(7)	Shift drum center	1	Align the hole with the dowel pin.
(6)	Shifter cam plate	1	Align the hole with the dowel pin.
(5)	Shifter cam plate bolt	1	Apply a locking agent to the threads.
(4)	Return spring	1	
(3)	Stopper arm	1	
(2)	Stopper arm bolt	1	NOTE • Screw the stopper arm bolt in half way. Hook the return spring to the stopper arm and rest the stopper arm on the cam plate, then screw the bolt all the way in and tighten. • After installation, rotate the gearshift spindle and check the shift mechanism for smooth operation.
(10)	O-ring	1	Use a new O-ring and coat it with oil.
(9)	Shift spindle guide plug	1	

---

# 10. Crankshaft/Transmission

Service Information	10-1	Transmission Disassembly/Assembly	10-12
Troubleshooting	10-1	Output Gear Case Removal/ Installation	10-14
Crankcase Separation/Assembly	10-2	Output Gear Case Disassembly/ Assembly	10-18
Connecting Rod Removal/Installation	10-5		
Transmission Removal/Installation	10-10		

## Service Information

- The crankcase must be separated for crankshaft and transmission repair.
- The following parts must be removed before disassembling the crankcase.
  - Oil pump (page 4-3)
  - Clutch and primary drive gear (page 9-6)
  - Gearshift linkage (page 9-10)
  - Starter motor (page 17-4)
  - Water pump (page 6-3)
  - Flywheel and starter clutch (page 17-8)
  - Cylinder head, cylinder, piston (Section 8)
- At crankshaft removal and installation, do not damage the crankshaft main bearings.
- All bearing inserts are select fitted and are identified by color code. Select replacement bearings from the code tables. After installing new bearings, recheck them with plastigauge to verify clearance.
- Apply molybdenum disulfide oil to the main journals and crankpins during assembly.
- When replacing the following output gear components, a new adjustment shims must be selected.
  - Output gear case.
  - Output gear assembly.
  - Output gear bearing.
  - Output gear bearing holder
- Replace the final drive and output drive gear shafts as a set.
- When using the lock nut wrench, use a deflecting beam type torque wrench 20 inches long. The lock nut wrench increase the torque wrench's leverage, so the torque wrench reading will be less than the torque actually applied to the lock nut. The specification given on the torque values (page 1-14) is the actual torque applied to the lock nut, not the reading on the torque wrench when using the lock nut wrench. The procedure later in the text gives both actual and indicated torque specifications.

**10**

## Troubleshooting

### Excessive Noise

- Crankshaft
  - Worn main bearing
  - Worn rod bearing
- Connecting rod
  - Worn rod small end

### Transmission Jumps Out of Gear

- Gear dogs worn
- Shift shaft bent
- Shift shaft stopper broken
- Shift forks bent

### Hard to Shift

- Air in clutch system
- Shift fork bent
- Shift fork shaft bent
- Shift spindle claw bent
- Shift drum cam grooves damaged
- Shift fork guide pin damaged

### Excessive Output Gear Noise

- Output drive and driven gear worn or damaged
- Bearings worn or damaged
- Excessive backlash between output drive and driven gears
- Improper shim thickness

---

**10-1**

### Crankcase Separation/Assembly

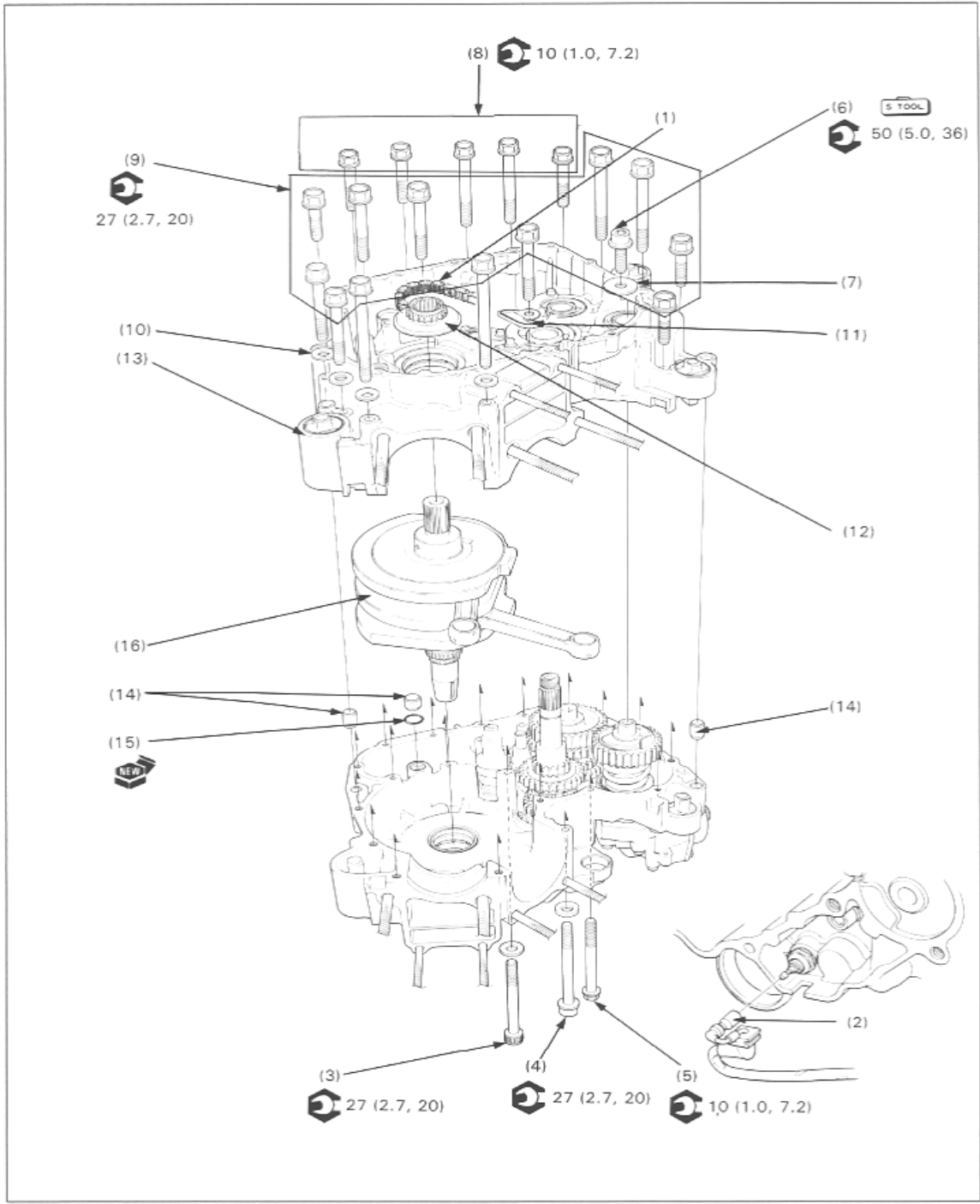

## NOTE

- Refer to Service Information (page 10-1) for removal of necessary parts before separating the crankcase.
- Be careful not to damage the crankshaft main bearings.
- Apply molybdenum disulfide oil to the main journals and crank pins before assembly.

Procedure		Q'ty	Remarks
	<b>Separation Order</b>		Assembly is in the reverse order of separation.
(1)	Rear cylinder cam chain	1	
(2)	Neutral switch connector	1	
(3)	Left crankcase socket bolt/copper washer	1/1	
(4)	socket bolt/plain washer	1/1	
(5)	flange bolt	1	
(6)	Output drive shaft bolt	1	(See page 10-14).
(7)	Washer	1	
(8)	Right crankcase 6 mm bolt	5	Loosen or tighten the 6 mm and 8 mm bolts in a crisscross pattern in 2 or 3 steps.
(9)	Right crankcase 8 mm bolt	12	
(10)	Copper washer	4	
(11)	Ignition pulse generator wire holder	1	
(12)	Rear cylinder cam chain drive sprocket	1	
(13)	Right crankcase	1	Place the crankcase with the left side down.
(14)	Dowel pin	3	
(15)	O-ring	1	
(16)	Crankshaft assembly	1	Connecting rod removal/installation (page 10-5).

## Crankshaft/Transmission

### Crankcase Bolts Installation

Install the right crankcase bolts and washer proper position as shown.  
Tighten the right crankcase bolts in the sequence shown in 2 or 3 steps.

#### Torque:

6 mm bolt: 10 N·m ( 1.0 kg-m, 7.2 ft-lb)  
8 mm bolt: 27 N·m ( 2.7 kg-m, 20 ft-lb)

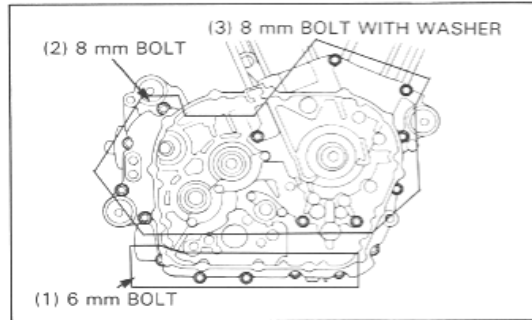

Install the left crankcase bolts and washers as shown.  
Tighten the left crankcase bolts in 2 or 3 steps.

#### Torque:

6 mm bolt: 10 N·m ( 1.0 kg-m, 7.2 ft-lb)  
8 mm bolt: 27 N·m ( 2.7 kg-m, 20 ft-lb)

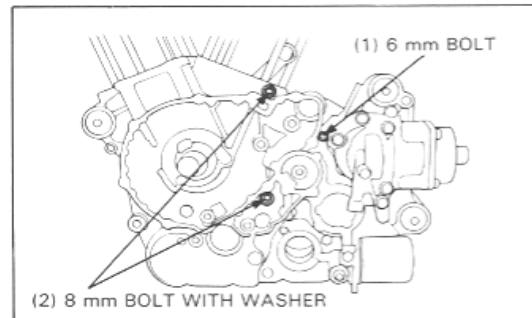

### Output Drive Shaft Bolt Removal/Installation

#### Removal

Hold the final driven shaft with a shaft holder and remove the output drive shaft bolt and washer.



Shaft holder

07923-6890101

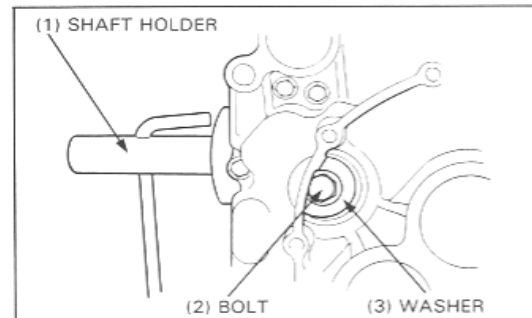

#### Installation

Hold the final driven shaft with the shaft holder. Install the washer and output drive shaft bolt then tighten the bolt.

Torque: 50 N·m (5.0 kg-m, 36 ft-lb)



Shaft holder

07923-6890101

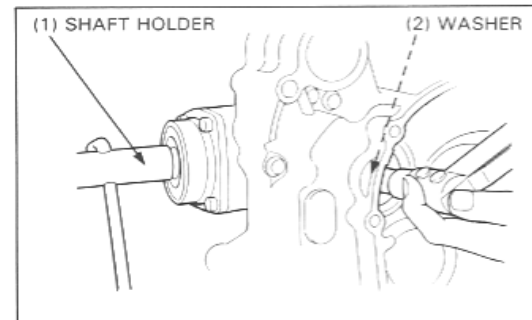

## Connecting Rod Removal/Installation

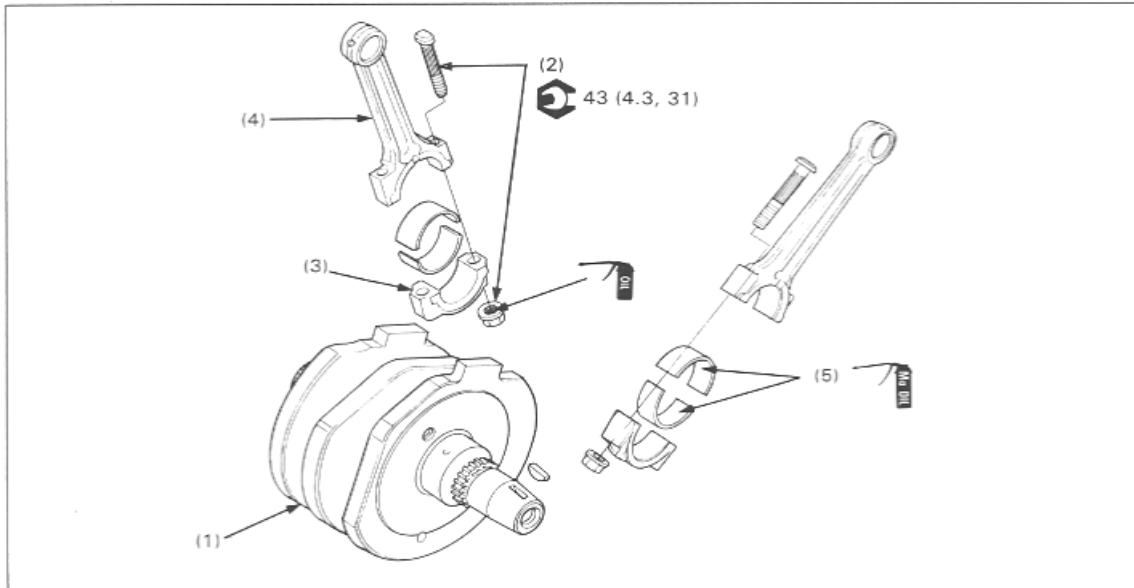

**NOTE**

- Mark all parts during disassembly so they can be replaced in their original position.
- All bearing inserts are select fitted and are identified by color code. Select replacement bearings from the code table (page 10-6). After installing new bearings, recheck them with plastigauge to verify clearance.
- Apply molybdenum disulfide oil to the connecting rod bearing and crankpin.

**Requisite Service**

- Crankcase separation/assembly (page 10-2)

Procedure	Q'ty	Remarks
<b>Removal Order</b>		Installation is in the reverse order of removal.
(1) Crankshaft assembly	1	
(2) Connecting rod bearing cap nut/bolt	4/4	At installation, apply oil to the nuts threads.
(3) Bearing cap	2	NOTE • Tap the side of the cap lightly if it is hard to remove.
(4) Connecting rod	2	
(5) Connecting rod bearing metal	4	Bearing selection (page 10-6).

## Crankshaft/Transmission

### Crankshaft/Crankcase Selection

Crankcase and crankshaft are select fitted.

A number 1 or 2 on each crank weight is the code for the main journal O.D.

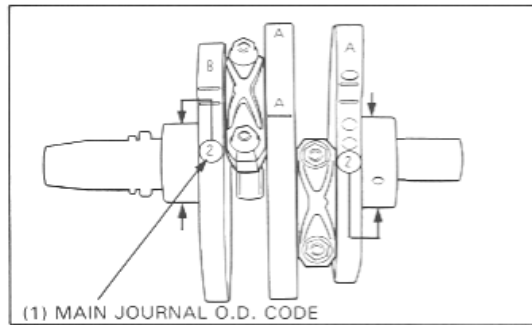

A letter A or B on the crankcase is the code for the crankcase main journal bearing I.D.

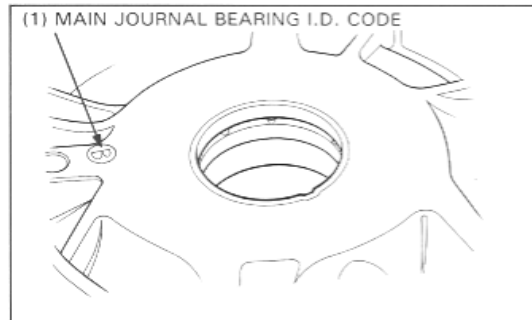

If the crankcase and/or crankshaft are replaced, select them with the following fitting table.

#### NOTE

- The "O" mark in the table indicates that matching is possible in the crossed codes.

### Crankshaft/Crankcase Fitting Table

Unit: mm (in)

Main Journal O.D. Code		1	2
		49.992–50.000 (1.9682–1.9685)	49.984–49.992 (1.9679–1.9682)
Main Journal I.D. Code	A 50.025–50.033 (1.9695–1.9698)	○	×
	B 50.017–50.025 (1.9692–1.9695)	×	○

### Crankshaft Main Bearing Selection/Replacement

Measure the main journal O.D. and record it.

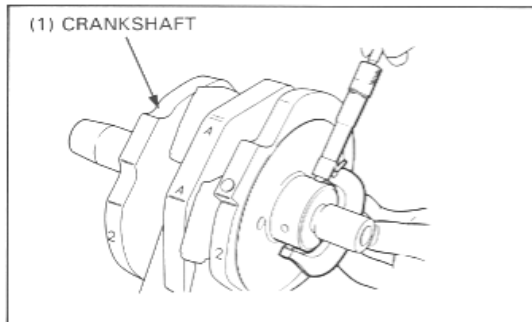

Measure the main journal bearing I.D. and record it.

Calculate the clearance between the main journal and the main bearing.

**Service Limit: 0.060 mm (0.0024 in)**

If the oil clearance is beyond service limit, select the replacement bearings with the procedure that follows.

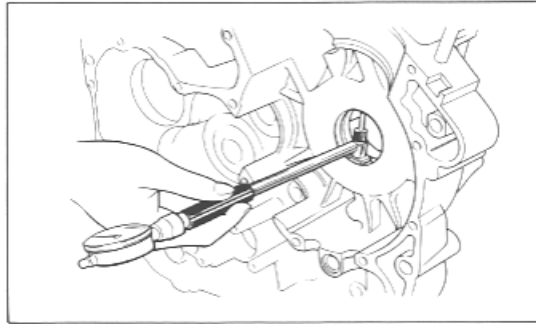

Determine and record the corresponding crankshaft main journal O.D. code.

**NOTE**

- Number 1 or 2 on each crank weight is the code for the main journal O.D.

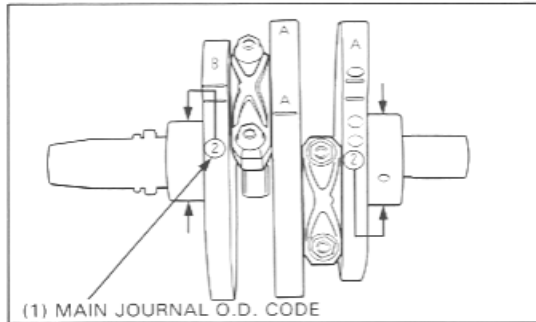

Press the main bearing out of the crankcase using the hydraulic press and special tools.

**NOTE**

- Always use a press to remove the main bearing.

**STOOL**

Driver 07749-0010000  
Main bearing remover attachment 07946-ME90100

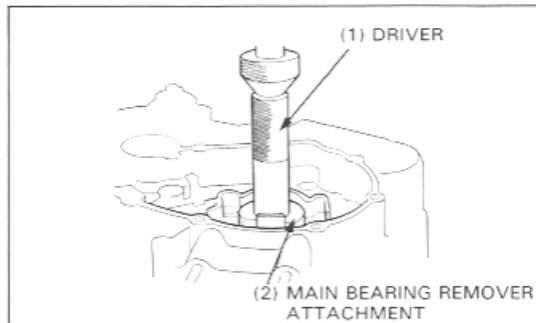

Measure the crankcase I.D. and record it.



## Crankshaft/Transmission

Choose the replacement main bearings in accordance with the table below.

### Main Bearing Selection Table

Unit: mm (in)

Main Journal O.D. Code	1	2
Crankcase I.D. Code	49.992 – 50.000 (1.9682 – 1.9685)	49.984 – 49.992 (1.9679 – 1.9682)
53.970 – 53.980 (2.1248 – 2.1252)	C (BROWN)	B (BLACK)
53.980 – 53.990 (2.1252 – 2.1256)	B (BLACK)	A (BLUE)

Apply molybdenum disulfide oil to the outer surface of the new main bearing.

Align the tab on the bearing with the groove in the crankcase and press the main bearing into the crankcase.

#### CAUTION

- Be careful not to damage the bearings.

#### NOTE

- The marks on both sides of the Main Bearing Driver attachment mean.  
"R": Use for right side bearing  
"L": Use for left side bearing

#### TOOL

Driver

07749-0010000

Main bearing driver attachment

07946-ME90200

#### NOTE

- After installation, check that the bearing oil hole is aligned with the crankcase oil hole.
- If the main journal bearing replaced, delete the main journal bearing I.D. code letter on the crankcase.

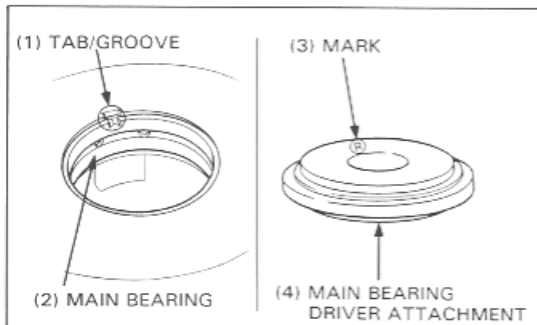
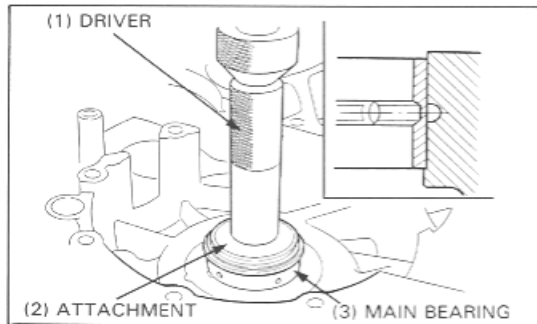
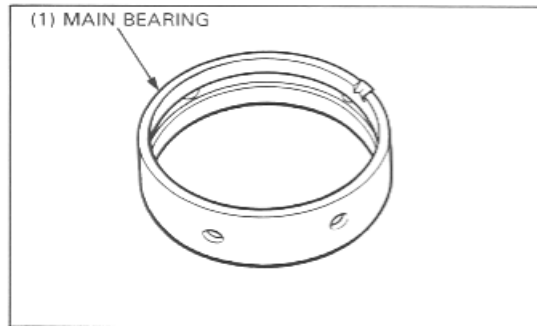

### Connecting Rod Bearing Selection

Inspect the bearing inserts for damage or separation and measure the crankpin oil clearance (see Section 14 of the Common Service Manual).

If the oil clearance is beyond the service limit, select replacement bearings as follows:

Determine and record the corresponding rod I.D. code number.

#### NOTE

- Number 1 or 2 on the connecting rod is the code for the connecting rod.

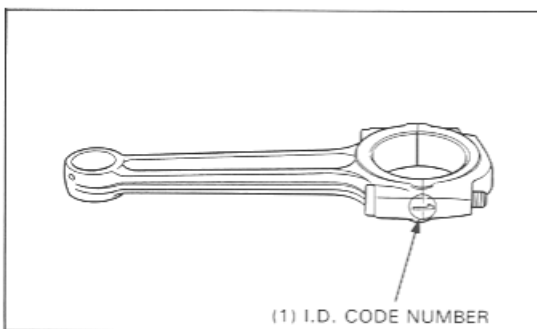

Determine and record the corresponding crankpin O.D. code (or measure the crankpin O.D.)

NOTE

- Letters A or B on each crank weight are the codes used for each crankpin O.D.

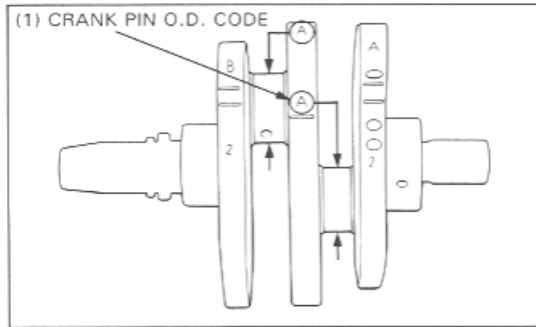

Cross reference the crankpin and connecting rod codes to determine the replacement bearing color.

Connecting Rod Bearing Selection Table

Unit: mm (in)

Crankpin O.D. Code		A	B
Connecting Rod I.D. Code		42.982–42.990 (1.6922–1.6925)	42.974–42.982 (1.6919–1.6922)
1	46.000–46.008 (1.8110–1.8113)	E (YELLOW)	D (GREEN)
2	46.008–46.016 (1.8113–1.8116)	D (GREEN)	C (BROWN)

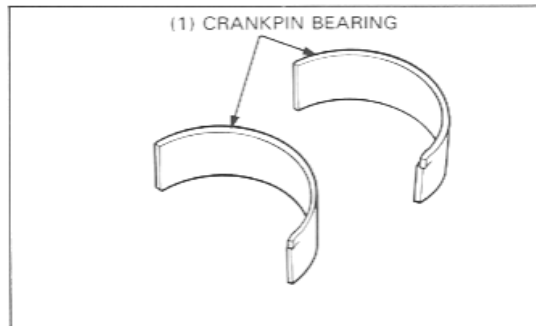

Connecting Rod Selection

The weight code stamped on the connecting rod is an alphabetical code.

When replacing the connecting rod, select the new rod by cross matching the front and rear cylinder connecting rod weights in accordance with the selection table below.

NOTE

- The mark "O" in the table indicates that matching is possible in the crossed codes.

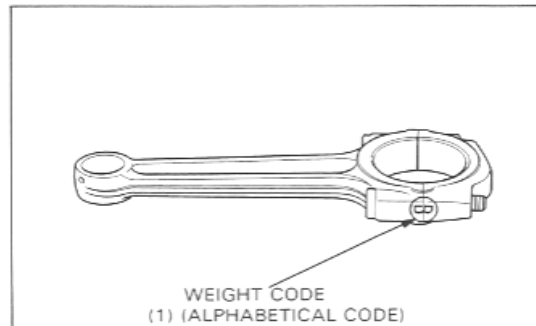

Selection Table

Rear Rod Code \ Front Rod Code	A	B	C	D
A	O	O	x	x
B	O	O	O	x
C	x	O	O	O
D	x	x	O	O

# Transmission Removal/Installation

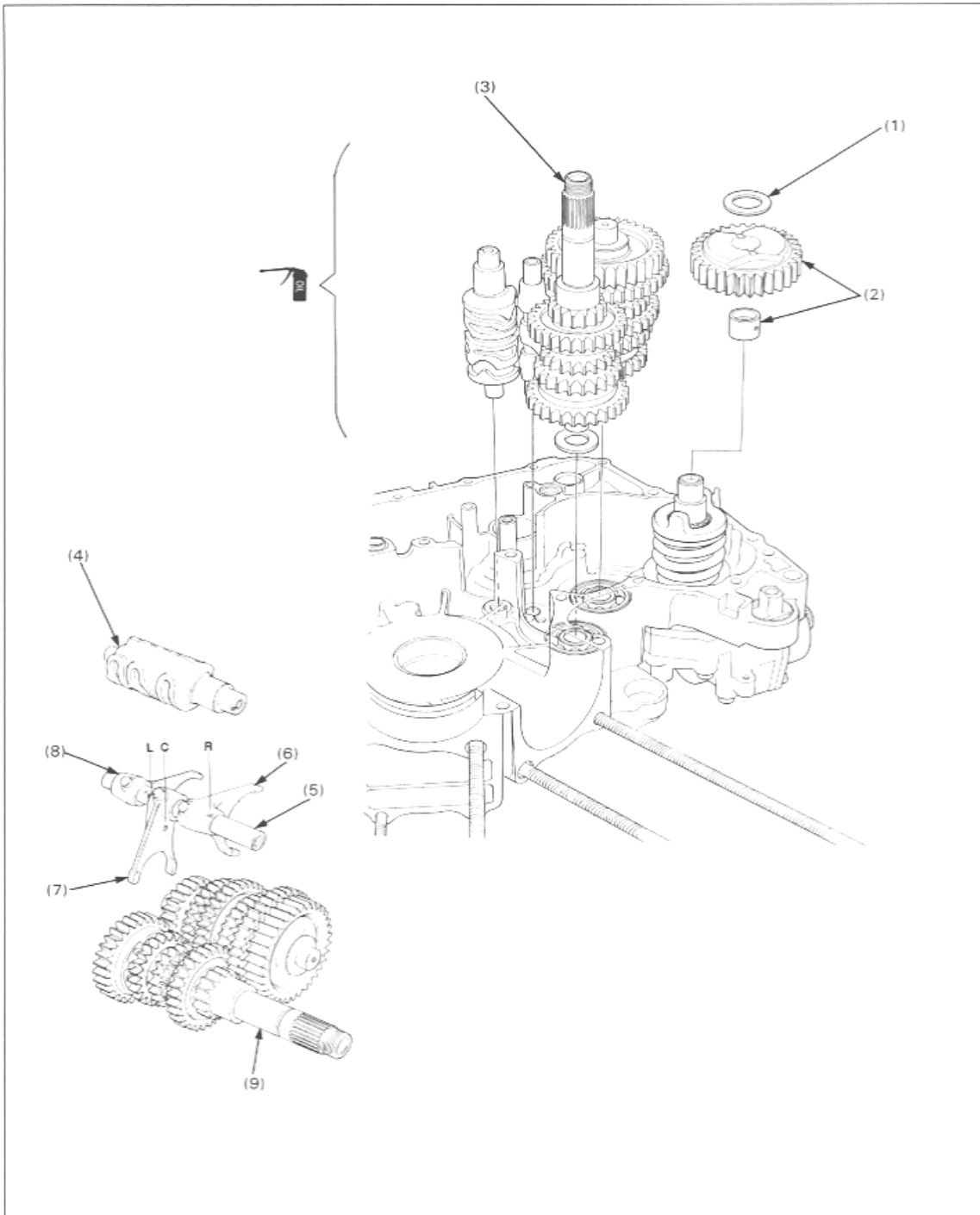

10-10

NOTE

- Turn the mainshaft and countershaft to ensure that the gears turn smoothly after reassembly.
- After installation, lubricate gears with clean recommended engine oil while turning the shaft.

**Requisite Service**

- Crankcase separation/assembly (page 10-2)

Procedure		Q'ty	Remarks
<b>Removal Order</b>			
(1)	Plain washer (27 x 37 x 2)	1	
(2)	Final driven gear/gear bushing	1/1	
(3)	Transmission/shift fork/shift drum assembly	1	
(4)	Shift drum	1	
(5)	Shift fork shaft	1	
(6)	Right shift fork	1	
(7)	Center shift fork	1	
(8)	Left shift fork	1	
(9)	Mainshaft/countershaft assembly	1	
<b>Installation Order</b>			
(9)	Mainshaft/countershaft assembly	1	Secure install the plain washer.
(8)	Left shift fork	1	NOTE
(7)	Center shift fork	1	• Install the forks on its mark facing right.
(6)	Right shift fork	1	• Apply molybdenum disulfide oil to the shifter gear groove.
(5)	Shift fork shaft	1	NOTE
(4)	Shift drum	1	• Install the shaft oil hole facing left crankcase. Aligning the shift fork pin.
(3)	Transmission/shift fork/shift drum assembly	1	NOTE
(2)	Final driven gear/gear bushing	1/1	• Do not forget the plain washer.
(1)	Plain washer	1	• For easy installation, place the left crankcase cylinder stud bolt facing up.

## Transmission Disassembly/Assembly

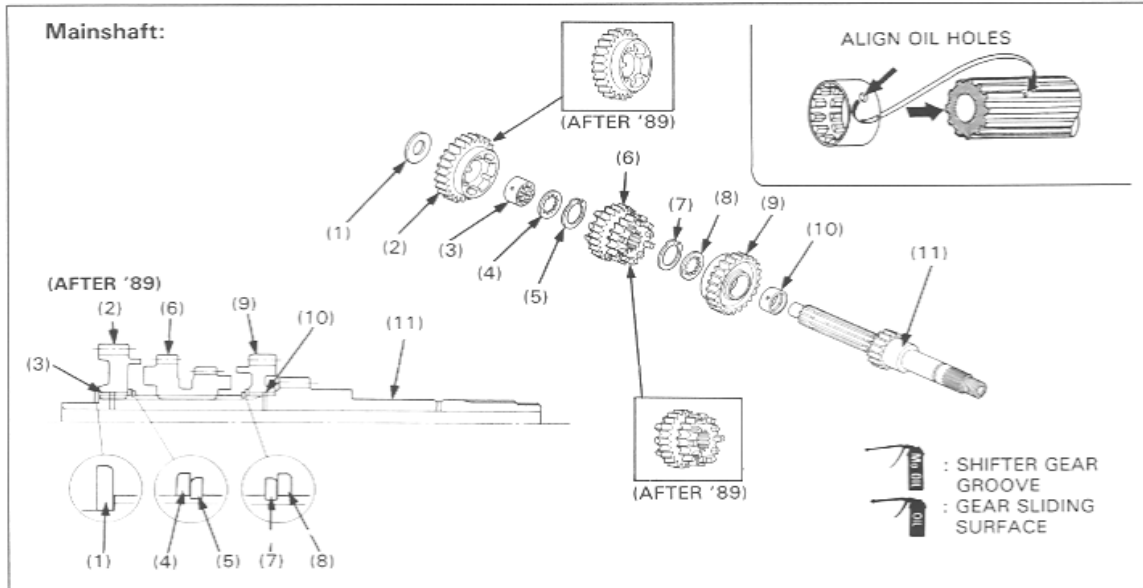

**NOTE**

- When assembling the transmission, apply molybdenum disulfide oil to all sliding surface of the mainshaft, countershaft and bushings to ensure initial lubrication.
- Always install the thrust washers and snap rings with the chamfered (rolled) edge facing away from the thrust load.
- After installing a snap ring, slightly open the ring and rotate it in its groove to be sure it is fully seated.
- Do not use worn snap rings which could easily spin in the groove. They may be too loose to properly seat in the groove.
- Align the gap in the snap ring with the groove of spline.
- Align all oil holes in the bushings with the shaft oil holes.

**Requisite Service**

- Transmission removal/installation (page 10-10)

Procedure	Q'ty	Remarks
<b>Mainshaft Disassembly Order</b>		Assembly is in the reverse order of disassembly.
(1) Washer (20 x 30 x 2)	1	
(2) M5 gear (30T)	1	
(3) M5 gear spline bushing	1	
(4) Spline washer	1	
(5) Snap ring	1	
(6) M2/M3 shifter gear (20/24T)	1	
(7) Snap ring	1	
(8) Spline washer	1	
(9) M4 gear (28T)	1	
(10) M4 gear bushing	1	
(11) Mainshaft/M1 gear (15T)	1	

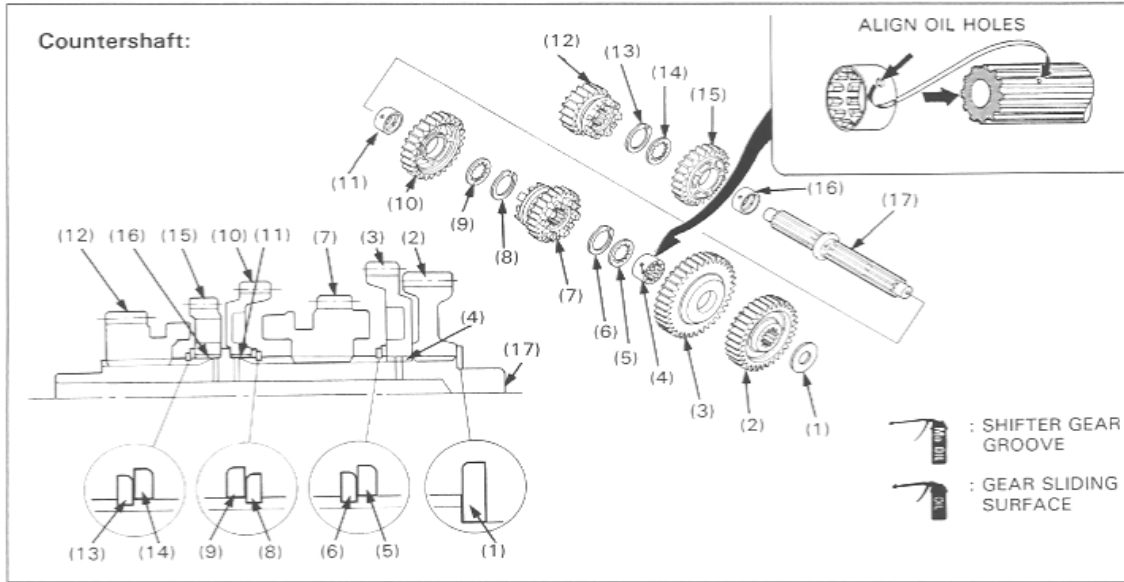

Procedure	Q'ty	Remarks
<b>Countershaft Disassembly Order</b>		Assembly is in the reverse order of disassembly.
(1) Washer (20 x 37 x 2)	1	
(2) Final drive gear (34T)	1	
(3) C1 gear (39T)	1	
(4) C1 gear spline bushing	1	
(5) Spline washer	1	
(6) Snap ring	1	
(7) C4 shifter gear (27T)	1	
(8) Snap ring	1	
(9) Spline washer	1	
(10) C2 gear (34T)	1	
(11) C2 gear bushing	1	
(12) C5 shifter gear (24T)	1	
(13) Snap ring	1	
(14) Spline washer	1	
(15) C3 gear (30T)	1	
(16) C3 gear bushing	1	
(17) Countershaft	1	

## Output Gear Case Removal/Installation

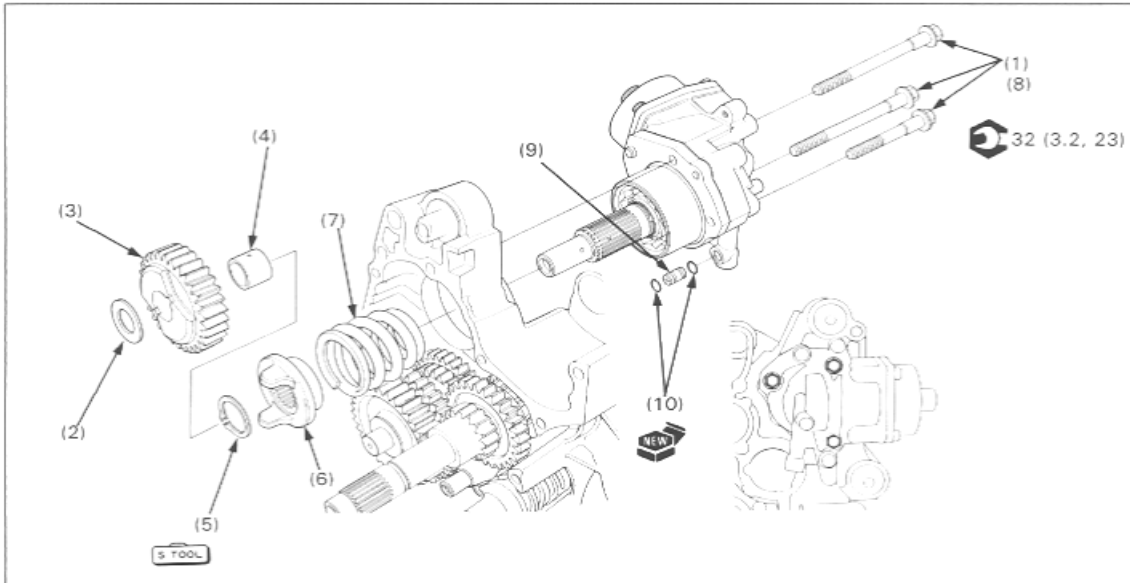

### NOTE

- The following output gear parts can be removed without crankcase separation.
  - Output driven gear and bearing holder
  - Output driven gear bearing holder O-ring

### Requisite Service

- Crankcase separation/assembly (page 10-2)

Procedure	Q'ty	Remarks
<b>Removal Order</b>		
(1) Output gear assembly mounting dowel bolt	3	Installation is in the reverse order of removal. Loosen and separate the crankcase.
(2) Plain washer (20.2 x 35 x 1.8)	1	
(3) Final driven gear	1	
(4) Gear bushing	1	
(5) Snap ring	1	
(6) Damper cam	1	
(7) Damper spring	1	
(8) Output gear assembly mounting dowel bolt	3	(See page 10-15).
(9) Oil olifice	1	
(10) O-ring	1	
		Install the damper spring over the output drive shaft with the closely wound coil facing the crankcase.

**Output Damper Spring Removal/Installation**

(Except U.S.A.)

**Removal**

Install an attachment or equivalent spacer between the compressor bolt and body.  
Place the damper spring compressor onto the damper cam and output drive shaft.

Compress the damper spring by turning the compressor bolt clockwise and remove the snap ring.

Loosen and remove the compressor.

**STOOL**

**Damper spring compressor** 07964—ME90000  
**Snap ring pliers** 07914—5670100  
or equivalent commercially available in U.S.A.

Remove the damper spring.

**Installation**

Install attachment or equivalent spacer between the compressor bolt and body.  
Set the damper spring compressor onto the damper cam and output shaft.

Compress the damper spring by turning the compressor bolt clockwise and install the snap ring.

Remove the compressor.

**STOOL**

**Damper spring compressor** 07964—ME90000  
**Snap ring pliers** 07914—5670100  
or equivalent commercially available in U.S.A.

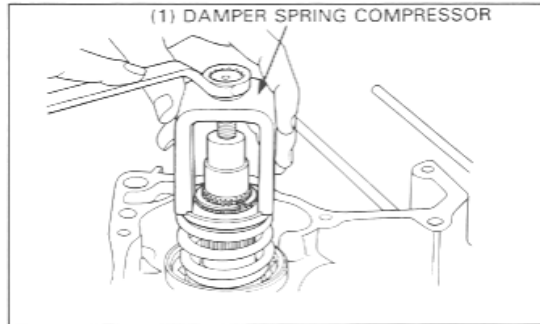
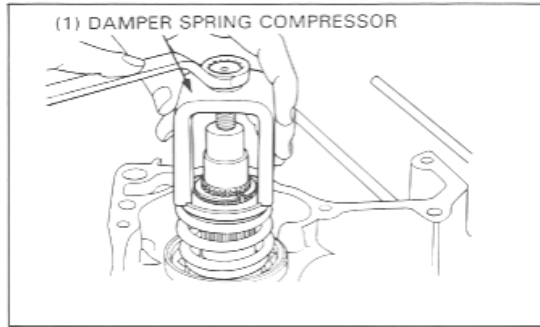

(U.S.A. Only)

**Removal**

Place the threaded adaptor in the end of the output drive shaft and tighten.

Place the compressor seat over the threaded adaptor with the stepped side facing upward.

Install the assembly bolt through the assembly collar and attach it to the threaded adaptor.

Center the compressor seat with the damper lifter then begin to tighten the 24 mm nut of the collar until the snap ring is visible so it can be removed.

**STOOL**

**Assembly bolt** 07965—1660200  
**Assembly collar** 07965—1660300  
**Compressor seat** 07967—9690200  
**Threaded adaptor** 07965—KA30000  
**Snap ring pliers** 07914—5670100  
or equivalent commercially available in U.S.A.

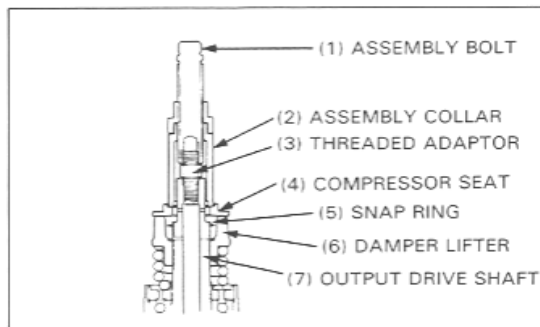

## Crankshaft/Transmission

### Installation

Place the snap ring over the output drive shaft.  
Place the threaded adaptor in the end of the shaft and tighten.  
Place the compressor seat over the threaded adaptor with the stepped side facing upward.  
Install the assembly bolt through the assembly collar and attach it to the threaded adaptor.  
Center the compressor seat with the damper lifter then begin to tighten the 24 mm nut of the collar until the snap ring is visible so it can be installed into the groove in the shaft.

 S TOOL

Assembly bolt	07965-1660200
Assembly collar	07965-1660300
Compressor seat	07967-9690200
Threaded adaptor	07965-KA30000
Snap ring pliers	07914-5670100 or equivalent commercially available in U.S.A.

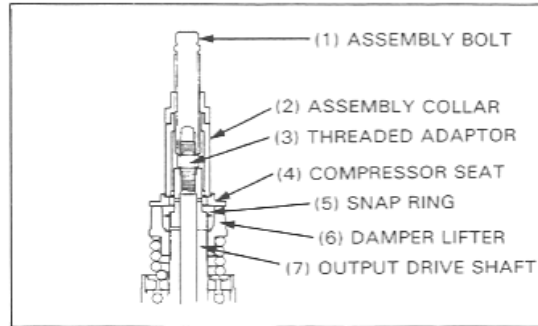

### Backlash Inspection

Place the output gear case in a vise with soft jaws or use a shop towel.  
Set the horizontal type dial indicator on the final drive shaft as shown.  
Hold the driven gear with the shaft holder and rotate the drive shaft until gear slack is taken up.

 S TOOL

Shaft holder 07923-6890101

Turn the drive shaft back and force to read the backlash.

**Service Limit: 0.40 mm (0.0157 in)**

Remove the dial indicator. Turn the output drive shaft 120° and measure the backlash as part of the same procedure.

Repeat this procedure once more, at another 120°.

Compare the difference of the three measurements.

**Difference of Measurements**  
**Service Limit: 0.10 mm (0.004 in)**

If the difference of the measurements exceeds the service limit, it indicates that the bearing is not installed squarely. Inspect the bearings and reinstall if necessary.

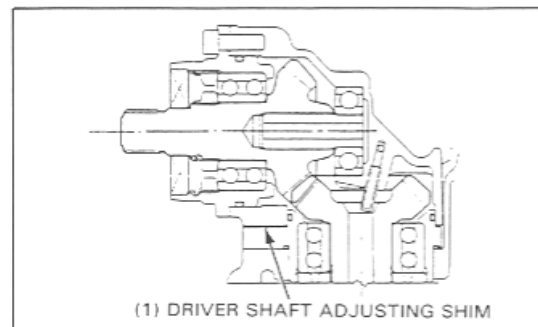
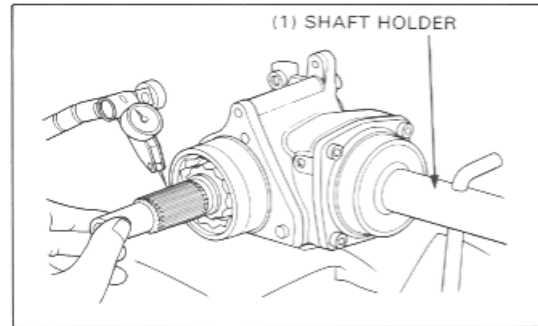

If backlash is excessive, replace the drive shaft adjustment shim with a thinner one.  
If backlash is too small, replace the drive shaft adjustment shim with a thicker one.

Backlash is changed by approximately 0.015 mm (0.0006 in).  
when thickness of the shim is changed by 0.05 mm (0.002 in).

**Output Drive Shaft Adjustment Shims:**

- A: 0.40 mm (0.016 in)
- B: 0.45 mm (0.018 in)
- C: 0.50 mm (0.020 in) — Standard
- D: 0.55 mm (0.022 in)
- E: 0.60 mm (0.024 in)

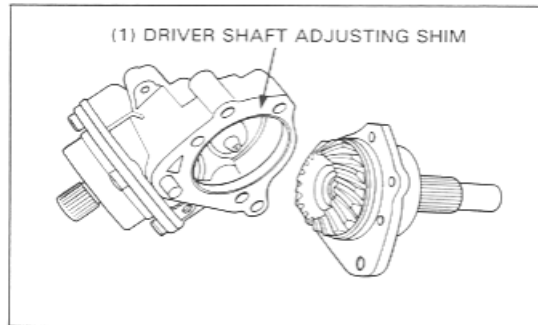

# Output Gear Case Disassembly/Assembly

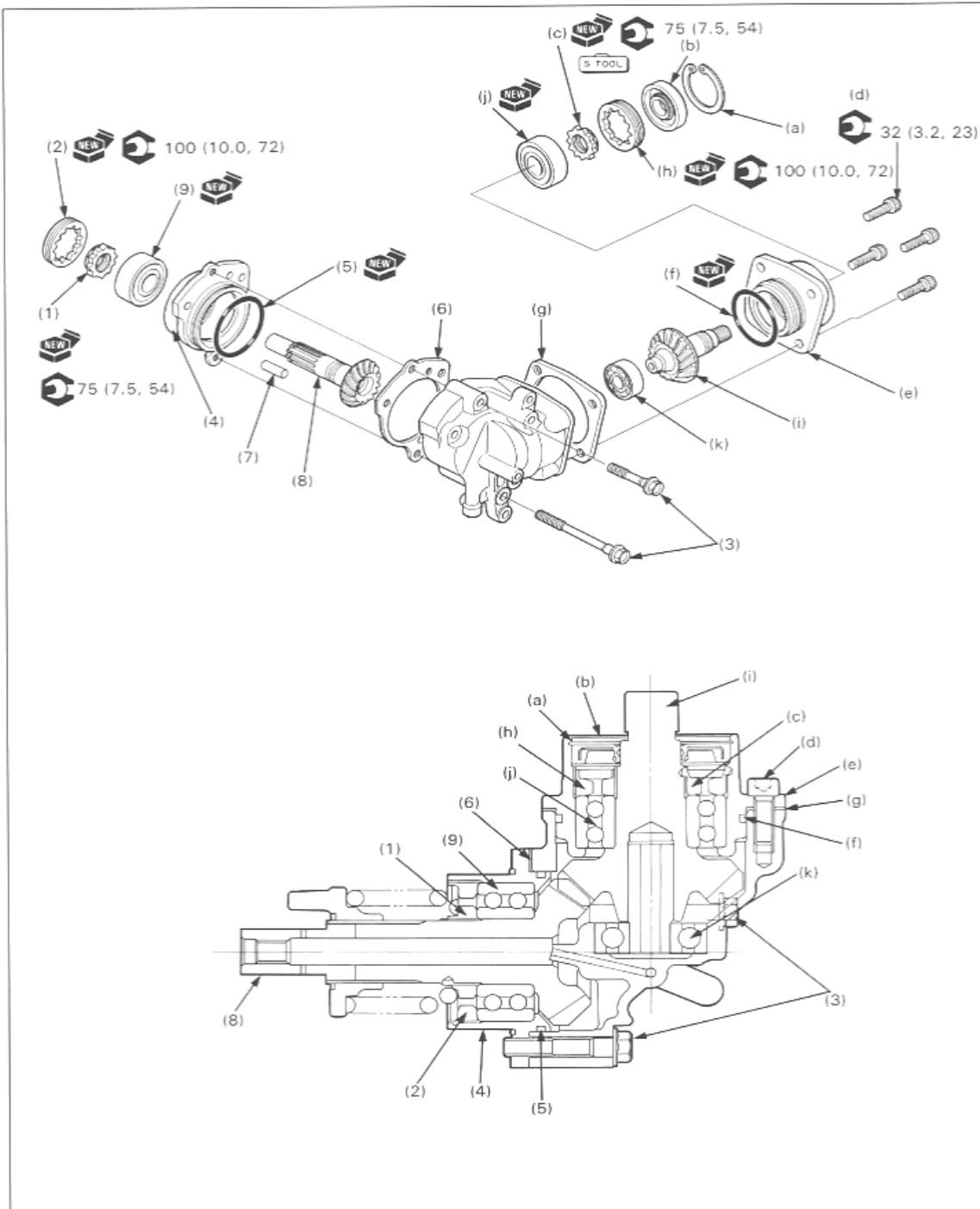

**⚠ WARNING**

- Always wear gloves when handling a heated gear case to prevent burning your hands.

**CAUTION**

- Do not use a torch to heat the output gear case; it may cause warping.

**NOTE**

- When replacing the following output gear components, a new adjustment shim must be selected.
  - Output gear case
  - Output gear bearing
  - Output gear assembly
  - Output gear bearing holder
- Replace the final drive gear and output drive gear as a set.
- When using the lock nut wrench, use a deflecting beam type torque wrench 20 inches long. The lock nut wrench increases the torque wrench's leverage, so the torque wrench reading will be less than the torque actually applied to the lock nut.  
The specification given on the torque values (page 1-14) is the actual torque applied to the lock nut, not the reading on the torque wrench when used with the lock nut wrench. The procedure later in the text gives both actual and indicated.

**Requisite Service**

- Output gear case removal/installation (page 10-14)

Procedure		Q'ty	Remarks
(1)	<b>Output Drive Shaft Bearing Disassembly Order</b> Inner race lock nut	1	Assembly is in the reverse order of disassembly. <b>NOTE</b> • Hold the output drive gear shaft with shaft holder, then remove or install the inner race (see page 10-20).
(2)	Outer race lock nut	1	
(3)	Dowel bolt	2	
(4)	Final drive shaft bearing holder	1	
(5)	O-ring	1	
(6)	Adjustment shim	1	Backlash inspection and shim selection (page 10-16).
(7)	Dowel pin	1	
(8)	Output drive shaft	1	(See page 10-20).
(9)	Output drive shaft bearing	1	(See page 10-20).
(a)	<b>Output Driven Gear Bearing Disassembly Order</b> Snap ring		Assembly is in the reverse order of disassembly.
(b)	Oil seal	1	
(c)	Inner race lock nut	1	<b>NOTE</b> • Hold the output driven gear shaft with shaft holder, then remove the inner race lock nut (page 10-22).
(d)	Bearing holder socket bolt	4	
(e)	Output driven gear bearing holder	1	
(f)	O-ring	1	
(g)	Adjustment shim	1	Shim selection (page 10-25).
(h)	Outer race lock nut	1	(See page 10-23).
(i)	Output driven gear	1	Press out from the bearing holder.
(j)	Output driven gear bearing	1	(See page 10-23).
(k)	Output driven gear case bearing	1	<b>NOTE</b> • Heat the output gear case around the driven gear case bearing 80°C (176°F), then remove the bearing.

## Crankshaft/Transmission

### Output Drive Shaft Bearing Replacement

#### Inner Race Lock Nut Removal

Remove the O-ring.

Place the output gear case in a vise with soft jaws, being careful not to distort it.

Unstake the bearing inner race lock nut with a drill or grinder. Be careful that metal particles do not enter the bearing and that the threads on the shaft are not damaged.

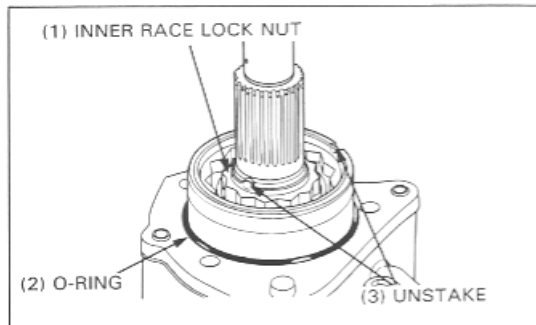

Place the shaft holder on the drive gear shaft, wedging it against the vise to lock the shaft. Remove the bearing inner race lock nut and discard it.

S TOOL

Shaft holder 07923-6890101  
Lock nut wrench, 30 x 64 mm 07916-MB00001

Remove the shaft holder.

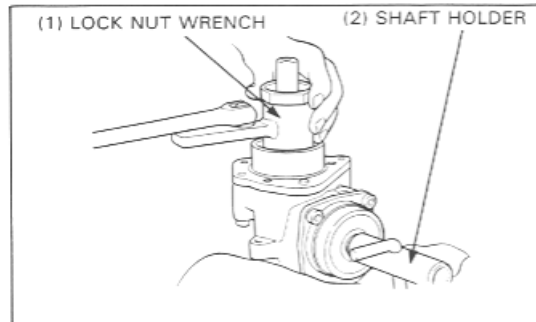

#### Outer Race Lock Nut Removal

Unstake the bearing outer race lock nut with a punch. Remove the bearing outer race lock nut and discard it.

S TOOL

Lock nut wrench, 30 x 64 mm 07916-MB00001

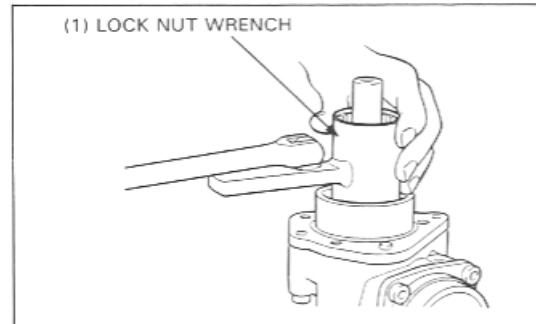

#### Output Drive Shaft Removal

Remove the output drive shaft bearing holder from the output gear case (page 10-18).

Place the output drive shaft and a dis/assembly tool in a hydraulic press.

#### NOTE

- Remove the center guide from the dis/assembly tool before using it.

Press the output drive shaft out of the bearing holder.

S TOOL

Dis/assembly tool 07965-3710101

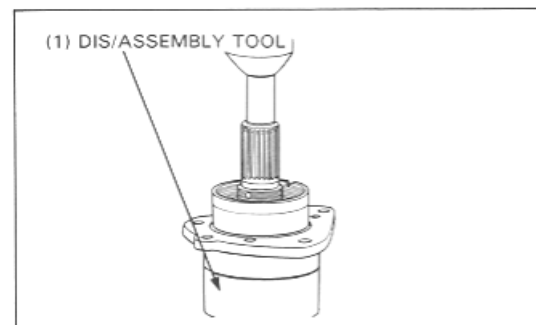

**Bearing Replacement**

Place the bearing holder in a press and remove the bearing.

**S TOOL**

Dis/assembly tool 07965-3710101  
 Driver 07749-0010000  
 Attachment, 42 x 47 mm 07746-0010300  
 Pilot, 30 mm 07746-0040700

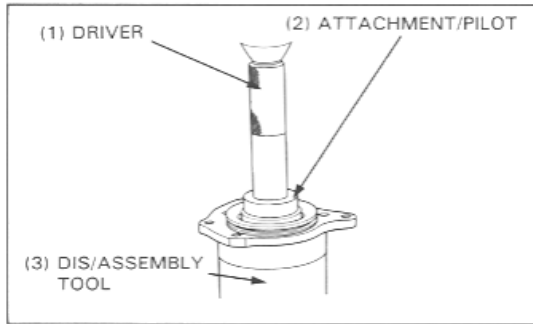

Press a new bearing in the bearing holder.

**S TOOL**

Dis/assembly tool 07965-3710101  
 Driver 07749-0010000  
 Attachment, 62 x 68 mm 07746-0010500  
 Pilot, 30 mm 07746-0040700

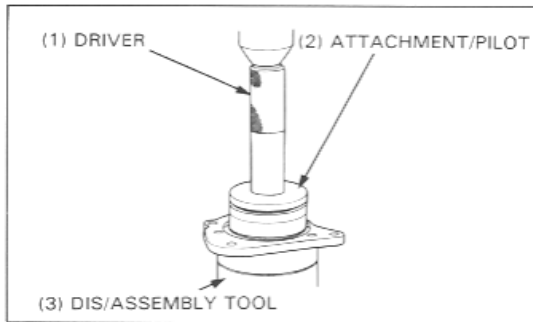

**NOTE**

- If the output drive shaft requires replacement, the drive and driven shaft must be replaced as a set.

Support the bearing inner race and press the output drive shaft in with a pilot.

**NOTE**

- Place the pilot's threaded end into the output drive shaft.

**S TOOL**

Driver, 40 mm I.D. 07746-0030100  
 Attachment, 30 mm I.D. 07746-0030300  
 Pilot, 20 mm 07746-0040500

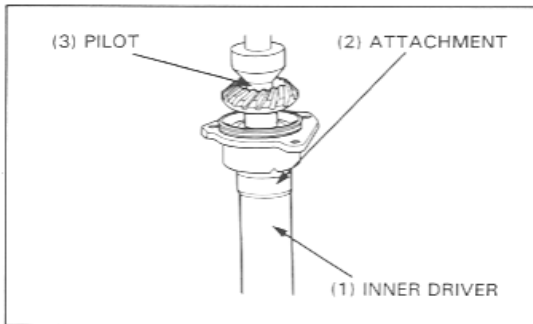

Install the bearing holder onto the gear case (page 10-18).

**Outer Race Lock Nut Installation**

Place the gear case in a vise with a soft jaws and install and tighten a new bearing outer race lock nut.

Torque: 100 N·m (10.0 kg·m, 72 ft·lb)

Torque wrench scale reading: 91 N·m (9.1 kg·m, 65 ft·lb)

**S TOOL**

Lock nut wrench, 30 x 64 mm 07916-MB00001

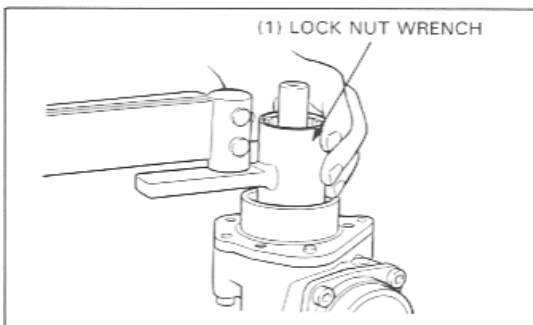

## Crankshaft/Transmission

### Inner Race Lock Nut Installation

Hold the shaft and install and tighten a new bearing inner race lock nut.

Torque: 75 N·m (7.5 kg-m, 54 ft-lb)

Torque wrench scale reading: 69 N·m (6.9 kg-m, 50 ft-lb)

**STOOL**

Shaft holder 07923-6890101  
Lock nut wrench, 30 x 64 mm 07916-MB00001

Remove the shaft holder.

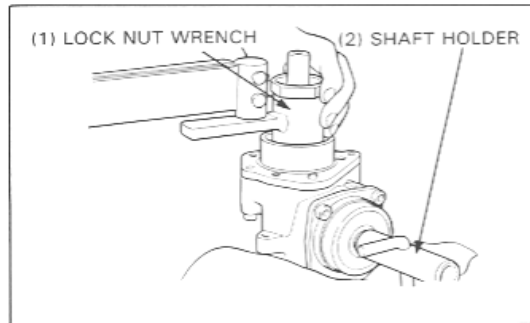

Stake the inner and outer lock nuts.

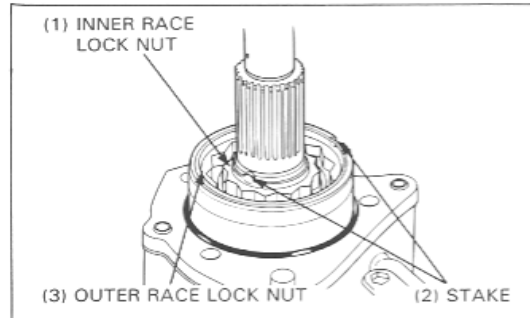

### Output Driven Gear Bearing Replacement

#### Inner Race Lock Nut Removal

Remove the output driven gear oil seal from the driven gear bearing holder (page 10-18).

Ply or drill the staked edge of the driven gear bearing inner race lock nut.

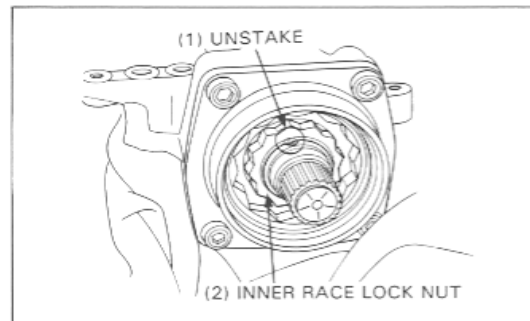

Hold the output driven gear with the shaft holder and remove the inner race lock nut and discard it.

**STOOL**

Shaft holder 07923-6890101  
Lock nut wrench, 30 x 64 mm 07916-MB00001

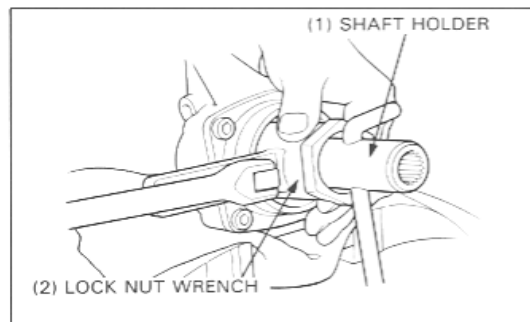

**Outer Race Lock Nut Removal**

Remove the bearing holder mounting bolts and the holder from the output gear case (page 10-18).

Ply or drill the staked edge of the output driven gear bearing outer race lock nut.

Remove the O-ring and shim from the bearing holder.

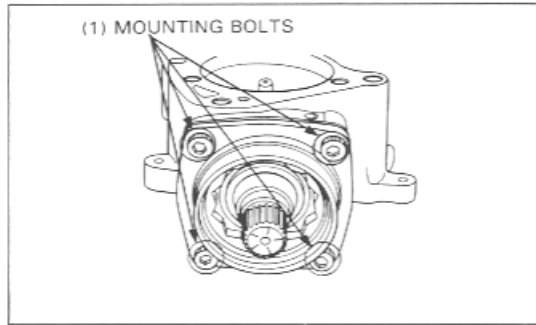

Place the output driven gear bearing holder in a vise with soft jaws. Unstake and remove the bearing outer race lock nut and discard it.

**S TOOL**

Lock nut wrench, 30 x 64 mm 07916-MB00001

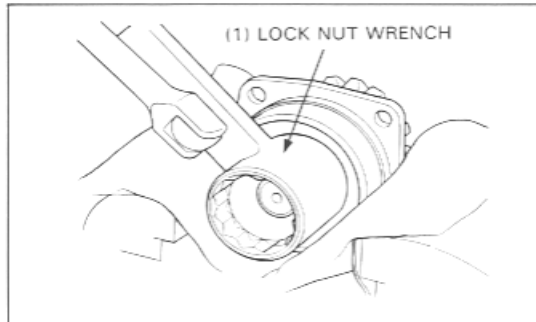

**Output Driven Gear Removal**

Press out the output driven gear out of the bearing holder using a hydraulic press.

**NOTE**

- Be careful not to damage the bearing holder gear case mating surface.

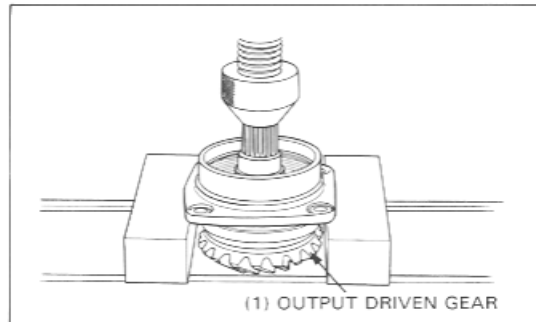

**Bearing Replacement**

Press the output driven gear bearing out of the bearing holder using a hydraulic press and common tool.

Press a new bearing into the bearing holder using a hydraulic press.

**S TOOL**

Driver 07749-0010000  
Attachment, 52 x 55 mm 07746-0010400  
Pilot, 30 mm 07746-0040700

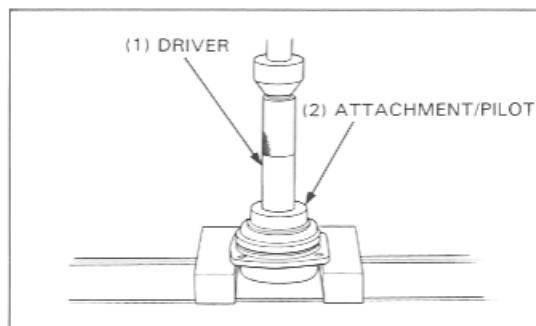

## Crankshaft/Transmission

### Output Driven Gear Installation

#### NOTE

- If the output driven gear requires replacement, the driven gear and drive shaft must be replaced as a set.

Support the bearing inner race and press the output driven gear in the bearing holder using a hydraulic press.

#### TOOL

Driver, 40 mm I.D. 07746-0030100  
Attachment, 30 mm I.D. 07746-0030300

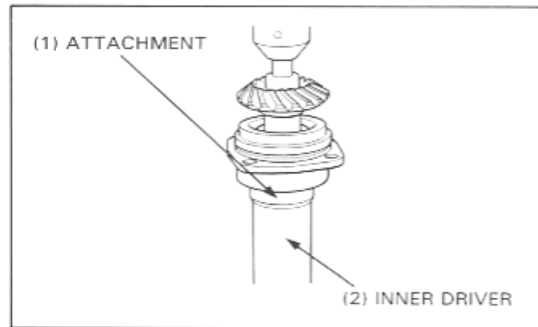

### Outer Race Lock Nut Installation

Place the bearing holder into a vise with soft jaws. Install and tighten a new bearing outer race lock nut.

Torque: 100 N·m (10.0 kg·m, 72 ft·lb)

Torque wrench scale reading: 91 N·m (9.1 kg·m, 65 ft·lb)

#### TOOL

Lock nut wrench, 30 x 64 mm 07916-MB00001

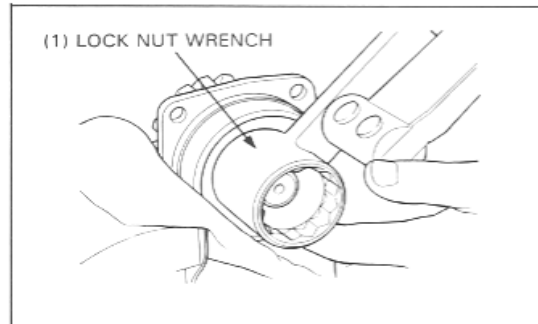

### Inner Race Lock Nut Installation

Install the driven gear bearing holder onto the gear case and install and tighten the bolts (page 10-18).

Hold the output driven gear with the shaft holder. Install and tighten a new bearing inner race lock nut.

Torque: 75 N·m (7.5 kg·m, 54 ft·lb)

Torque wrench scale reading: 69 N·m (6.9 kg·m, 50 ft·lb)

#### TOOL

Shaft holder 07923-6890101  
Lock nut wrench, 30 x 64 mm 07916-MB00001

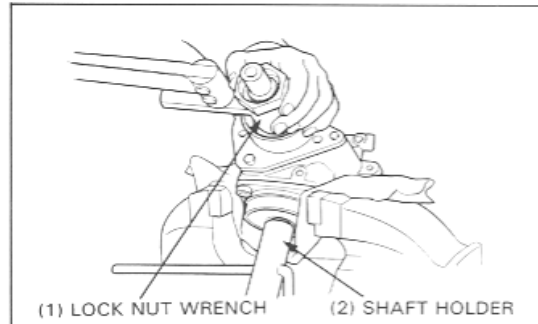

Stake the inner and outer race lock nuts.

Install a new oil seal on the bearing holder (page 10-18).

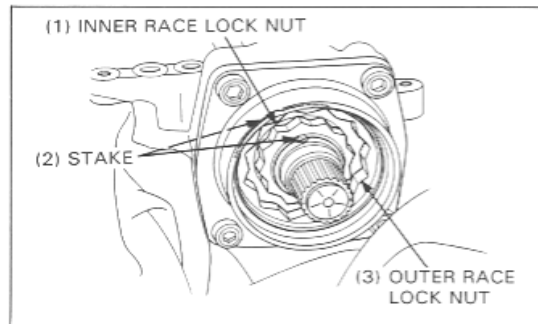

**Output Driven Gear Adjustment Shim**

Check the gear tooth contact pattern (see Section 15 of the Common Service Manual).  
If the pattern is not correct, remove and replace the driven gear adjustment shim.

Replace the shim with a thinner one if the contact pattern is too high.

Replace the driven gear adjustment shim with a thicker one if the contact pattern is too low.

The pattern will shift about 1.5–2.0 mm (0.06–0.08 in) when the thickness of the shim is changed by 0.10 mm (0.04 in).

**Output Driven Gear Adjustment Shim:**

- A: 0.40 mm (0.016 in)
- B: 0.45 mm (0.018 in)
- C: 0.50 mm (0.020 in) – Standard
- D: 0.55 mm (0.022 in)
- E: 0.60 mm (0.024 in)

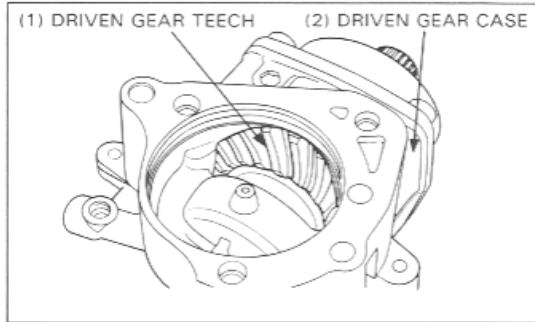

---

# 11. Final Drive

Service Information	11-1	Final Drive Disassembly	11-4
Troubleshooting	11-1	Final Drive Assembly	11-6
Final Drive Removal/Installation	11-2		

## Service Information

- The final drive gear assembly and drive shaft must be removed together.
- Replace all oil seals and O-rings whenever the final drive gear assembly is disassembled.
- Check the tooth contact pattern and gear backlash when the bearing, gear set and/or gear case have been replaced. (Section 15 of the Common Service Manual)

## Troubleshooting

### Excessive Noise

- Worn or scored ring gear shaft and driven flange
- Scored driven flange and wheel hub
- Worn or scored drive pinion and spline
- Worn pinion and ring gears
- Excessive backlash between pinion and ring gear
- Oil level too low

### Oil Leak

- Clogged breather
- Oil level too high
- Seals damaged



### Final Drive Removal/Installation

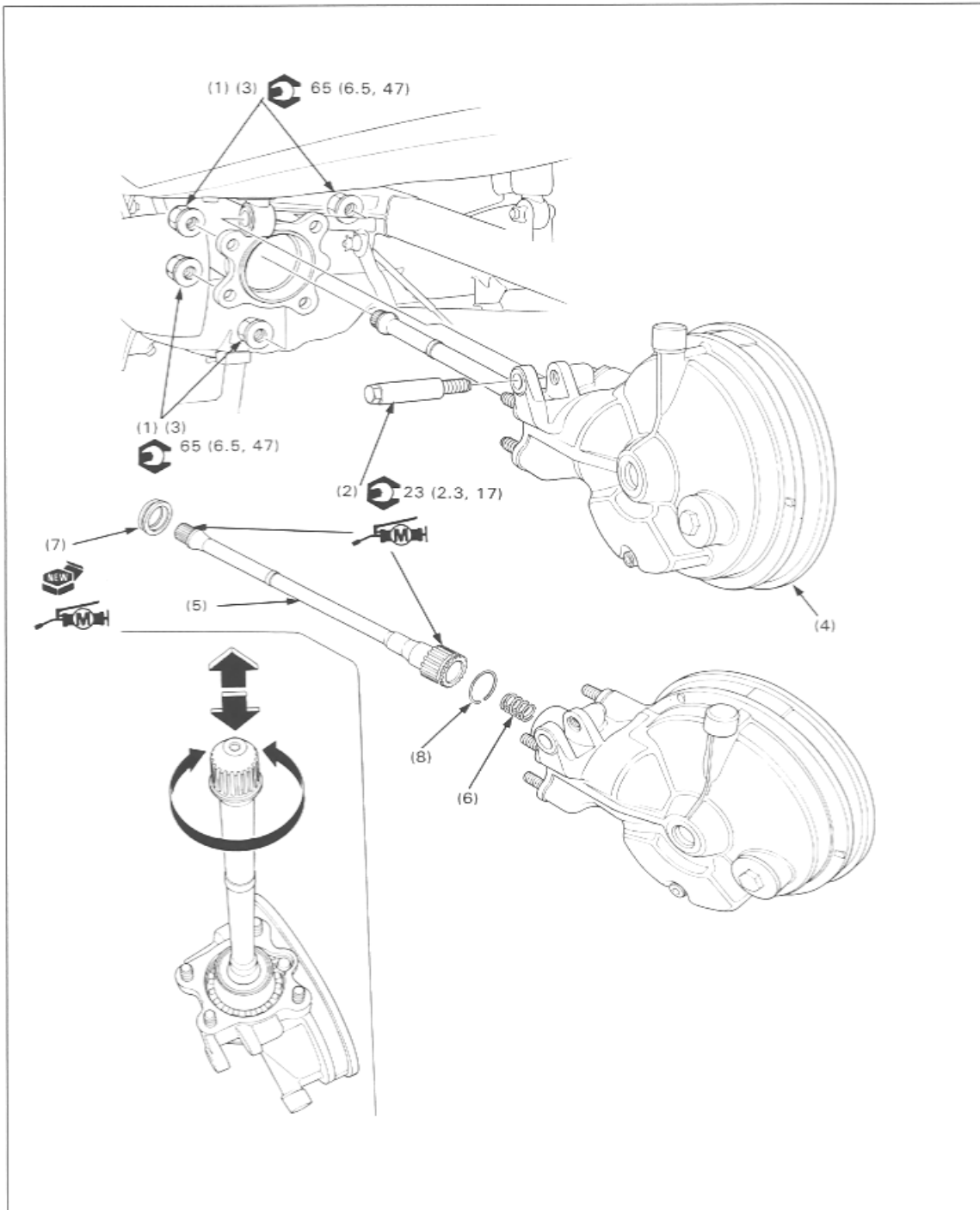

NOTE

- Final drive gear case assembly and drive shaft must be removed together.

Requisite Service

- Rear wheel removal/installation (page 13-2)
- Final gear oil draining

Procedure	Q'ty	Remarks
<b>Removal Order</b>		
(1) Final gear case mounting nut	4	Only loosen.
(2) Rear shock absorber lower mounting bolt	1	Support the final gear case assembly, then remove the nuts.
(3) Final gear case mounting nut	4	
(4) Final gear case assembly	1	NOTE • Gently pulling the drive shaft while moving it in a circular pattern.
(5) Drive shaft	1	
(6) Spring	1	
(7) Oil seal	1	
(8) Stop ring	1	
<b>Installation Order</b>		
(8) Stop ring	1	Replace the oil seal whenever it is removed.
(7) Oil seal	1	
(6) Damper spring	1	NOTE • Coat the pinion joint splines and drive shaft oil seal lip with Molybdenum disulfide grease. • Insert the drive shaft into the pinion joint until the stop ring seats in the pinion joint spline grooves. Make sure that the stop ring is seated properly by pulling on the drive shaft lightly. • Be careful not to damage the drive shaft oil seal.
(5) Drive shaft	1	
(4) Final gear case assembly	1	
(3) Final gear case mounting nut	3	Insert the drive shaft assembly into the swingarm and align the splines with the universal joint.
(2) Rear shock absorber lower mounting bolt	1	Support the final gear case assembly, then install the nuts.
(1) Final gear case mounting nut	3	Loosely install.

# Final Drive Disassembly

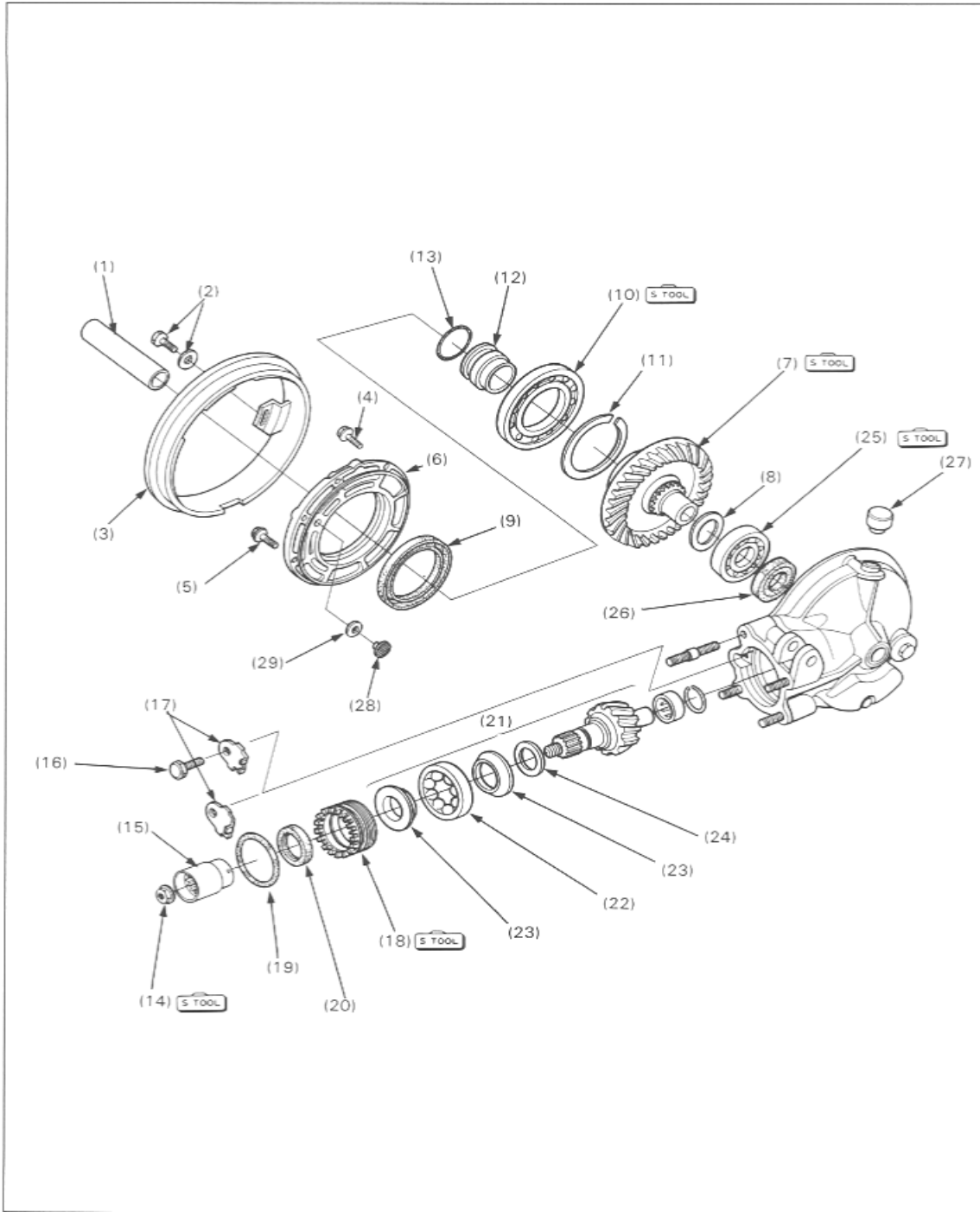

**▲ WARNING**

- Always wear gloves when handling a heated gear case to prevent burning your hands.

**CAUTION**

- Do not use a torch to heat the final gear case; it may cause warping.

**NOTE**

- Keep dust and dirt out of the gear case.
- Be careful not to damage the mating surfaces.

**Requisite Service**

- Final drive removal/installation (page 11-2)

Procedure	Q'ty	Remarks
<b>Disassembly Order</b>		
(1) Distance collar	1	
(2) Bolt/washer	1/1	
(3) Dust guard plate	1	Remove the dust guard plate by turning it clockwise.
(4) Gear case cover bolt 8 mm	6	Loosen the bolts in crisscross pattern in 2 or 3 steps.
(5) Gear case cover bolt 10 mm	2	
(6) Gear case cover	1	
(7) Ring gear	1	<b>NOTE</b> • If the ring gear stays in the cover, press the ring gear out of the cover.
(8) Wave washer	1	
(9) Oil seal	1	
(10) Ring gear bearing	1	(See page 11-8).
(11) Spacer	1	
(12) O-ring guide	1	
(13) O-ring	1	Remove the O-ring guide by tapping it from the opposite side. (See page 11-8).
(14) Pinion shaft nut	1	
(15) Pinion joint	1	
(16) Bearing retainer lock tab bolt	1	
(17) Bearing retainer lock tab	1	
(18) Pinion retainer	1	(See page 11-8).
(19) O-ring	1	Remove from the pinion retainer.
(20) Oil seal	1	
(21) Pinion assembly	1	(See page 11-9).
(22) Pinion bearing	1	Pull the bearing outer and inner races off the shaft with the bearing puller.
(23) Bearing inner race	2	
(24) Spacer	1	
(25) Final gear case cover bearing	1	(See page 11-9).
(26) Oil seal	1	
(27) Breather cap	1	
(28) Ring gear stop pin	1	
(29) Stop pin shim	1	

# Final Drive Assembly

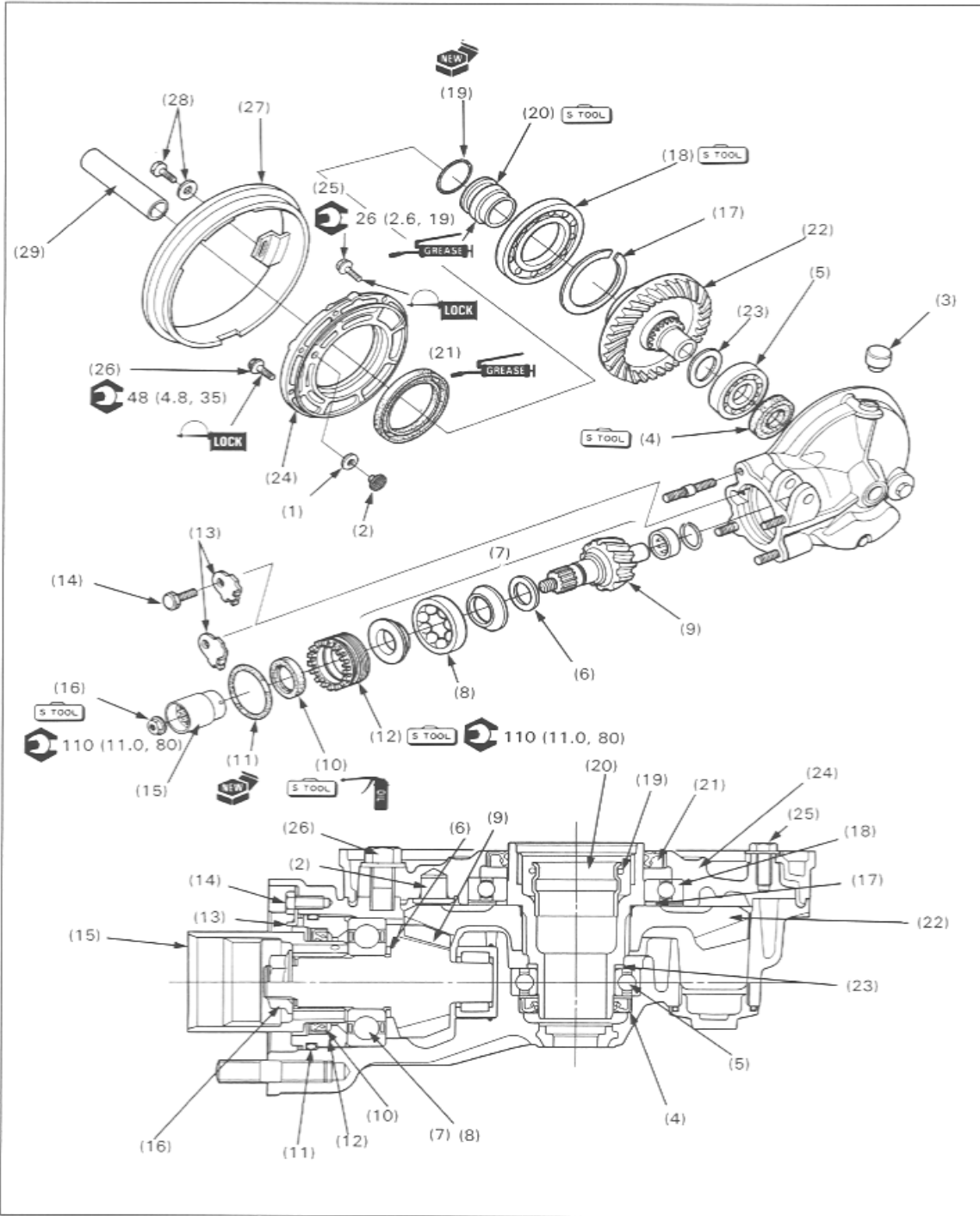

## NOTE

- Keep dust and dirt out of the gear case.
- Be careful not to damage the mating surface.
- If the gear set, pinion bearing, ring gear bearing and/or gear case are replaced, install a 2.0 mm (0.08 in) thick spacer.
- Replace the ring gear and pinion gear as a set.

## Requisite Service

- Final drive removal/installation (page 11-2)

Procedure	Q'ty	Remarks
<b>Assembly Order</b>		
(1) Stop pin shim	1	(See page 11-11).
(2) Ring gear stop pin	1	
(3) Breather cap	1	Clean the breather hole, then install it.
(4) Oil seal	1	
(5) Final gear case cover bearing	1	
(6) Spacer	1	NOTE
(7) Pinion assembly	1	• When the gear set, pinion bearing and/or gear case are replaced, use a 2.0 mm (0.08 in) thick spacer. (See page 11-10).
(8) Bearing inner race	2	
(9) Pinion bearing	1	
(10) Oil seal	1	Install the new oil seal and O-ring into the pinion retainer.
(11) O-ring	1	
(12) Pinion retainer	1	Coat the O-ring and threads on the pinion retainer with gear oil. Screw the pinion retainer in, pressing the pinion bearing in place, then tighten.
(13) Bearing retainer lock tab	1	NOTE
(14) Bearing retainer lock tab bolt	1	• There are two type (A or B) of lock tabs available.
(15) Pinion joint	1	Coat the oil seal lip contact surface of the pinion joint with oil and install the pinion joint.
(16) Pinion shaft nut	1	(See page 11-12).
(17) Spacer	1	NOTE
(18) Ring gear bearing	1	• When the gear set, pinion bearing and/or gear case are replaced, use a 2.0 mm (0.08 in) thick spacer. (See page 11-10).
(19) O-ring	1	Install it O-ring guide.
(20) O-ring guide	1	
(21) Oil seal	1	
(22) Ring gear	1	• Install into the gear case cover, check the stop pin shim clearance (page 11-12).
(23) Wave washer	1	Install it into the gear case.
(24) Gear case cover	1	• Clean all sealing material off the mating surface of the gear case and cover.
(25) Gear case cover bolt 8 mm	6	• Apply liquid sealant to the mating surface.
(26) Gear case cover bolt 10 mm	2	• Tighten the bolts in a crisscross pattern in 2 or 3 steps.
(27) Dust guard plate	1	• Apply a locking agent to the threads.
(28) Bolt/washer	1/1	
(29) Distance collar	1	

## Final Drive

### Ring Gear Removal

Remove the bolt and case cover (page 11-4).

If the ring gear stays in the cover, do the following:  
Place the cover in a press with the ring gear down.  
Make sure the cover is securely supported.  
Press the ring gear out of the cover.

 S TOOL

**Driver** 07749-0010000  
**Attachment, 52 x 55 mm** 07746-0010400

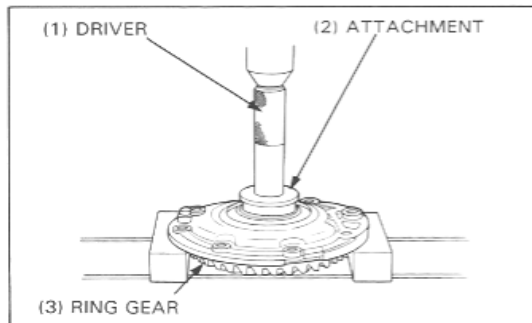

### Ring Gear Bearing Removal

Remove the ring gear bearing with special tool. Remove the gear adjusting spacer.

 S TOOL

**Bearing puller & driver attachment** 07934-MB00000 or commercially available two-jaw puller

#### NOTE

- Never reinstall old bearings; once bearings are removed, they must be replaced with new ones.

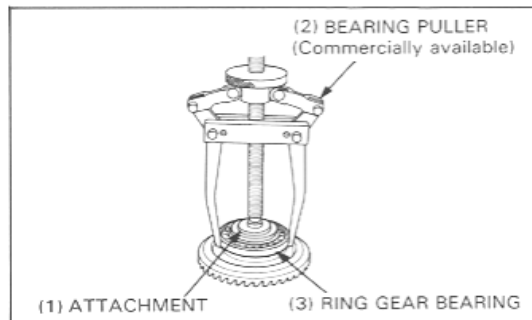

### Pinion Gear Removal

Install the pinion joint holder and remove the pinion shaft nut.

 S TOOL

**Pinion joint holder** 07926-ME90000

Remove the tool and pinion joint.  
Remove the retainer lock tab.

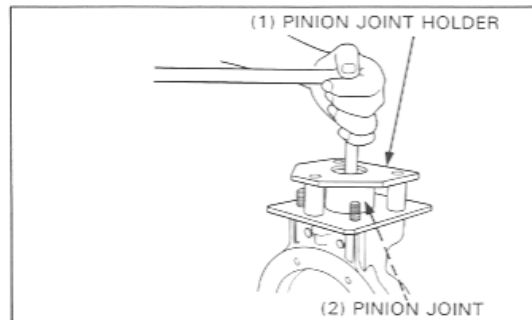

Remove the pinion retainer with the pinion retainer wrench.

 S TOOL

**Pinion retainer wrench** 07910-MA10100 or 07910-ME80000 (U.S.A. only)

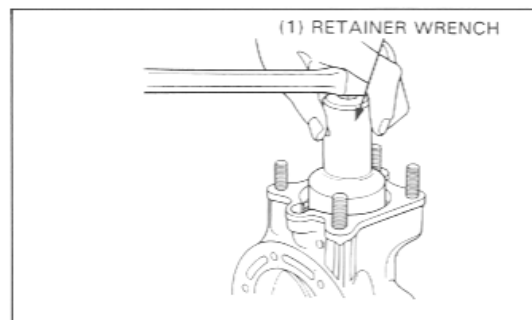

Pull the pinion gear assembly off with the pinion puller.

**5 TOOL**

Pinion puller set 07935—MM80100 or  
 U.S.A. only:  
 Puller shaft, 22 x 1.5 x 240 mm 07931—ME4010B  
 Special nut 07931—HB3020A  
 Puller base, A 07HMC—MM8011A

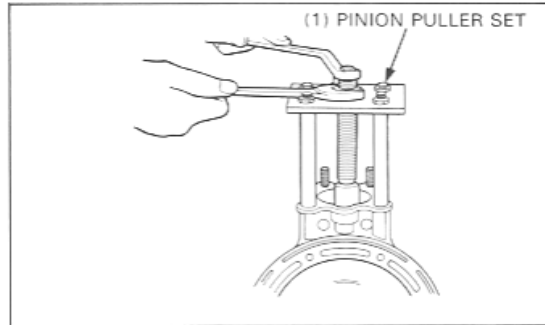

### Case Bearing Removal

Heat the gear case to approximately 80°C (176°F).  
 Tap the gear case with a plastic hammer and remove the ring gear bearing.

**▲ WARNING**

- Always wear gloves when handling the gear case after it has been heated.

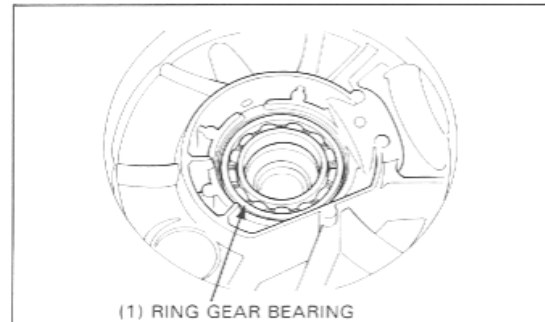

### Pinion Retainer Oil Seal Replacement

Remove the O-ring and oil seal from the pinion retainer (page 11-4).  
 Drive a new oil seal into the retainer.

**5 TOOL**

Driver 07749—0010000  
 Ball race and bearing driver attachment 07945—3330300

Coat the new O-ring with oil and install it on the retainer.

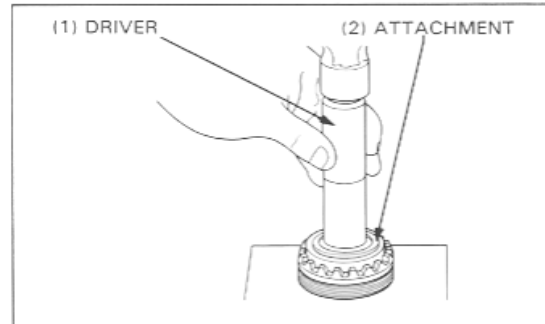

### Case Oil Seal Replacement

Remove the case bearing and oil seal (page 11-4).  
 Drive a new oil seal into the case.

**5 TOOL**

Driver 07749—0010000  
 Attachment 07945—3330300

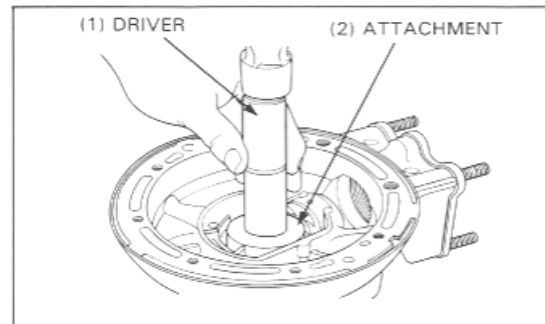

## Final Drive

### Pinion Gear Assembly

Install the original pinion gear spacer, press the pinion bearing onto the shaft until it seats (page 11-6).

Place the pinion assembly into the gear case and drive it until enough threads are visible to engage the pinion retainer.

#### 5 TOOL

**Bearing race insert attachment** 07931-4630300 or  
U.S.A. only:  
**Fork seal driver** 07947-3710101  
**Attachment, 37 x 40 mm** 07746-0010200  
**Driver** 07749-0010000

Coat the O-ring and threads on the pinion retainer with gear oil.

Screw the pinion retainer in, pressing the pinion bearing in place, then tighten to the specified torque.

**Torque: 110 N·m (11.0 kg·m, 80 ft·lb)**

#### 5 TOOL

**Pinion retainer wrench** 07910-MA10100 or  
07910-ME80000  
(U.S.A. only)

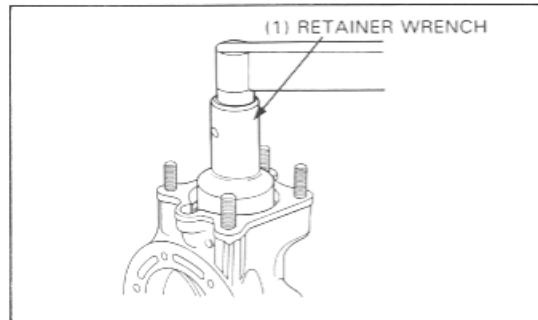
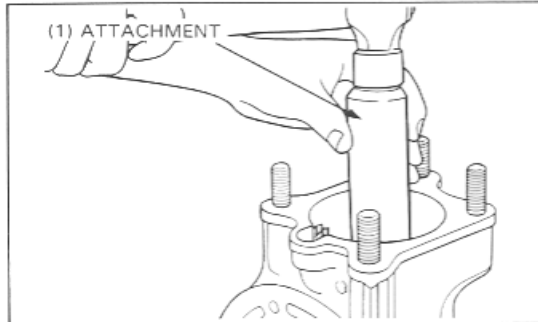

### Ring Gear Assembly

#### Ring Gear Bearing Installation

If the ring gear assembly was loose against the cover, do the following:

Install the original spacer onto the ring gear.

#### NOTE

- If the gear set, pinion bearing, ring gear bearing and/or gear case is replaced, install a 2.00 mm (0.079 in) thick spacer (standard).

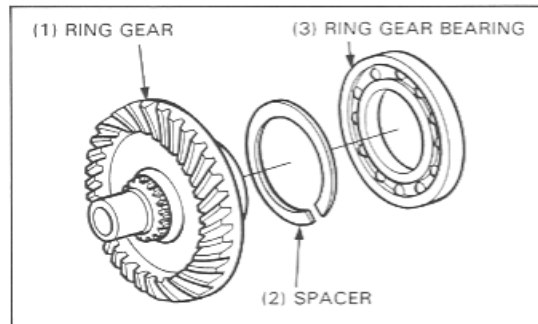

Place a new ring gear bearing over the ring gear shaft.

Then press the new bearing onto the shaft with the special tool.

#### 5 TOOL

**Bearing puller & driver attachment** 07934-MB00000 or  
07965-MB00100

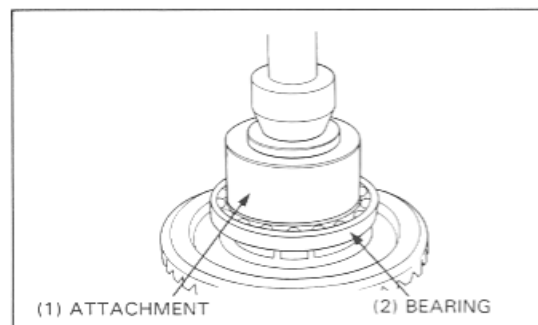

If the ring gear remained in the cover, do the following:  
Press the ring gear bearing into the cover.

**S TOOL**

**Driver** 07749—0010000  
**Bearing driver attachment** 07GAD—SD40101

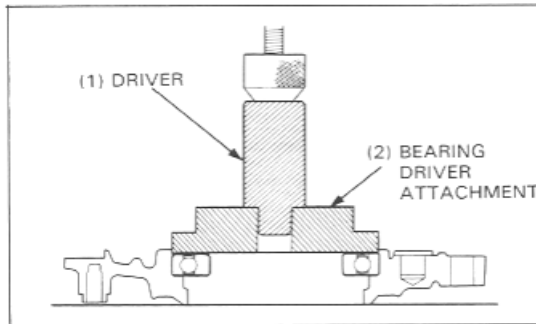

Install the original spacer on the ring gear.

**NOTE**

- If the gear set, pinion bearing, ring gear bearing and/or gear case is replaced, install a 2.00 mm (0.079 in) thick spacer (standard).

Support the bearing inner race with the bearing puller & attachment, and press the ring gear into the bearing using the special tool.

**S TOOL**

**Bearing puller & driver attachment** 07934—MB00000 or  
07965—MB00100

**O-ring Guide Installation**

Install the new O-ring on the O-ring guide (page 11-6).

Apply grease to the O-ring and drive the O-ring guide into the ring gear shaft.

**S TOOL**

**Driver** 07749—0010000  
**Attachment, 42 x 47 mm** 07746—0010300

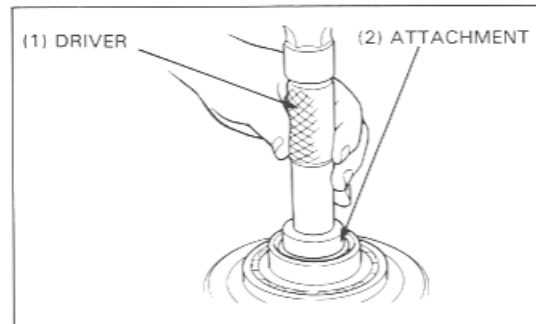
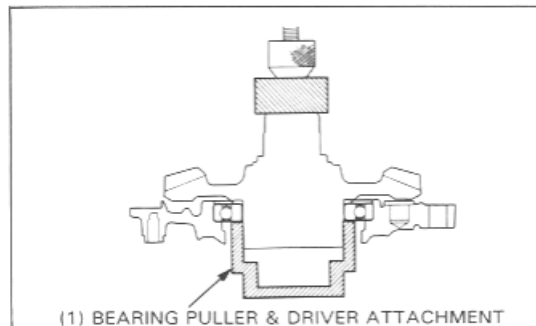

**Stop Pin Adjustment Shim Replacement**

Check the clearance between the ring gear and the ring gear stop pin.

If the clearance exceeds the service limit, remove the ring gear.

**Service Limit:** 0.30—0.60 mm (0.012—0.024 in)

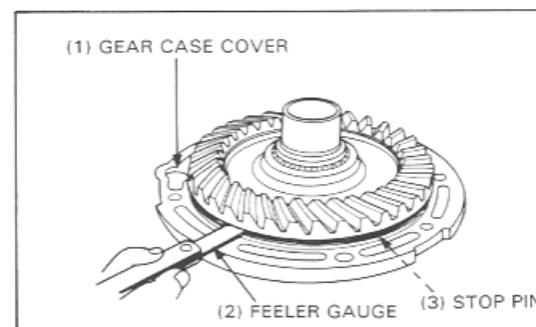

## Final Drive

If the clearance exceeds the service limit, heat the gear case cover to approximately 80°C (176°F) and remove the stop pin by tapping the cover.

### ⚠ WARNING

- Always wear gloves when handling the gear case after it has been heated.

Install a stop pin shim to obtain the correct clearance.

**Shim Thickness:** A: 0.10 mm (0.004 in)  
B: 0.15 mm (0.006 in)

Install the shim and drive the stop pin into the case cover.

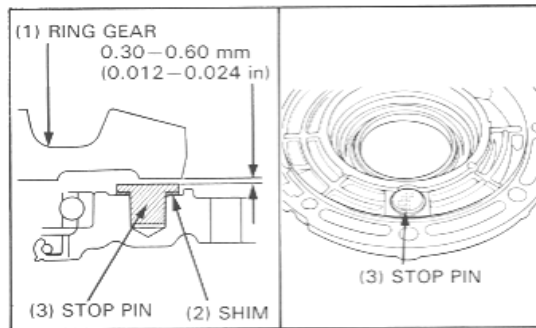

### Pinion Spacer Replacement

Check the gear tooth contact pattern (See Common Service Manual).

If the patterns are not correct, remove and change the pinion spacer.

Replace the pinion spacer with a thicker one if the contact pattern is too high.  
Replace the pinion spacer with a thinner one if the contact pattern is too low.

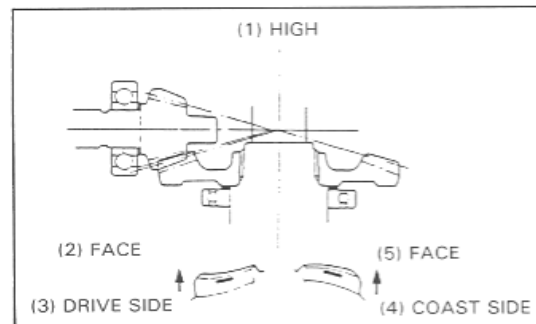

The pattern will shift about 1.5–2.0 mm (0.06–0.08 in) when the thickness of the spacer is changed by 0.1 mm (0.004 in).

### Pinion Spacer:

- A: 1.82 mm (0.072 in)
- B: 1.88 mm (0.074 in)
- C: 1.94 mm (0.076 in)
- D: 2.00 mm (0.079 in)—Standard
- E: 2.06 mm (0.081 in)
- F: 2.12 mm (0.083 in)
- G: 2.18 mm (0.086 in)

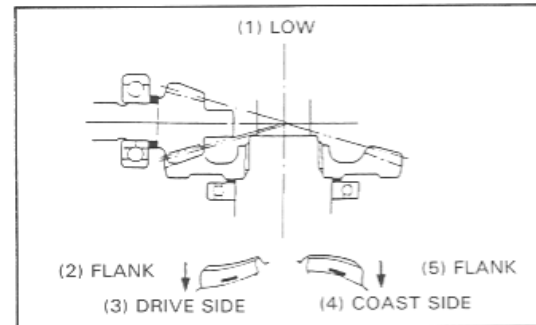

### Ring Gear Spacer Replacement

Set the dial indicator, check the backlash (see specification page 1-10).

Remove the dial indicator, turn the ring gear 120° and measure backlash. Repeat this procedure once more.

Compare the difference between the three measurements.

**Difference of measurements:**  
**Service Limit:** 0.10 mm (0.004 in)

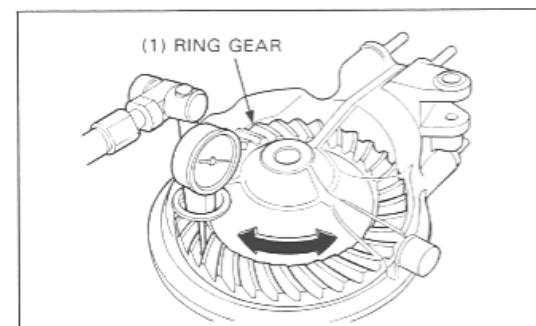

If the backlash is excessive, replace the ring gear spacer with a thicker one.

If the backlash is too small, replace the ring gear spacer with a thinner one.

Backlash is changed by about 0.06–0.07 mm (0.002–0.003 in) when the thickness of the spacer is changed by 0.10 mm (0.004 in).

#### Ring Gear Spacer:

- A: 1.82 mm (0.072 in)
- B: 1.88 mm (0.074 in)
- C: 1.94 mm (0.076 in)
- D: 2.00 mm (0.079 in) – Standard
- E: 2.06 mm (0.081 in)
- F: 2.12 mm (0.083 in)
- G: 2.18 mm (0.086 in)
- H: 2.24 mm (0.088 in)
- I: 2.30 mm (0.091 in)

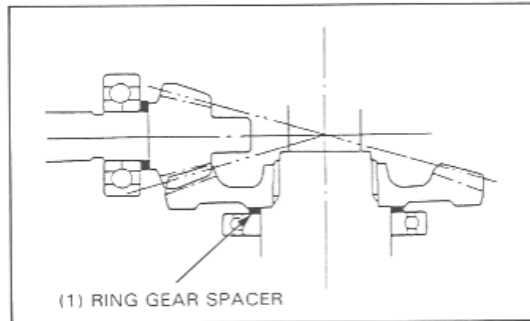

#### Pinion Joint Installation

Install the appropriate pinion lock tab (page 11-6).

Coat the oil seal lip contact surface of the pinion joint with oil and install the pinion joint.

Install the pinion joint holder and tighten the pinion nut.

**Torque: 110 N·m (11.0 kg-m, 80 ft-lb)**

#### TOOL

Pinion joint holder	07926–ME90000
Joint holder attachment	07HMB–MM80100

Remove the pinion joint holder.

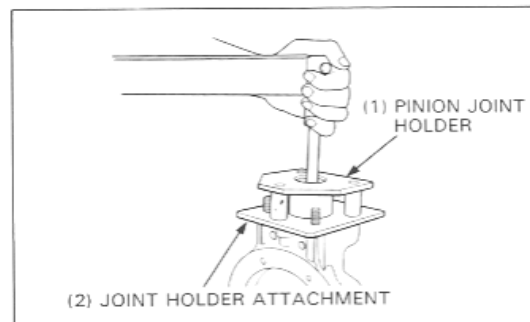

---

## 12. Front Wheel/Suspension/Steering

Service Information	12-1	Fork Disassembly	12-12
Troubleshooting	12-1	Fork Assembly	12-14
Handlebar Disassembly/Assembly	12-2	Anti-dive Case Disassembly/Assembly	12-16
Handlebar Removal/Installation	12-4	Turn Signal Cancel Control Unit (Angle Sensor) Removal/Installation ('89 – '90, '94 – '96)	12-18
Front Wheel Removal/Installation	12-6	Steering Stem Removal	12-20
Front Wheel Disassembly/Assembly	12-8	Steering Stem Installation	12-22
Fork Removal/Installation	12-10		

### Service Information

- When servicing the front wheel, support the motorcycle securely with a jack or other support under the engine.
- Refer to the section 14 for brake system information.
- Use only tires marked "TUBELESS" and tubeless valves on rims marked "TUBELESS TIRE APPLICABLE".

### Troubleshooting

#### Hard Steering

- Faulty steering head bearings
- Damaged steering head bearings
- Insufficient tire pressure
- Faulty tire
- Steering head bearing adjustment nut too tight

#### Steers to One Side or Does Not Track Straight

- Unevenly adjusted right and left shock absorbers
- Bent fork
- Bent front axle: wheel installed incorrectly
- Faulty steering head bearings
- Bent frame
- Worn wheel bearings
- Worn swingarm components

#### Front Wheel Wobbling

- Bent rim
- Worn front wheel bearings
- Faulty tire

#### Wheel Turns Hard

- Faulty wheel bearings
- Faulty speedometer gear

#### Soft Suspension

- Insufficient or wrong type of fluid in fork
- Low fluid level in fork
- Faulty anti-dive system

#### Hard Suspension

- Incorrect fluid weight
- Bent fork tubes
- Clogged fluid passage

#### Front Suspension Noisy

- Insufficient fluid in fork
- Loose fork fasteners
- Lack of grease in speedometer gearbox

12

# Handlebar Disassembly/Assembly

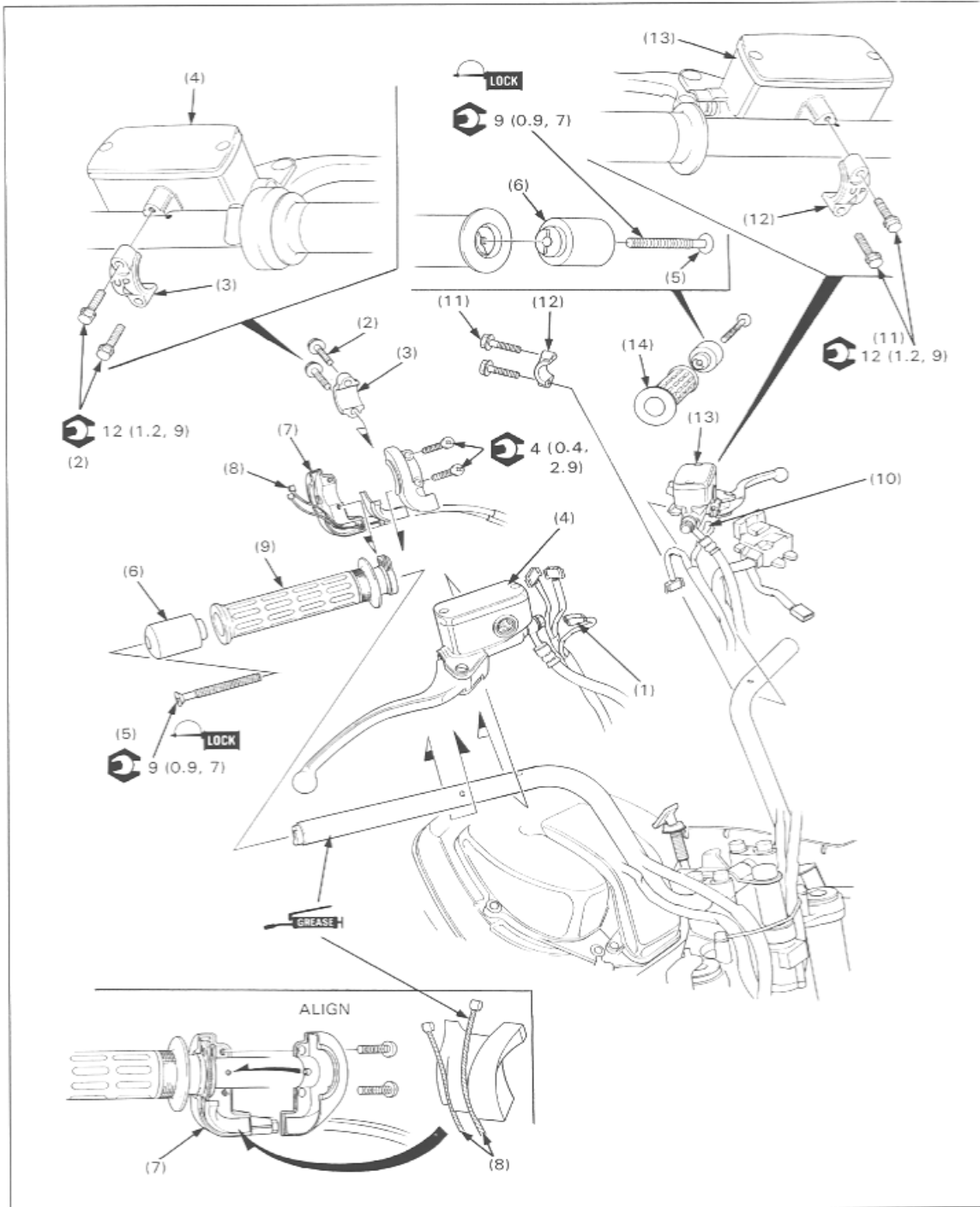

**▲WARNING**

- Contaminants in the system may cause a reduction or loss of braking ability.

**CAUTION**

- Spilled brake fluid will damage painted, plastic, or rubber parts.

**Requisite Service**

- Handlebar cover removal (Section 2).

Procedure	Q'ty	Remarks
<b>Disassembly Order</b>		Assembly is in the reverse order of the disassembly.
(1) Brake switch wire	1	Disconnect from the switch terminal.
(2) Master cylinder holder bolt	2	At installation: Tighten the upper bolt first, then tighten the lower bolt.
(3) Master cylinder holder	1	At installation: Install the holder with it's "UP" mark facing up.
(4) Brake master cylinder	1	<b>CAUTION:</b> • Keep master cylinder upright. • Do not disconnect the hydraulic line.
(5) Grip end weight mounting screw	2	Threads locking agent applied.
(6) Grip end weight	2	
(7) Throttle housing	1	At installation: Tighten the upper screw first, then the lower.
(8) Throttle cable	2	Disconnect the cable from the grip.
(9) Throttle grip	1	
(10) Clutch switch wire	1	Disconnect from the switch terminal.
(11) Clutch master cylinder holder bolt	2	At installation: Tighten the upper bolt first, then tighten the lower bolt.
(12) Clutch master cylinder holder	1	At installation: Install the holder with it's "UP" mark facing up.
(13) Clutch master cylinder	1	<b>CAUTION:</b> • Keep master cylinder upright. • Do not disconnect the hydraulic line.
(14) Left handle grip	1	At installation: • Install the grip onto the pipe with the adhesive. • Allow the adhesive to dry an hour before using.

## Handlebar Removal/Installation

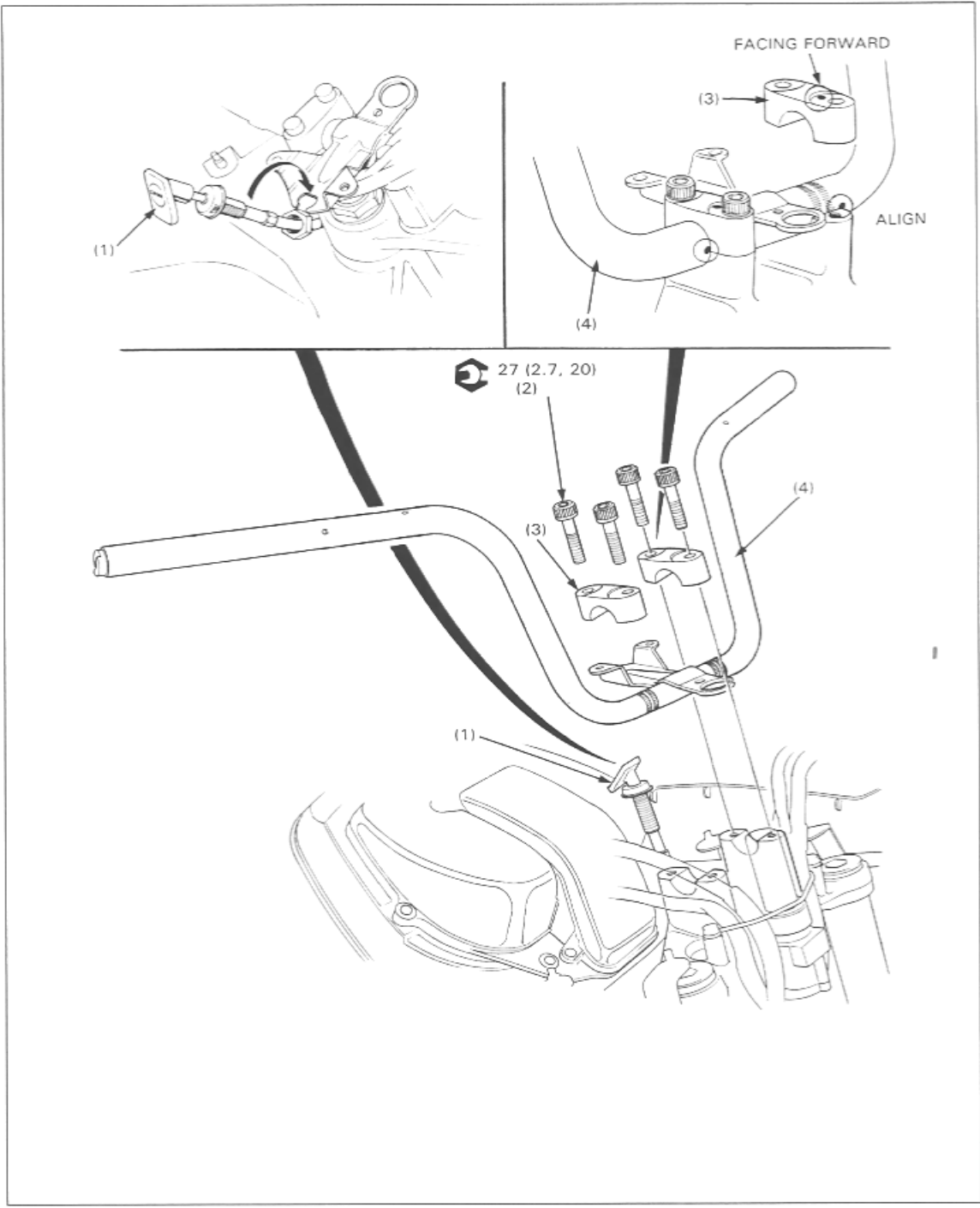

**Requisite Service**

- Handlebar disassembly/assembly (page 12-2).

Procedure		Q'ty	Remarks
<b>Removal Order</b>			
(1)	Choke control knob	1	Loosen the lock nut and pull the knob up off the holder. Remove the holder bolts while holding the handlebar to prevent damage the serration on the handlebar holders.
(2)	Handlebar holder bolt	4	
(3)	Handlebar upper holder	2	
(4)	Handlebar	1	
<b>Installation Order</b>			
(4)	Handlebar	1	Place the handlebar onto the lower holder and align the punch marks on the handlebar with upper surfaces. Install the upper holder with its punch mark facing forward.
(3)	Handlebar upper holder	2	
(2)	Handlebar holder bolt	4	Tighten the front bolts first, then tighten the rear bolts. Install the choke knob onto the holder and align the cutout with the choke knob holder.
(1)	Choke control knob	1	

# Front Wheel Removal/Installation

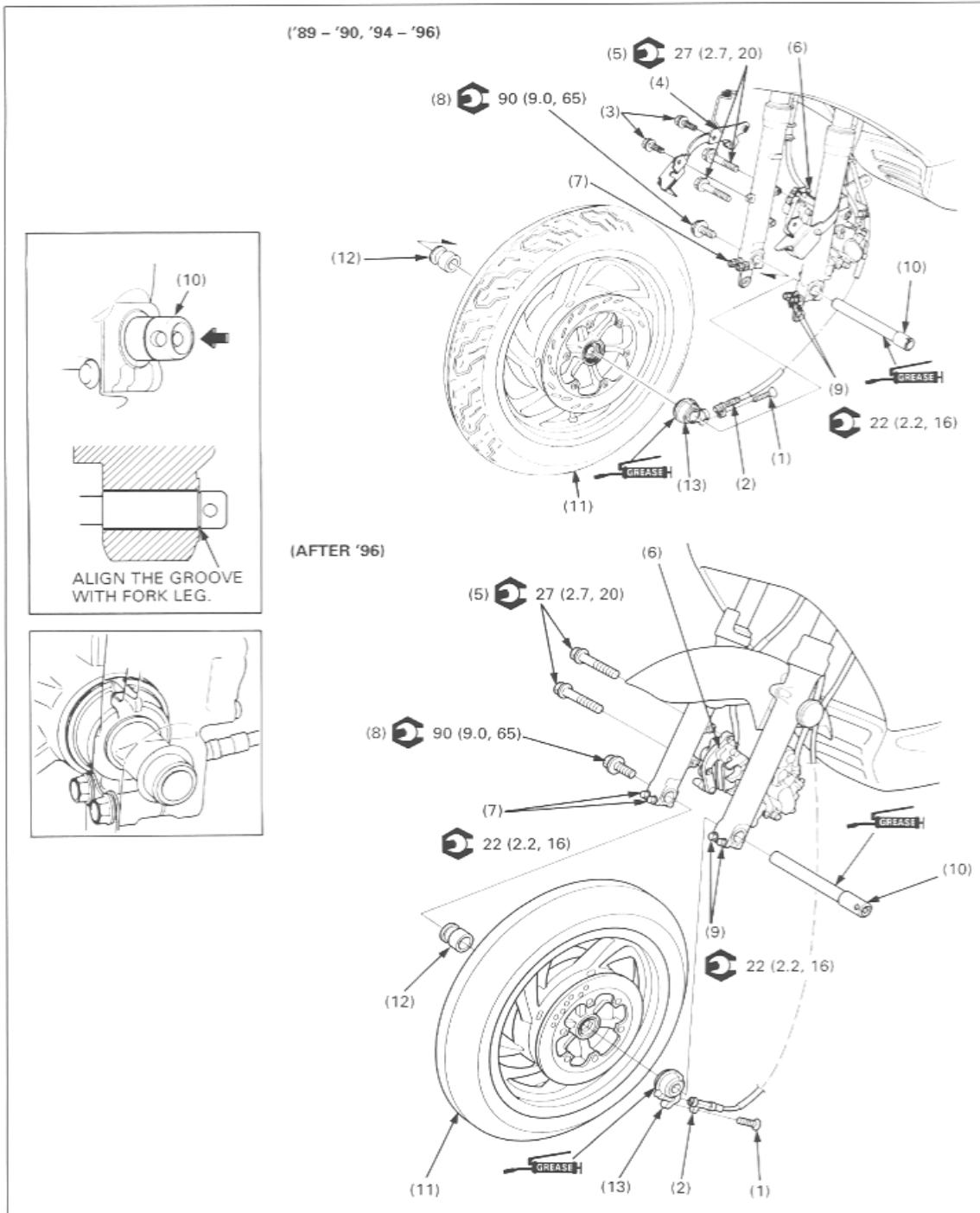

**⚠ WARNING**

- A contaminated brake disc or pad reduces stopping ability.

**CAUTION**

- When the front wheel service, place a floor jack or other adjustable support under the engine. Carefully align the jack to prevent damage the exhaust pipe.

**NOTE**

- Do not apply the brake lever after the front wheel is removed.
- Do not add more than 60 grams to the wheel balance weight.
- Apply a thin coat clean grease to the front axle before installation.
- Check the clearance between the brake disc and caliper bracket on each side after installation. The clearance should be at least 0.7 mm (0.03 in).

**Requisite Service**

- Raise the front wheel off the ground and support the motorcycle.

Procedure	Q'ty	Remarks
<b>Removal Order</b>		
(1) Speedometer cable setting screw	1	
(2) Speedometer cable	1	Disconnect from the gear box.
(3) Front fender bracket bolt	2	('89 - '90, '94 - '96 only)
(4) Front fender bracket	1	
(5) Right brake caliper mounting bolt	2	
(6) Right brake caliper	1	<b>CAUTION:</b> • Do not support the caliper by the brake hose.
(7) Axle shaft pinch bolt	2	Loosen.
(8) Axle bolt	1	Loosen and remove it.
(9) Axle shaft pinch bolt	2	Loosen.
(10) Axle	1	
(11) Front wheel assembly	1	Disassembly (page 12-8).
(12) Axle side collar	1	
(13) Speedometer gear box assembly	1	
<b>Installation Order</b>		
(13) Speedometer gear box assembly	1	Align the tangs with the slots on the wheel.
(12) Axle side collar	1	Apply grease to the dust seal.
(11) Front wheel assembly	1	<b>CAUTION:</b> • Fit the left brake disc carefully between the brake pads to avoid damaging the pads.
(10) Axle	1	• Apply thin coating of grease. • Align the gear box with fork leg stopper. • Insert the axle onto the fork leg. Align the outer surface of the fork leg with the groove of the axle.
(8) Axle bolt	1	Screw in the bolt.
(9) Axle shaft pinch bolt	2	Tighten the axle bolt first, then torque the pinch bolt.
(6) Right brake caliper	1	
(5) Right brake caliper mounting bolt	2	<b>NOTE:</b> • Make sure that the brake caliper clearance is correct.
(7) Axle shaft pinch bolt	2	<b>NOTE:</b> • With the front brake applied, pump the fork up and down several times to seat the axle and check front brake operation.
(4) Front fender bracket	1	('89 - '90, '94 - '96 only)
(3) Front fender bracket bolt	2	
(2) Speedometer cable	1	Connect to the gear box.
(1) Speedometer cable setting screw	1	

# Front Wheel Disassembly/Assembly

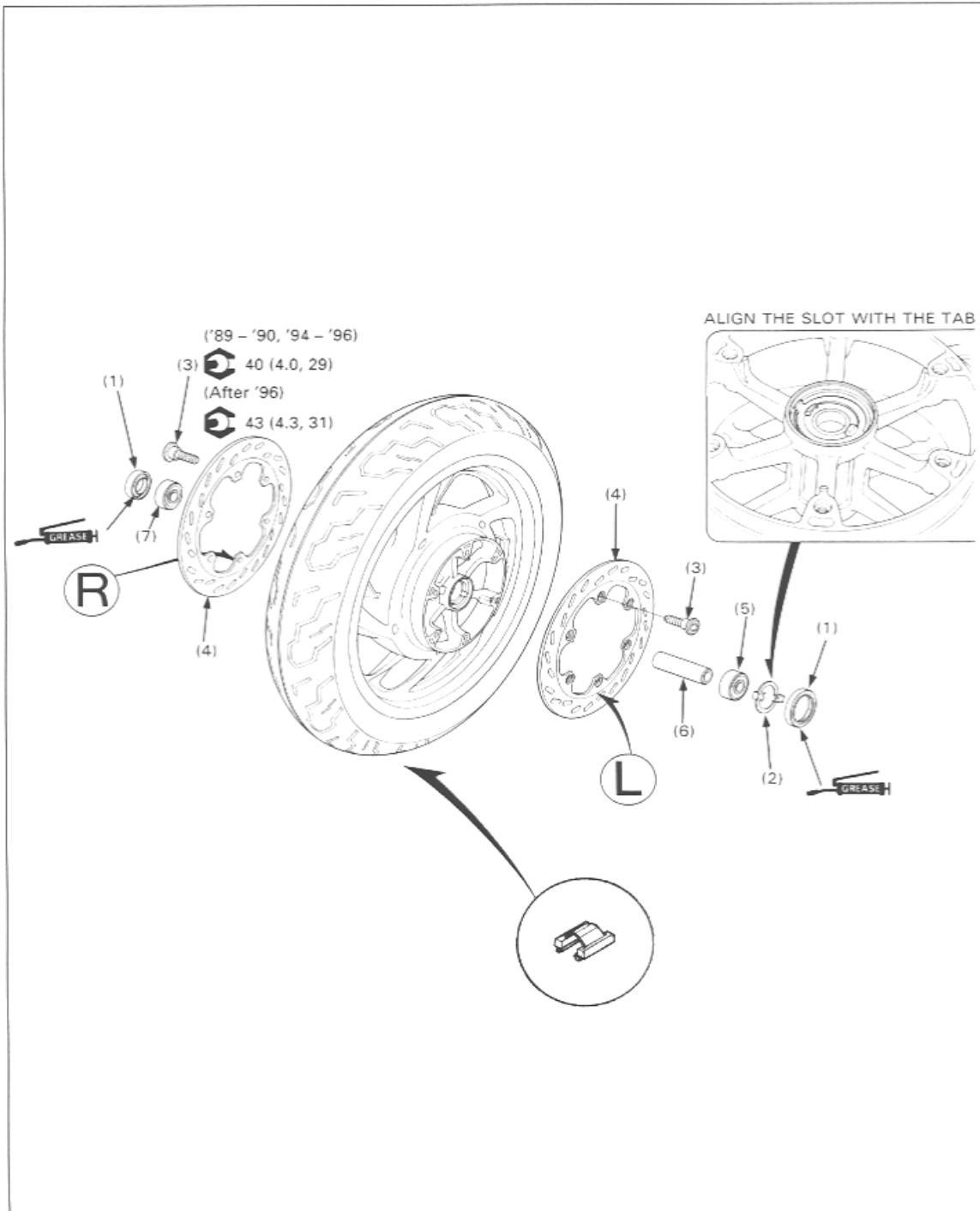

**▲ WARNING**

- Do not get grease on the brake disc, or stopping power will be reduced.

NOTE

- Replace the wheel bearings in pairs.
- Do not add more than 60 grams to the wheel balance weight.
- Refer to the Common Service Manual, section 1 for wheel bearing replacement.

**Requisite Service**

- Front wheel removal (page 12-6)

Procedure		Q'ty	Remarks
	<b>Disassembly Order</b>		Assembly is in the reverse order of the disassembly.
(1)	Dust seal	2	
(2)	Speedometer gear retainer	1	
(3)	Brake disc retaining bolt	12	Thread locking agent applied.
(4)	Brake disc	2	At installation: Install the brake discs onto the wheel hub with marks ("L" or "R") facing out.
(5)	Left wheel bearing (6004 UU)	1	
(6)	Distance collar	1	At installation: Be certain the distance collar is in position before installing the left bearing.
(7)	Right wheel bearing (6004 UU)	1	At installation: Drive a new right bearing into the hub first, then drive a new left bearing in.



**NOTE**

- If the fork legs will be disassembled:
  - loosen the top bridge pinch bolts first, then the fork cap bolts but do not remove them yet.
  - break the socket bolts in the bottom of the fork sliders loose, but do not unscrew them.

**Requisite Service**

- Front wheel removal (page 12-6)
- Front fender removal (Section 2)
- Center cover removal (Section 2)

Procedure	Q'ty	Remarks
<b>Removal Order</b>		
(1) Fender frame bolt	4	('89 - '90, '94 - '96 only)  • By removing the mounting bolts. • Do not hang the caliper by the brake hose.  Loosen the bolt. Be sure to hold the fork leg while loosening the bolts. Disassembly: (page 12-12)
(2) Fender frame	1	
(3) Brake caliper	1	
(4) Top bridge pinch bolt	1	
(5) Bottom bridge pinch bolt	2	
(6) Fork leg	1	
<b>Installation Order</b>		
(6) Fork leg	1	Be sure to hold the fork leg while torquing the bolts. After assembling the fork leg: torque the tube caps first, then torque the top bridge pinch bolt.  By attaching the mounting bolts. ('89 - '90, '94 - '96 only)
(5) Bottom bridge pinch bolt	2	
(4) Top bridge pinch bolt	1	
(3) Brake caliper	1	
(2) Fender frame	1	
(1) Fender frame bolt	4	

# Fork Disassembly

'89 - '90, '94 - '96 shown:

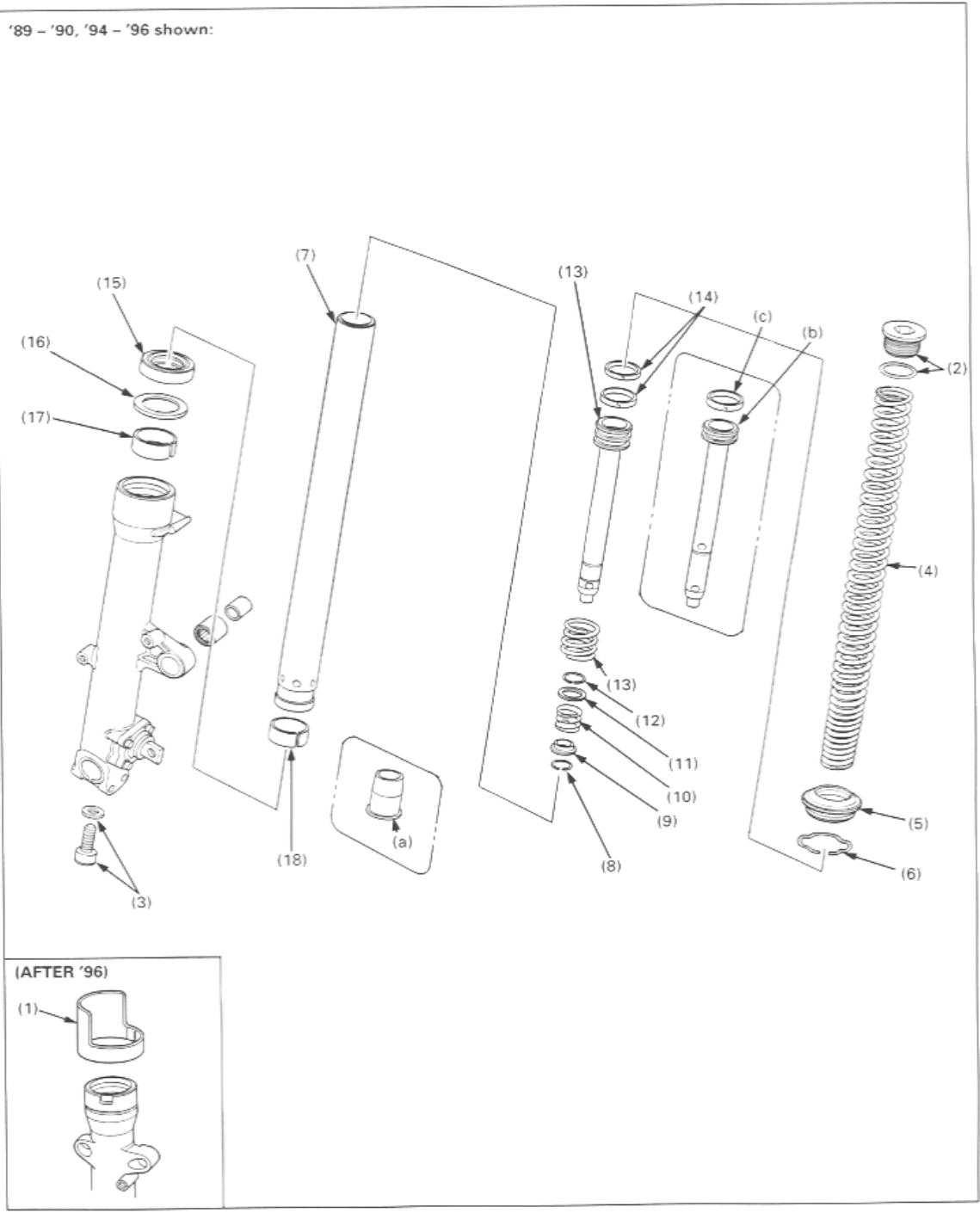

**▲ WARNING**

- The fork cap bolt is under spring pressure. Use care when removing it and wear eye and face protection.

NOTE

- Temporarily install the fork spring and fork cap bolt to loosen the socket bolt.
- Left slider case needle bearing replacement (page 12-17).
- Refer to the Common Service Manual, section 18, for fork Dis/Assembly.

**Requisite Service**

- Fork removal (page 12-10)

Procedure	Q'ty	Remarks
<b>Disassembly Order</b>		
(1) Fork protector	1	(After '96)
(2) Fork cap bolt/O-ring	1	
(3) Socket bolt/washer	1	
(4) Fork spring	1	Pour out the fork oil after removing the fork spring.
(5) Dust seal	1	<b>CAUTION:</b>
(6) Stop ring	1	• Do not scratch the fork tube sliding surface.
(7) Fork tube	1	
<b>Right Fork Leg Only:</b>		
(a) Oil lock piece	1	Remove them from the inner fork tube.
(b) Fork piston	1	Do not remove it, unless it is necessary to replace with a new one.
(c) Fork piston ring	1	
<b>Left Fork Leg Only:</b>		
(8) Lower stop ring	1	Remove them from the fork piston.
(9) Oil lock valve	1	
(10) Oil lock valve spring	1	
(11) Spring seat	1	
(12) Upper stop ring	1	
(13) Fork piston/rebound spring	1	Remove them from the inner fork tube.
(14) Fork piston ring	2	Do not remove them, unless it is necessary to replace them with new ones. Anti dive case disassembly: (page 12-16)
(15) Oil seal	1	Remove them from the fork tube.
(16) Back-up ring	1	
(17) Slider bushing	1	
(18) Fork tube bushing	1	

# Fork Assembly

'89 - '90, '94 - '96 shown:

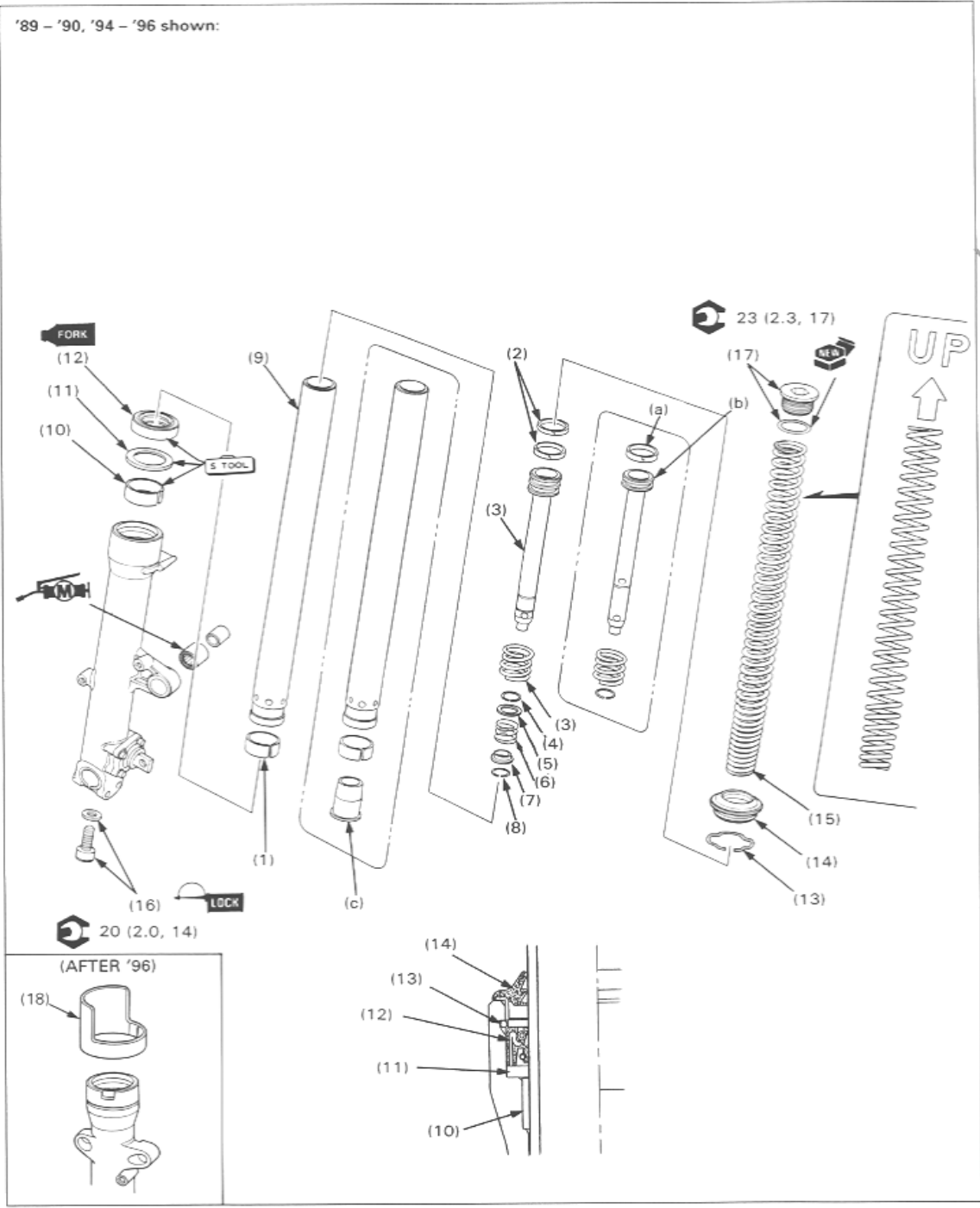

NOTE

- After assembling the fork legs, install each fork leg onto the steering stem first, then torque the fork cap bolt and torque the top bridge pinch bolt.
- Install the back-up ring with its chamfered surface side facing down.
- Coat a new oil seal with the recommended fork oil and install with seal mark facing up.

Requisite Service

- Fork installation (page 12-10)

Procedure	Q'ty	Remarks
<b>Assembly Order</b>		
(1) Fork tube bushing	1	Install the bushing onto the fork tube.
<b>Left Fork Leg Only:</b>		
(2) Fork piston ring	2	Apply fork oil to the rings.
(3) Fork piston/rebound spring	1	Install them into the inner fork tube.
(4) Upper stop ring	1	Install them onto the fork piston.
(5) Spring seat	1	
(6) Oil lock valve spring	1	
(7) Oil lock valve	1	
(8) Lower stop ring	1	
<b>Right Fork Leg Only:</b>		
(a) Fork piston ring	1	Apply fork oil to the rings.
(b) Fork piston	1	Install them into the inner fork tube.
(c) Oil lock piece	1	
(9) Fork tube	1	<ul style="list-style-type: none"> <li>• Drive them into the slider with special tools used for fork seal installation.</li> <li>• Wrap vinyl tape to the edge of the fork tube to prevent damage to the oil seal lips. Install the oil seal with mark facing up.</li> <li>• Use fork seal driver (07947 – KA50100) and attachment, 41 mm I.D. (07947 – KF00100) for fork seal installation.</li> </ul>
(10) Slider bushing	1	
(11) Back-up ring	1	
(12) Oil seal	1	
(13) Stop ring	2	<p><b>CAUTION:</b></p> <ul style="list-style-type: none"> <li>• Do not scratch the fork tube sliding surface.</li> </ul>
(14) Dust seal	1	Pour in the fork oil to the specified level before the fork spring installing.
(15) Fork spring	1	Tapered end must face toward the bottom.
(16) Socket bolt/washer	1	<p><b>CAUTION:</b></p> <ul style="list-style-type: none"> <li>• Be careful not to cross-thread the fork cap bolt.</li> <li>• Install the new O-ring onto the fork cap bolt and apply fork oil to the O-ring.</li> <li>• Screw in the bolt, but do not tighten yet.</li> </ul>
(17) Fork cap bolt/O-ring	1	
(18) Fork protector	1	(After '96)

## Anti-dive Case Disassembly/Assembly

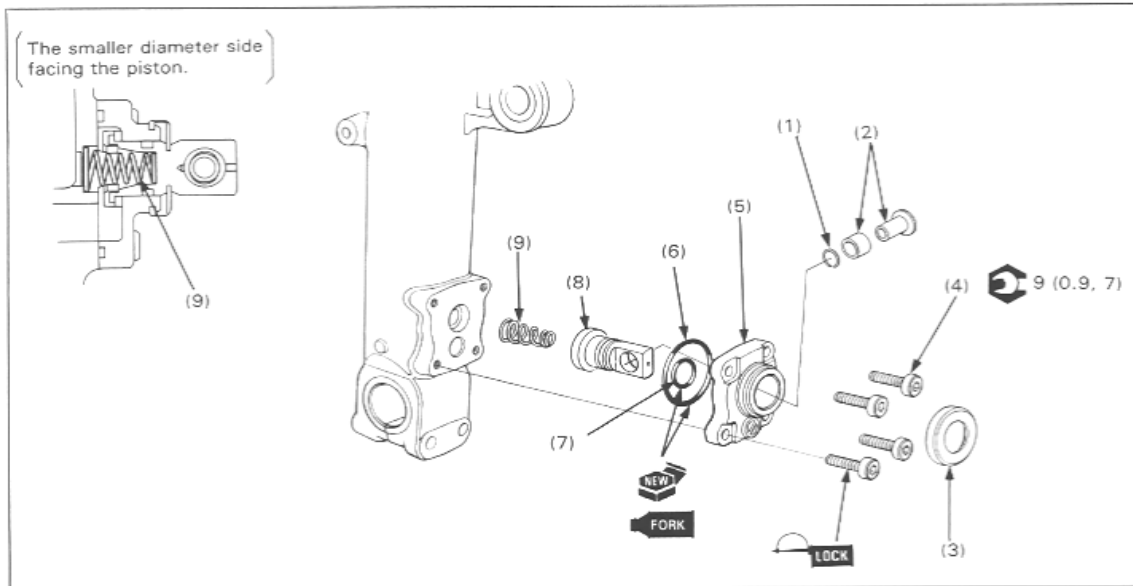

**WARNING**

- Anti-dive case is under spring pressure. Use care when removing the case to keep it from becoming projectiles.

### Requisite Service

- Fork oil draining

Procedure	Q'ty	Remarks
<b>Disassembly Order</b>		Assembly is in the reverse order of the disassembly.
(1) Stop ring	1	
(2) Pivot collar	2	
(3) Rubber boot	1	At installation: Install the boot lips onto the piston groove securely.
(4) Socket bolt	4	At installation: Apply locking agent to the threads.
(5) Case cover	1	
(6) O-ring	1	At installation: Apply fork oil to the O-ring.
(7) Piston seal	1	
(8) Anti-dive piston	1	
(9) Spring	1	At installation: Tapered end faces the cover.

**Needle Bearing Replacement**

Remove the pivot collar.  
 Check the needle bearing for wear or damage.  
 Replace it if necessary.

Remove the needle bearing using a hydraulic press with a special tool.

**S TOOL**

(Except U.S.A.)  
 Spherical Bearing Driver                    07946—KA30200

(U.S.A. Only)  
**Removal:**  
 Bearing Driver C.                            07945—3710300  
 Attachment, 25 mm I.D.                07746—0030200

**Installation:**  
 Driver    07749—0010000  
 Attachment, 24 x 26 mm                07746—0010700

Install a new needle bearing in the reverse order of removal.

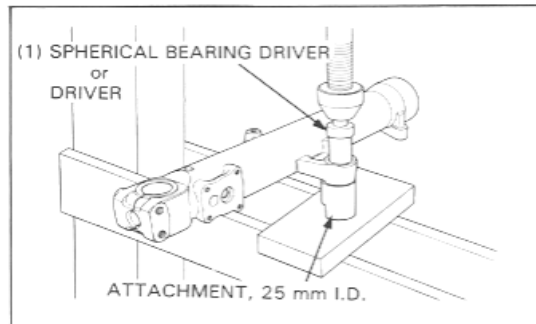

Turn Signal Cancel Control Unit (Angle Sensor) Removal/Installation ('89 - '90, '94 - '96)

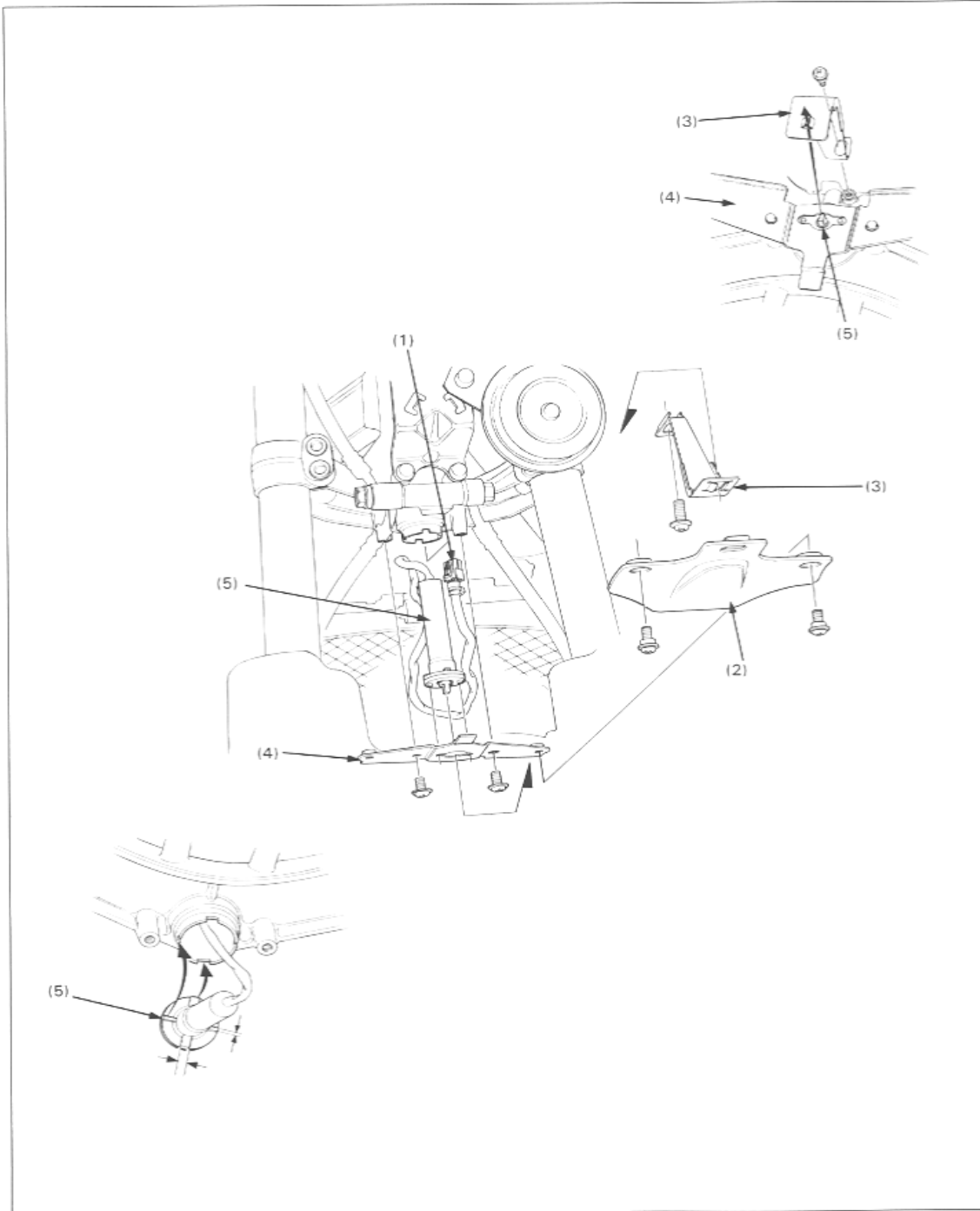

NOTE

• The unit inspection is refer to 18-17.

Requisite Service

- Handlebar covers removal (Section 2).

Procedure		Q'ty	Remarks
<b>Removal Order</b>			
(1)	Cancel control unit connector	1	Disconnect the 6P-White connector on the left handlebar.
(2)	Angle sensor cover	1	Remove it by removing the screw.
(3)	Angle sensor retainer	1	
(4)	Angle sensor holding plate	1	
(5)	Angle sensor	1	
<b>Installation Order</b>			
(5)	Angle sensor	1	Install the sensor, aligning the tabs with the steering stem's grooves on each side.
(4)	Angle sensor holding plate	1	Install the plate with the cover hook facing forward.
(3)	Angle sensor retainer	1	Install the retainer, aligning the hole with the boss of the angle sensor securely.
(2)	Angle sensor cover	1	Install the angle sensor cover, aligning the holding plate's hook with the cover hole.
(1)	Cancel control unit connector	1	Connect the 6P-White connector onto the turn signal switch connector.

## Steering Stem Removal

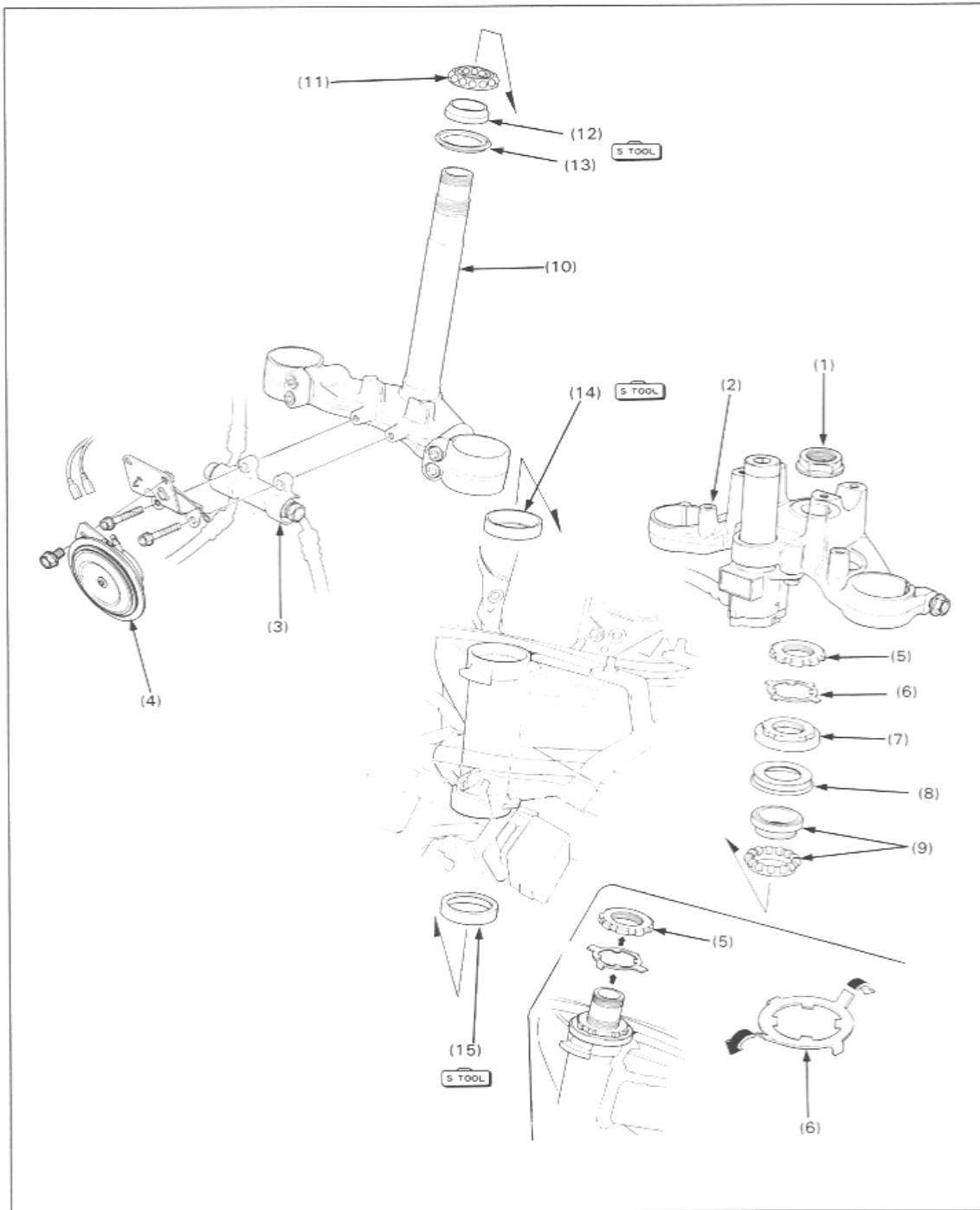

12-20

NOTE

- Replace each bearing and bearing race as a set.
- Do not reuse the lock washer.

Requisite Service

- Handlebar removal (page 12-4)
- Fork removal (page 12-10)
- Front wheel removal (page 12-6)
- Angle sensor removal (page 12-18)

Procedure	Q'ty	Remarks
<b>Removal Order</b>		
(1) Steering stem nut	1	
(2) Fork top bridge	1	
(3) Brake hose 3 way joint	1	By removing the mounting bolts.
(4) Horn	1	By removing the attaching bolt.
(5) Lock nut	1	Straighten the longer side lock washer tabs.
(6) Lock washer	1	Straighten the shorter side lock washer tabs.
(7) Bearing adjusting nut	1	Use steering stem socket (07916-3710100)
(8) Dust seal (upper side)	1	
(9) Upper bearing/inner race	1	
(10) Steering stem	1	Remove it from the frame.
(11) Lower bearing	1	Remove it from the stem.
(12) Lower bearing inner race	1	
(13) Dust seal (lower side)	1	
(14) Upper outer race	1	Use ball race remover (07946-MB00000) for upper race removal.
(15) Lower outer race	1	Use race bearing remover (07946-3710500) for lower race removal.

## Steering Stem Installation

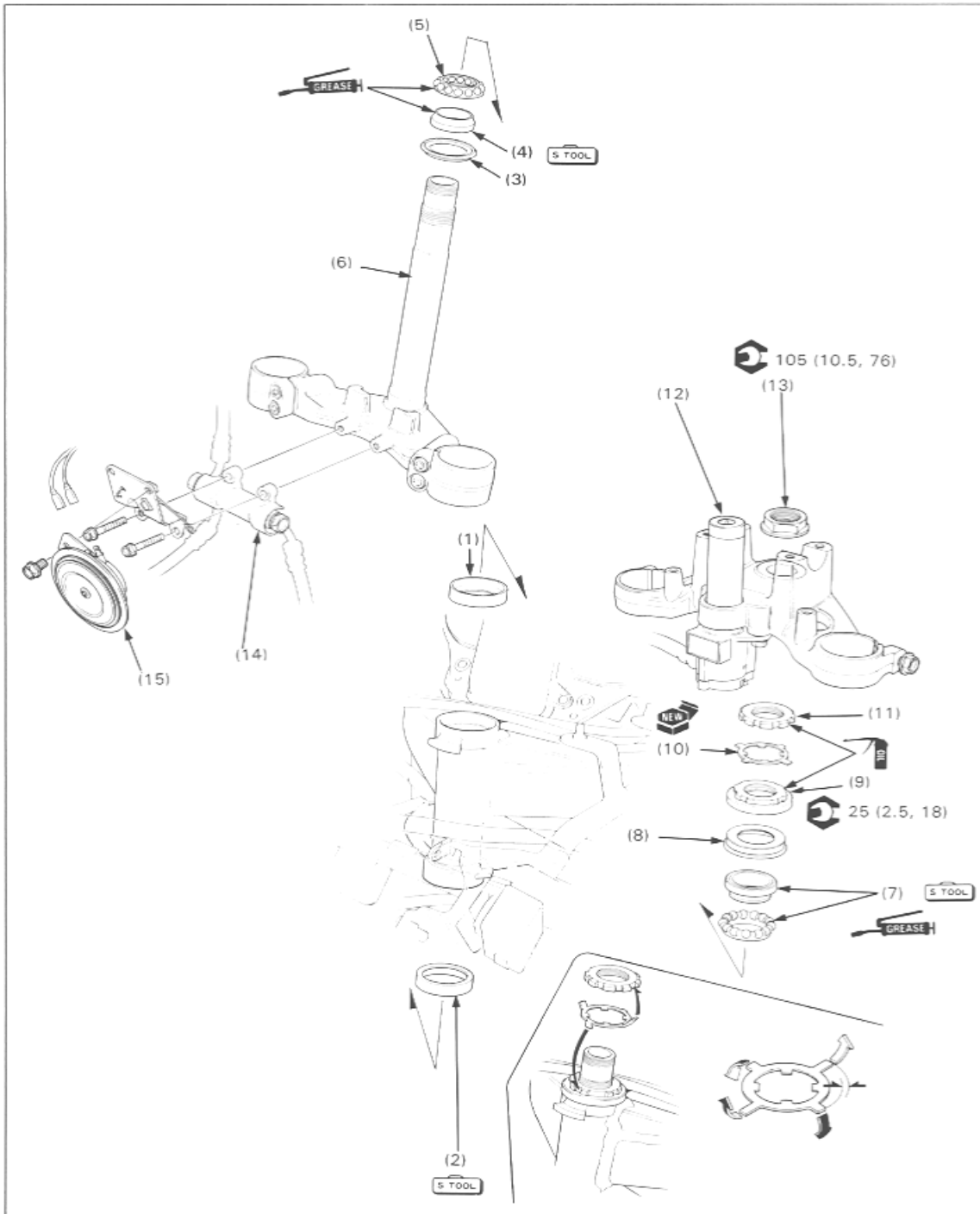

12-22

NOTE

- Replace each bearing and bearing race as a set.
- Do not reuse the lock washer.

Requisite Service

- Check the steering head bearing preload after installing.
- Handlebar installation (page 12-4)
- Fork installation (page 12-10)
- Front wheel installation (page 12-6)
- Angle sensor installation (page 12-18)

Procedure		Q'ty	Remarks
<b>Installation Order</b>			
(1)	Upper outer race	1	Use attachment, 42 x 47 mm (07746-0010300) and driver (07749-0010000) for upper race installation.
(2)	Lower outer race	1	
(3)	Dust seal (lower side)	1	Use attachment, 52 x 55 mm (07746-0010400) and driver (07749-0010000) for lower race installation.
(4)	Lower bearing inner race	1	
(5)	Lower bearing	1	Use driver (07946-MB00000) and a press for lower inner race installation.
(6)	Steering stem	1	
(7)	Upper bearing/inner race	1	Align the tabs with grooves in the adjustment nut and bend two opposite tabs (shorter) down into the grooves.
(8)	Dust seal	1	
(9)	Bearing adjustment nut	1	Finger tighten the lock nut all the way and bend the lock washer tabs (longer) up into the lock nut grooves.
(10)	Lock washer	1	
(11)	Lock nut	1	
(12)	Fork top bridge	1	By mounting bolts.
(13)	Steering stem nut	1	
(14)	Brake hose 3 way joint	1	By attaching bolt.
(15)	Horn	1	

---

## 13. Rear Wheel/Suspension

Service Information	13-1	Shock Absorber Disassembly/ Assembly	13-7
Troubleshooting	13-1	Swingarm Removal/Installation	13-8
Rear Wheel Removal/Installation	13-2	Swingarm Disassembly/Assembly	13-10
Rear Wheel Disassembly/Assembly	13-4		
Shock Absorber Removal/Installation	13-6		

### Service Information

**▲ WARNING**

- Any attempt to mount auto-mobile tires on a motorcycle rim may cause the tire bead to separate from the rim with enough explosive force to cause serious injury or death.

- When servicing the rear wheel, support the motorcycle securely with a center stand or other support under the engine.
- Refer to the section 14 for brake system information.
- Use only tires marked "TUBELESS" and tubeless valves on rims marked "TUBELESS TIRE APPLICABLE".
- Use only genuine Honda bolts and nuts on all suspension, swingarm and shock absorber mounting locations.

### Troubleshooting

#### Soft Suspension

- Weak spring
- Oil leakage from damper unit
- Incorrect preload adjuster adjustment

#### Hard Suspension

- Incorrectly mounted suspension components
- Faulty swingarm pivot
- Incorrect preload adjuster adjustment
- Bent damper rod
- Damaged swingarm pivot bearings

**13**

### Rear Wheel Removal/Installation

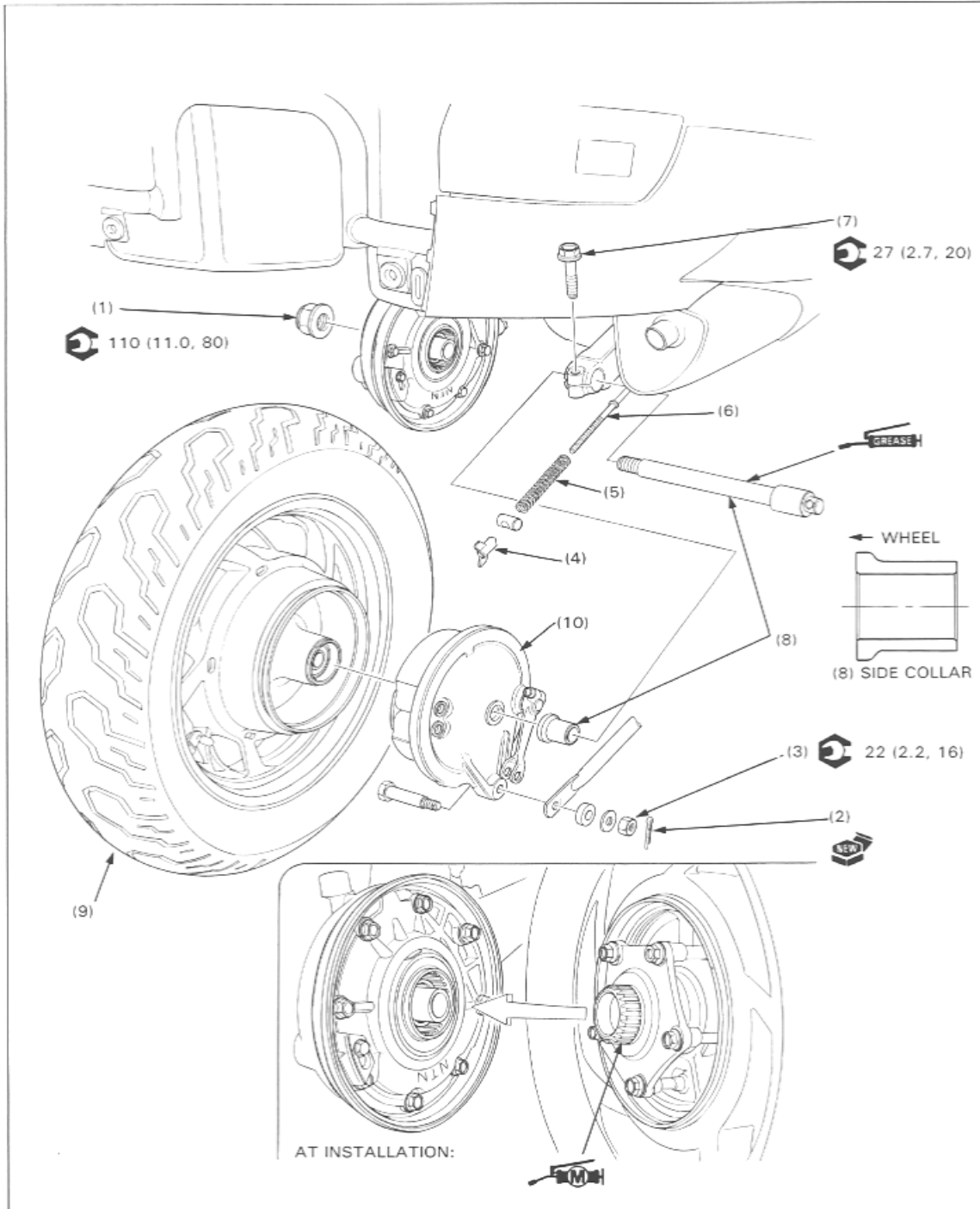

NOTE

- Apply multipurpose NLGI No. 2 grease (Molybdenum disulfide additive) to the drive flange and the ring gear engagement splines.
- Do not add more than 70 grams to the wheel balance weight.
- Thin coat clean grease to the rear axle before installation.
- After reassembly, check rear brake free play and adjust if necessary.

Requisite Service

- Place the motorcycle on its center stand
- Rear fender removal (Section 2)

Procedure	Q'ty	Remarks
<b>Removal Order</b>		Installation is in the reverse order of removal.
(1) Axle nut	1	
(2) Cotter pin	1	
(3) Torque link nut	1	Disconnect the torque link from the brake panel.
(4) Brake adjusting nut	1	
(5) Return spring	1	
(6) Brake rod	1	Disconnect the brake rod from the brake panel.
(7) Axle pinch bolt	1	
(8) Rear axle/side collar	1	
(9) Rear wheel assembly	1	• At installation: Engage the rear wheel with the final drive case, making sure the splines are correctly aligned. • Disassembly: (page 13-4)
(10) Rear brake assembly	1	Disassembly: (page 14-8)

Remove the rear wheel and final driven flange as an assembly.

NOTE

- In case that the final driven flange tend to stay in the final drive spline, push the driven flange into the wheel by the suitable tool.

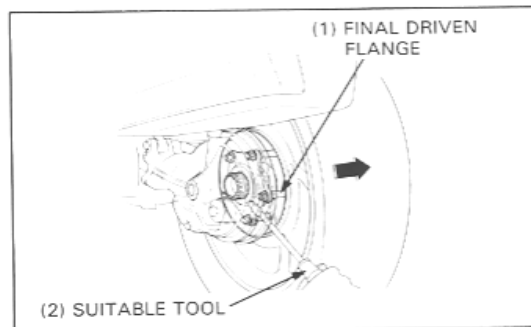

### Rear Wheel Disassembly/Assembly

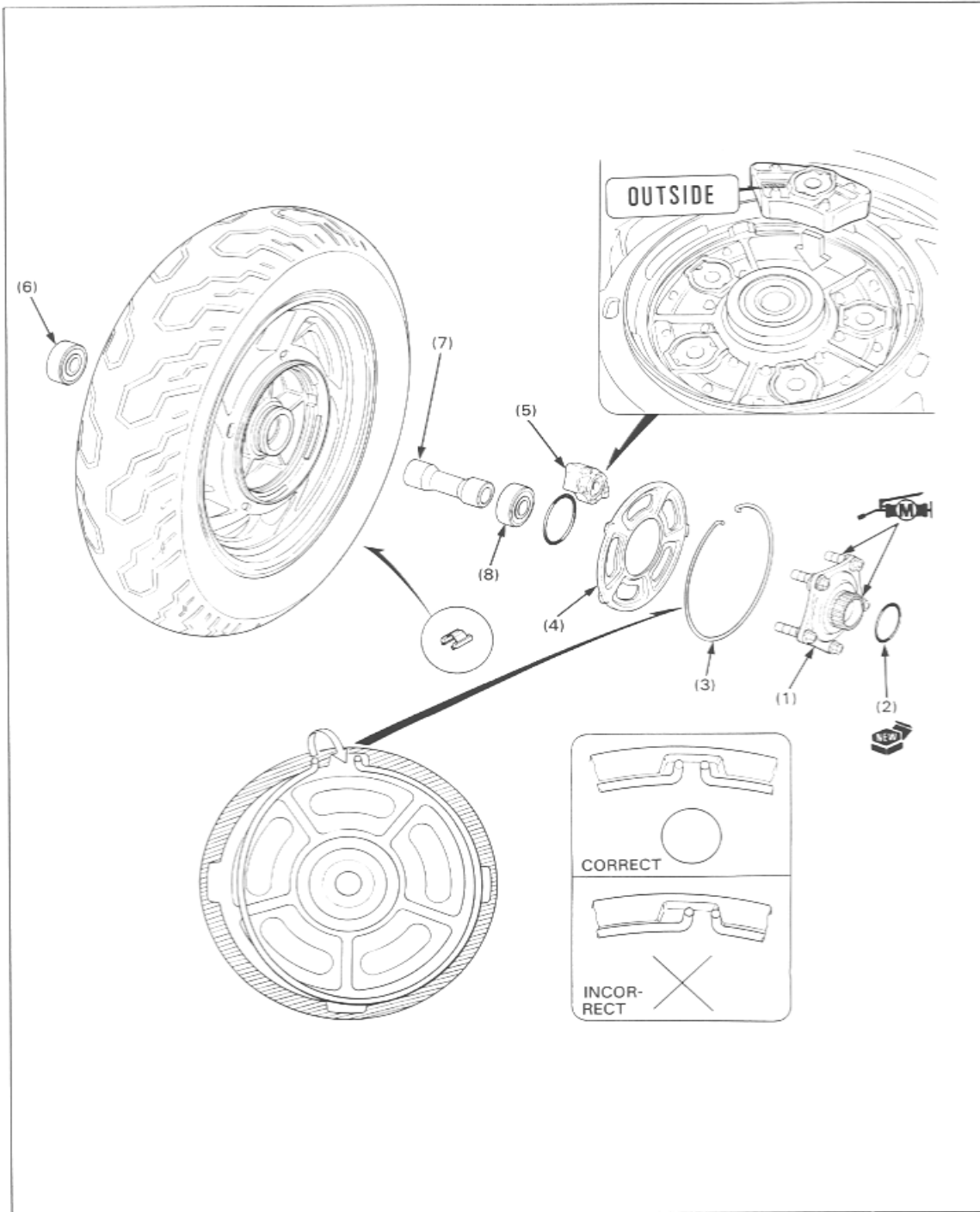

## NOTE

- Do not add more than 70 grams to the wheel balance weight.
- Replace the driven damper rubbers as a set.
- Replace the wheel bearings in pairs.
- Refer to the Common Service Manual, section 1 for wheel bearings replacement.

## Requisite Service

- Rear wheel removal (page 13-2)

Procedure		Q'ty	Remarks
<b>Disassembly Order</b>			
(1)	Final driven flange assembly	1	Assembly is in the reverse order of the disassembly. Remove the driven flange from the wheel.
(2)	O-ring	1	
(3)	Stop ring	1	Check the stop ring at the another locking cutouts, seated onto the groove after the installation.
(4)	Retaining plate	1	NOTE: • Install the rubber with the "OUTSIDE" mark is facing out.
(5)	Damper rubber assembly	6	
(6)	Left wheel bearing (6304C3 UU)	1	At installation: Drive in the right bearing first, then the distance collar, then install the left bearing.
(7)	Distance collar	1	
(8)	Right wheel bearing (6204 UU)	1	

## Shock Absorber Removal/Installation

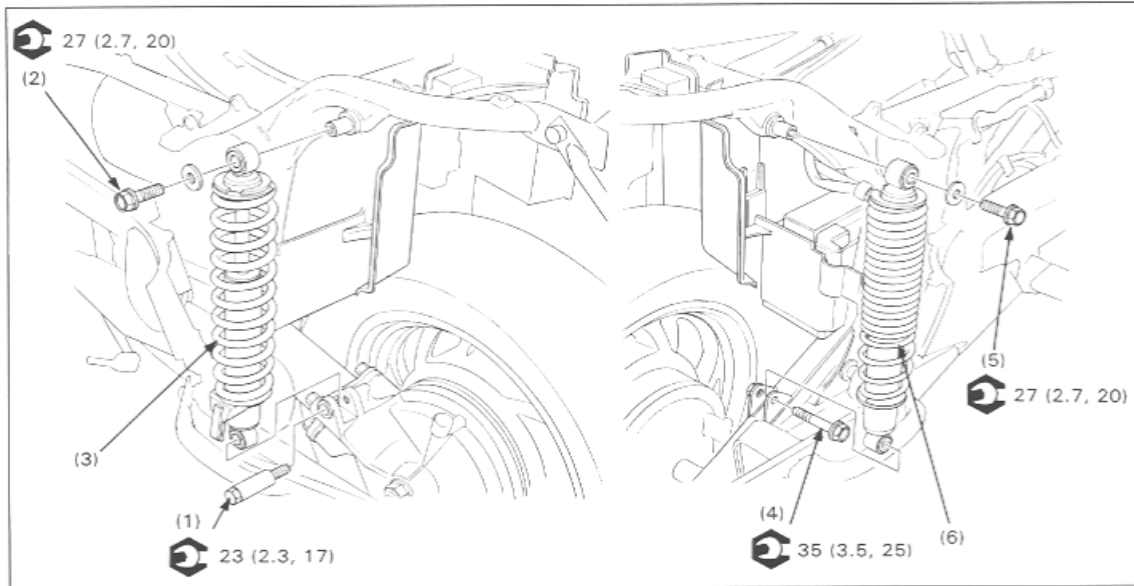

**NOTE**

- Using the floor jack or other adjustable support under the final drive to relieve stress for ease of left shock absorber lower mounting bolt removal/installation.
- Adjust the left shock absorber to the softest position for disassembly.

**Requisite Service**

- Place the motorcycle on its center stand
- Trunk assembly removal (Section 2)

Procedure	Q'ty	Remarks
<b>Removal Order</b>		Installation is in the reverse order of removal.
(1) Left lower mounting bolt	1	At installation: Apply engine oil to the sliding surface for ease of bolt installation.
(2) Left upper mounting bolt	1	
(3) Left shock absorber	1	Disassembly: (page 13-7)
(4) Right lower mounting bolt	1	
(5) Right upper mounting bolt	1	
(6) Right shock absorber	1	Disassembly: (page 13-7)

## Shock Absorber Disassembly/Assembly

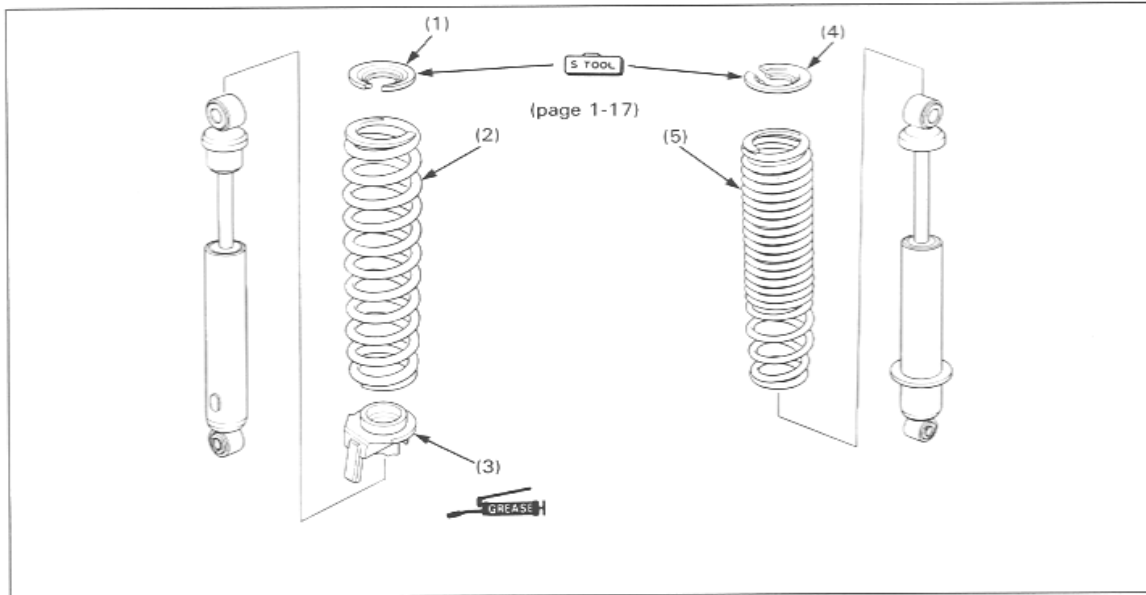

## NOTE

- Adjust the left shock absorber to the softest position for disassembly.
- Refer to the Common Service Manual, section 19 for shock absorber dis/assembly.

## Requisite Service

- Rear shock absorber removal (page 13-6)

Procedure	Q'ty	Remarks
<b>Disassembly Order</b> Left side: (1) Upper seat	1	Assembly is in the reverse order of the disassembly.
(2) Coil spring (3) Preload adjuster plate	1 1	Compress the shock absorber using a shock absorber compressor (07959-3290001) and attachment (07959-MB10000).
Right side: (4) Upper seat	1	Compress the shock absorber using a shock absorber compressor and attachment.
(5) Coil spring	1	Install the spring with the tapered end toward the bottom.

# Swingarm Removal/Installation

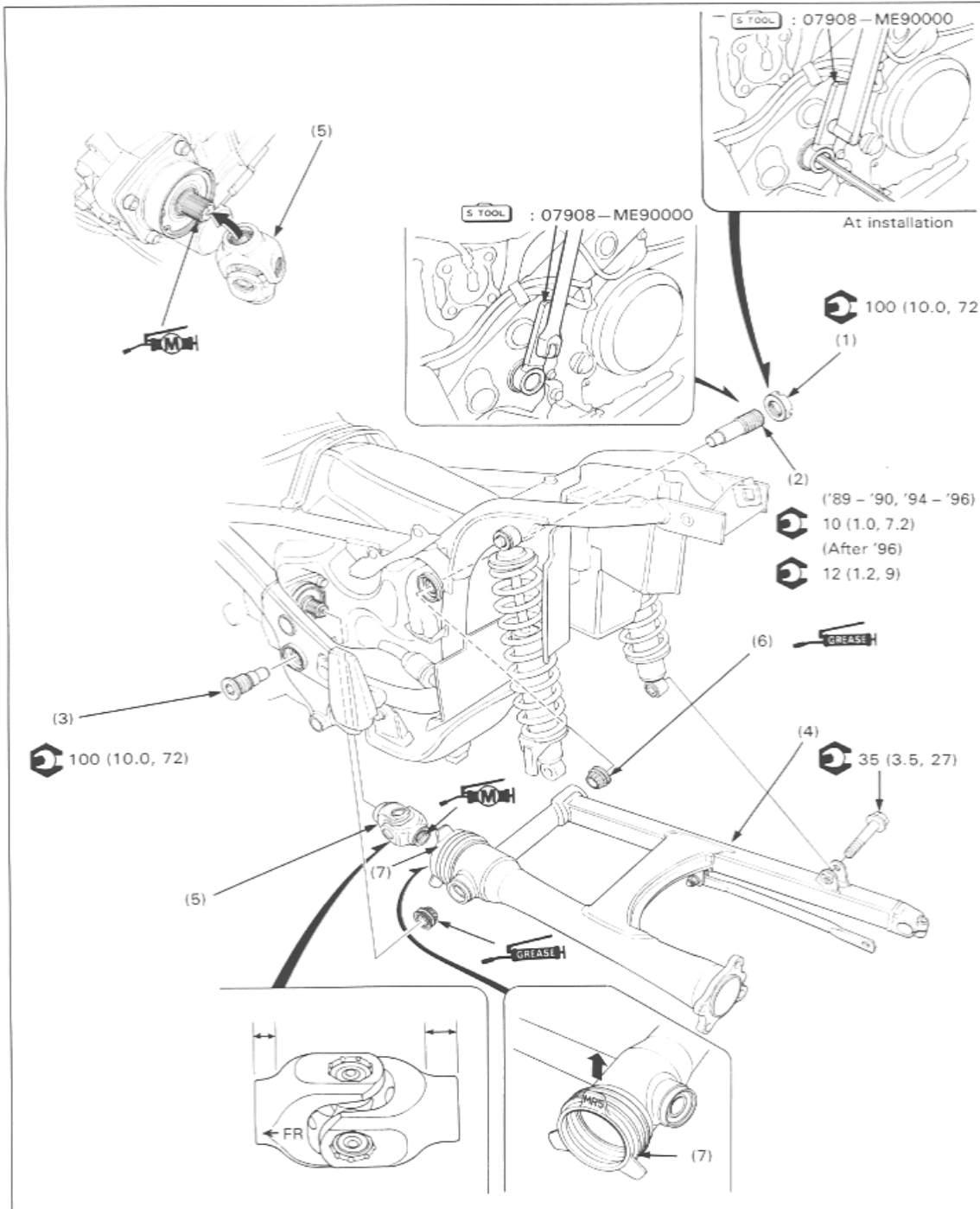

NOTE

- It is not necessary to remove the trunk assembly to remove the swingarm.
- Replace the pivot bearing and outer race as a set.
- Replace the grease retainer plate whenever it is removed.

Requisite Service

- Place the motorcycle on its center stand
- Muffler removal (Section 2)
- Final drive case removal (page 11-2)

Procedure		Q'ty	Remarks
<b>Removal Order</b>			
(1)	Right pivot lock nut	1	Using a lock nut wrench (07908 – ME90000)
(2)	Right pivot bolt	1	
(3)	Left pivot bolt	1	
(4)	Swingarm assembly	1	Remove the swingarm from the frame.
(5)	Universal joint	1	Remove the joint from the engine or swingarm.
(6)	Dust seal/pivot bearing	2	• The pivot bearing has a built-in dust seal. • Bearing outer race replacement: (page 13-11)
(7)	Rubber boot	1	Swingarm disassembly: (page 13-10)
<b>Installation Order</b>			
(7)	Rubber boot	1	Install the rubber boot onto the swingarm with the "MRS" mark facing up.
(6)	Dust seal/pivot bearing	2	Apply grease to the bearing and dust seal lips.
(5)	Universal joint	1	Install the universal joint with "FR" mark facing forward. Engage the universal joint with the output shaft, making sure the splines are correctly aligned.
(4)	Swingarm assembly	1	The rubber boot fitting onto the engine securely.
(3)	Left pivot bolt	1	• Apply clean grease to the bolt's tips. • Making sure the swingarm moving up and down smoothly.
(2)	Right pivot bolt	1	
(1)	Right pivot lock nut	1	Tighten the lock nut using a lock nut wrench, while holding the pivot bolt.

### Swingarm Disassembly/Assembly

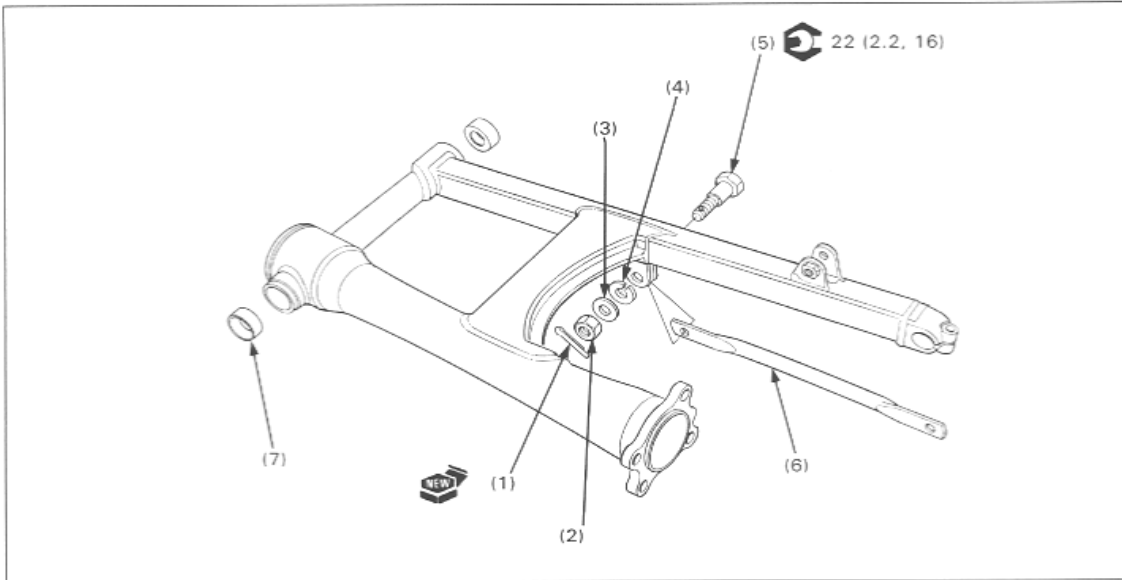

**Requisite Service**

- Swingarm removal (page 13-8)

Procedure	Q'ty	Remarks
<b>Disassembly Order</b>		Assembly is in the reverse order of the disassembly.
(1) Cotter pin	1	
(2) Mounting nut	1	
(3) Plain washer	1	
(4) Cushion rubber	1	
(5) Torque link bolt	1	
(6) Torque link	1	
(7) Bearing outer race	2	Replacement: (page 13-11)

### Pivot Bearing Race Replacement

Punch or drill an appropriate hole into a grease retainer plate. Remove the outer race on the other side with grease retainer plate. Remove the other race with its grease retainer.

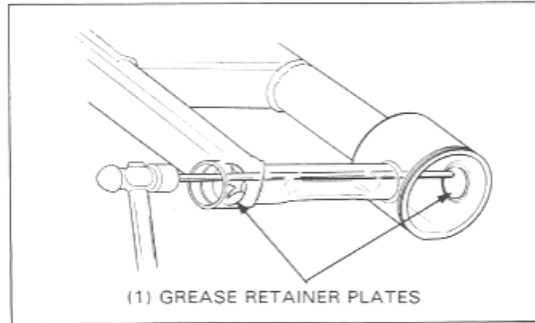

#### NOTE

- Replace the bearing inner and outer races as a set. Replace the grease retainer plate whenever it is removed.

Install new grease retainer plates and drive new bearing outer races into the swingarm pivot.



**Driver**  
**Attachment, 32 x 35 mm**

**07749-0010000**  
**07746-0010100**

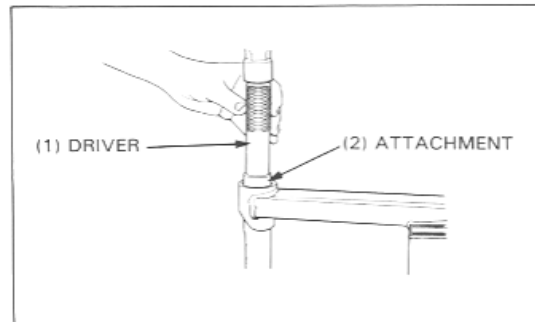

# 14. Brake System

Service Information	14-1	Front Brake Caliper Removal/Disassembly	14-6
Troubleshooting	14-1	Rear Brake Disassembly/Assembly	14-8
Front Brake Pad Replacement	14-2	Rear Brake Pedal and Linkage Removal/Installation	14-9
Front Master Cylinder Disassembly/Assembly	14-4		

## Service Information

### ▲ WARNING

- A contaminated brake disc or pad reduces stopping ability.
- Mixing incompatible fluids will impair braking efficiency.
- Foreign materials can clog the system, causing a reduction or complete loss of braking ability.
- Always reinstall the brake pads (or shoes) in their original positions to prevent loss of braking efficiency.
- Grease on the brake linings will reduce stopping ability and may cause brake failure.

- Bleed the hydraulic system if it has been disassembled or if the brake feels spongy.
- Do not allow foreign material to enter the system when filling the reservoir.
- Avoid spilling brake fluid on painted, plastic or rubber parts. Place a rag or shop towel over these parts whenever the system is serviced.
- Always check the brake operation before riding the motorcycle.

## Troubleshooting

### Front Brake:

#### Brake Lever Soft or Spongy

- Air bubbles in the hydraulic system
- Leaking hydraulic system
- Contaminated brake pad/disc
- Worn caliper piston seal
- Worn master cylinder piston seal
- Worn brake pad/disc
- Contaminated caliper
- Caliper not sliding properly
- Low fluid level
- Clogged fluid passage
- Warped/deformed brake disc
- Sticking/worn caliper piston
- Sticking/worn master cylinder piston
- Contaminated master cylinder
- Bent brake lever

#### Brake Lever Hard

- Clogged/restricted brake system
- Sticking/worn caliper piston
- Caliper not sliding properly
- Clogged/restricted fluid passage
- Worn caliper piston seal
- Sticking/worn master cylinder piston
- Bent brake lever

#### Brake Grab or Pull to One Side

- Contaminated brake pad/disc
- Misaligned wheel
- Clogged/restricted brake/hose joints
- Warped/deformed brake disc
- Caliper not sliding properly

#### Brakes Drag

- Contaminated brake pad/disc
- Misaligned wheel
- Worn brake pad/disc
- Warped/deformed brake disc
- Caliper not sliding properly

### Rear Brake:

#### Poor Brake Performance

- Improperly adjusted brake
- Worn brake linings
- Worn brake drum
- Worn brake cam
- Improperly installed brake linings
- Brake linkage needs lubrication
- Contaminated brake linings
- Contaminated brake drum
- Worn brake shoes at cam contact areas
- Improper engagement between brake arm and cam-shaft serrations

#### Brake Pedal Hard or Slow to Return

- Worn/broken return spring
- Improperly adjusted brake
- Shoes sticking to brake drum due to contamination
- Worn brake shoes at cam contact areas
- Brake linkage needs lubrication
- Worn brake cam
- Improperly installed brake linings

#### Brake Squeaks

- Worn brake linings
- Worn brake drum
- Contaminated brake linings
- Contaminated brake drum

14

14-1

# Front Brake Pad Replacement

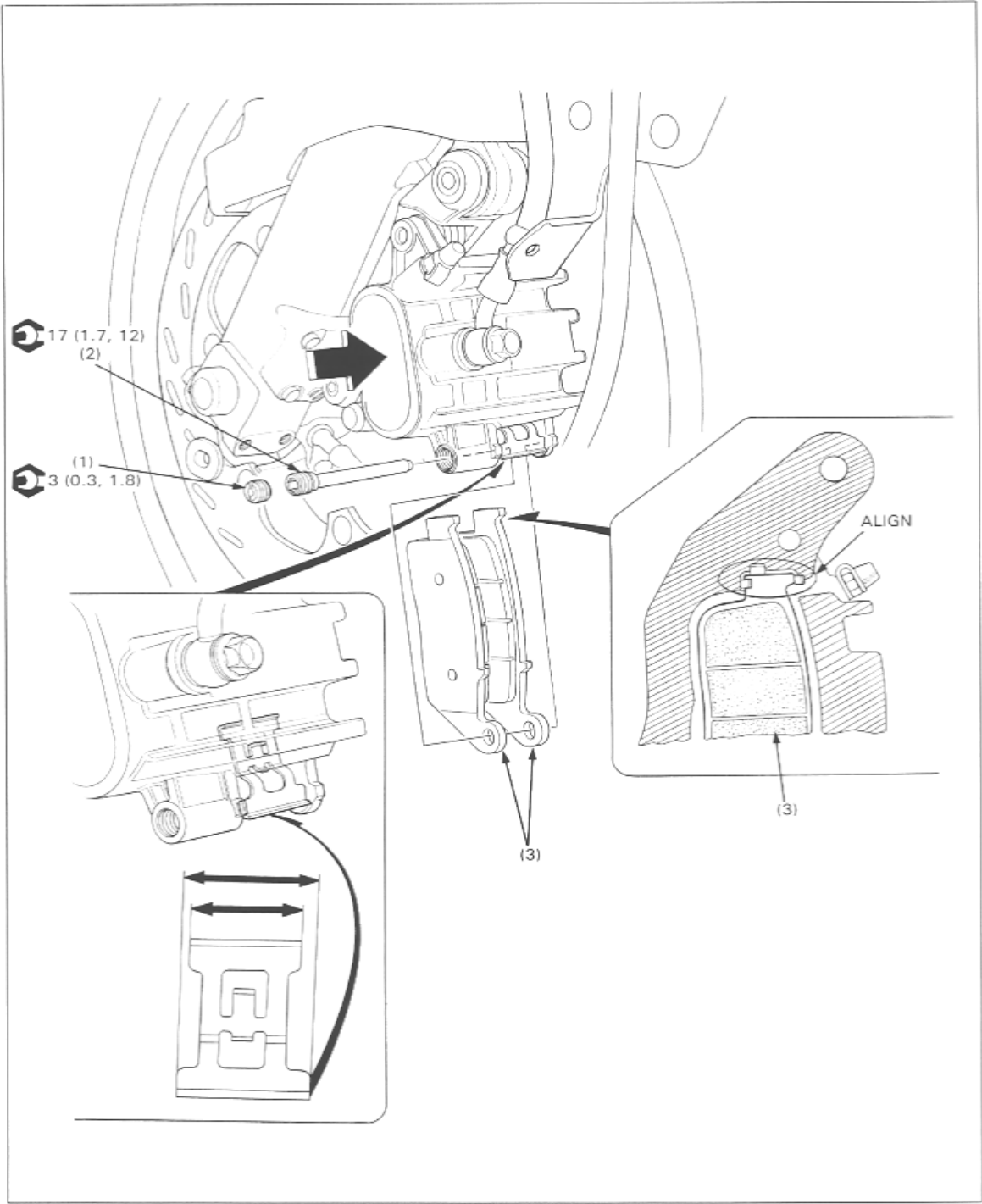

**▲ WARNING**

- Do not get grease on the brake disc or stopping power will be reduced.
- Discard contaminated pads and clean a contaminated disc with a high quality brake degreasing agent.
- Check the brake system by applying the brake after pad replacement.

**NOTE**

- Operate the brake lever to seat the caliper pistons against the pads after the pad replacement.
- The brake pad replacement can be serviced without disconnecting the hydraulic system.
- Always replace the brake pads in pairs to assure even disc pressure.

**Requisite Service**

- Caliper cover and disc cover removal (Section 2)

Procedure		Q'ty	Remarks
<b>Removal Order</b>			
(1)	Pad pin plug	1	Loosen the pad pin.
(2)	Pad pin	1	Push the pistons all the way in to provide clearance for new brake pads.
(3)	Brake pad	2	Pull the pad pin out of the caliper and remove the pads.
<b>Installation Order</b>			
(3)	Brake pad	2	<ul style="list-style-type: none"> <li>• Position the pad spring in the caliper as shown.</li> <li>• Position the pad onto the pad retainer in the caliper as shown.</li> </ul>
(2)	Pad pin	1	<ul style="list-style-type: none"> <li>• Apply a thin coat clean grease to the threads.</li> </ul>
(1)	Pad pin plug	1	



**▲ WARNING**

- Check the brake system by applying the brake after the air bleeding.

**CAUTION**

- Avoid spilling fluid on painted, plastic, or rubber parts. Place a rag over these parts whenever the system is serviced.
- When removing the oil bolt, cover the end of the clutch hose to prevent contamination.  
Do not allow the foreign material to enter the system.
- Do not allow the lips of the cups to turn inside and be certain the snap ring is firmly seated in the groove.

**NOTE**

- The master cylinder piston, cups and spring must be installed as a set.
- Use only DOT 4 brake fluid from a sealed container.
- Refer to The Common Service Manual, Section 17 for dis/assembly.

**Requisite Service**

- Front brake fluid draining/air bleeding
- Brake master cylinder removal (page 12-2)

Procedure	Q'ty	Remarks
<b>Disassembly Order</b>		
(1) Brake hose bolt/hose	1	Disconnect the brake switch wire from the connector and remove the master cylinder holder. Remove the screws and the cover.  NOTE: • Do not remove the piston cup from the piston.
(2) Sealing washer	2	
(3) Master cylinder assembly	1	
(4) Master cylinder cover	1	
(5) Diaphragm plate	1	
(6) Diaphragm	1	
(7) Brake switch	1	
(8) Brake lever pivot bolt/nut	1	
(9) Brake lever	1	
(10) Piston boot	1	
(11) Snap ring	1	
(12) Master piston assembly	1	
(13) Primary cup/spring	1	
<b>Assembly Order</b>		
(13) Primary cup/spring	1	NOTE: • Install the primary cup and spring as an assembly as shown. • Install the spring with its small coil end toward the cup. Apply clean brake fluid (DOT 4). <b>CAUTION:</b> • Be certain the snap ring is firmly seated in the groove. <b>CAUTION:</b> • Be certain the boot is firmly in the groove.
(12) Master piston	1	Install it securely with the screw. Install it by the holder onto the handlebar (page 12-2). <b>CAUTION:</b> • Do not reuse the sealing washers.
(11) Snap ring	1	
(10) Piston boot	1	
(7) Brake switch	1	
(9) Brake lever assembly	1	
(8) Brake lever pivot bolt/nut	1	
(6) Diaphragm	1	
(5) Diaphragm plate	1	
(4) Master cylinder cover	1	
(3) Master cylinder	1	
(2) Sealing washer	2	
(1) Brake hose bolt/hose	1	



**▲ WARNING**

- Do not get grease on the brake disc or stopping power will be reduced.
- Discard contaminated pads and clean a contaminated disc with a high quality brake degreasing agent.
- Check the brake system by applying the brake after the air bleeding.

**CAUTION**

- Spilled brake fluid will damage painted, plastic, or rubber parts.

**Requisite Service**

- Caliper cover and disc cover removal (Section 2)
- Front brake fluid draining/air bleeding

Procedure	Q'ty	Remarks
<b>Disassembly Order</b>		
(1) Brake hose bolt/hose	1	Unhook the brake hose from the clamp.
(2) Sealing washer	2	
(3) Pad	2	(page 14-2)
(4) Caliper mounting bolt	2	NOTE: • Anti-dive piston bolt is on the left caliper.
(5) Brake caliper assembly	1	
(6) Pad spring	1	Separate the caliper from the bracket.
(7) Pad retainer	1	
(8) Pin bolt boot	1	
(9) Pivot boot	1	
(10) Caliper piston	2	
(11) Dust seal	2	<b>CAUTION:</b> • Be careful not to damage the piston sliding surface. • Do not reuse the removed seal.
(12) Piston seal	2	
<b>Assembly Order</b>		
(12) Piston seal	2	
(11) Dust seal	2	
(10) Caliper piston	2	NOTE: • Install with the dished ends toward the pad as shown.
(9) Pivot boot	1	Push into the groove firmly.
(8) Pin bolt boot	1	Push into the caliper firmly.
(7) Pad retainer	1	
(6) Pad spring	1	Assemble the caliper with the bracket.
(5) Brake caliper assembly	1	
(4) Caliper mounting bolt	2	NOTE: • Anti-dive piston bolt is on the left caliper.
(3) Pad	2	(page 14-2)
(2) Sealing washer	2	
(1) Brake hose bolt/hose	1	Route the brake hose onto the clamp as shown.

## Rear Brake Disassembly/Assembly

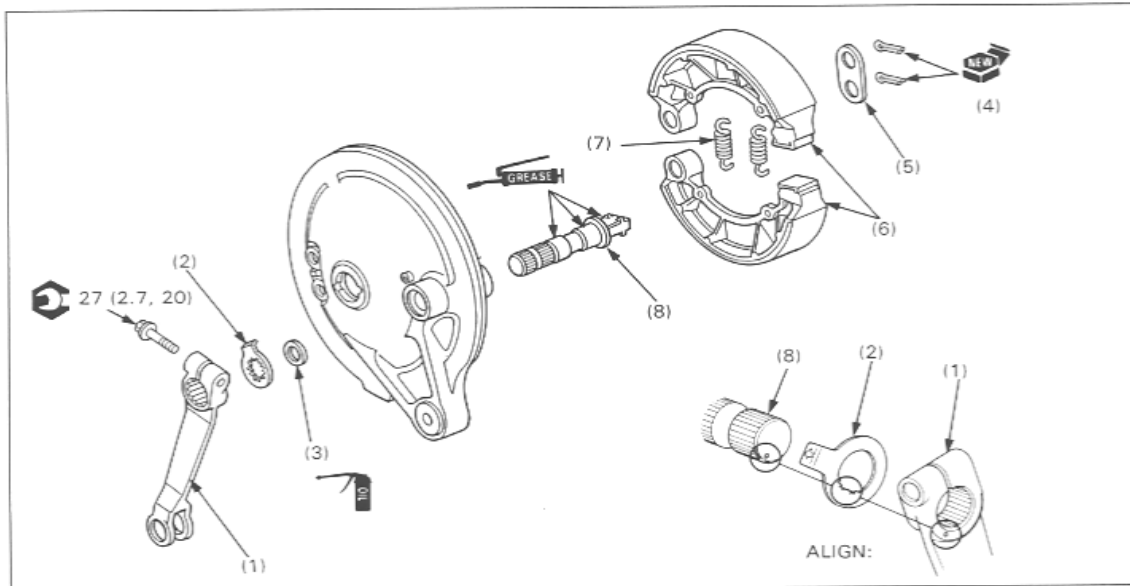

**WARNING**

- Do not get grease on the brake drum and shoes or stopping power will be reduced.
- Discard contaminated shoes and clean a contaminated drum with a high quality brake degreasing agent.

### Requisite Service

- Rear wheel removal (page 13-2)

Procedure	Q'ty	Installation Remarks
<b>Disassembly Order</b>		Assembly is in the reverse order of disassembly.
(1) Brake arm	1	Align the punch marks on the brake cam and arm.
(2) Wear indicator	1	Align the wide tooth with the wide groove in the brake cam.
(3) Felt seal	1	Apply clean oil to the felt seal.
(4) Cotter pin	2	Install with endless side facing out.
(5) Cotter pin plate	1	
(6) Brake shoes	2	
(7) Return spring	2	
(8) Brake cam	1	Apply clean grease to the sliding surface of the anchor pins and brake cam.

## Brake Pedal and Linkage Removal/Installation

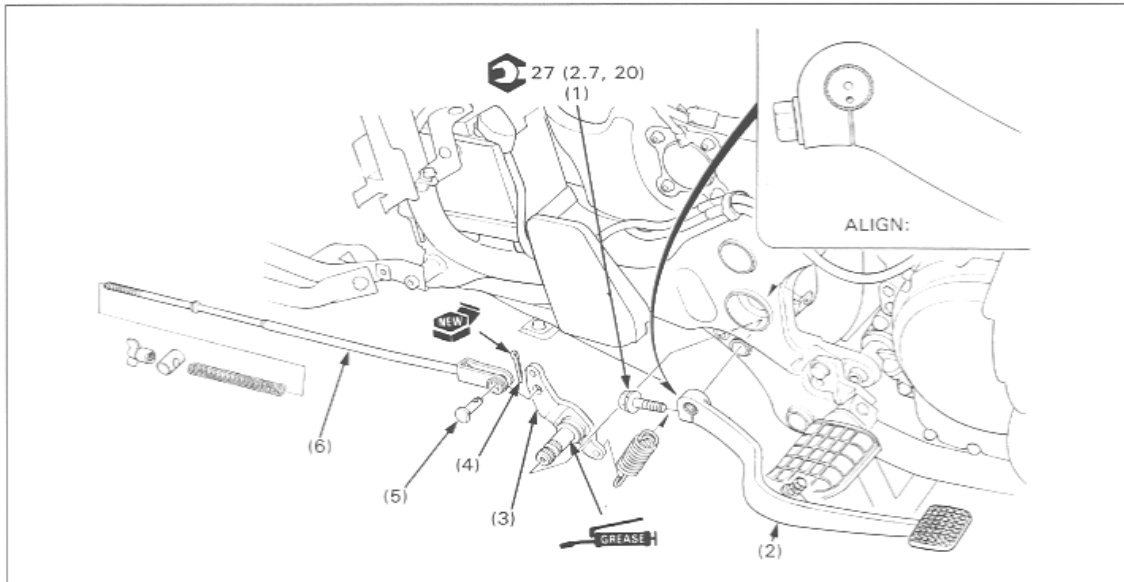

### Requisite Service

- Swingarm removal (page 13-8)

Procedure		Q'ty	Installation Remarks
<b>Removal Order</b>			Assembly is in the reverse order of removal.
(1)	Brake pedal pinch bolt	1	
(2)	Brake pedal	1	Align the punch mark on the shaft with the brake pedal slot.
(3)	Brake linkage & rod	1	Apply clean grease to the sliding surface of the shaft.
(4)	Cotter pin	1	
(5)	Joint pin	1	Assemble the joint pin and the shaft, aligning the cutout of the joint pin with the boss in the linkage shaft.
(6)	Brake rod	1	

# 15. Charging System/Alternator

Service Information	15-1	Charging System Inspection	15-4
System Location	15-2	Regulator/Rectifier	15-5
Troubleshooting	15-3	Alternator	15-7
Battery	15-4	Alternator Removal/Installation	15-8

## Service Information

### ▲ WARNING

- The battery gives off explosive gases; keep sparks, flames, and cigarettes away. Provide adequate ventilation when charging or using the battery in an enclosed space.
- The battery contains sulfuric acid (electrolyte). Contact with skin or eyes may cause severe burns. Wear protective clothing and a face shield.
  - If electrolyte gets on your skin, flush with water.
  - If electrolyte gets in your eyes, flush with water for at least 15 minutes and call a physician immediately.
- Electrolyte is poisonous. If swallowed, drink large quantities of water or milk and follow with milk of magnesia or vegetable oil and call a physician.
- **KEEP OUT OF REACH OF CHILDREN.**

- Always turn off the ignition switch before disconnecting any electrical component.

### CAUTION

- Some electrical components may be damaged if terminals or connectors are connected or disconnected while the ignition switch is ON and current is present.

- For extended storage, remove the battery, give it a full charge, and store it in a cool, dry place.
- For battery remaining in a stored motorcycle, disconnect the negative battery cable from the battery terminal.

### NOTE

- The maintenance free battery must be replaced when it reaches the end of its service life.

15

### CAUTION

- The battery caps should not be removed. Attempting to remove the sealing caps from the cells may damage the battery.

- Battery can be damaged if overcharged or undercharged, or if left to discharge for long periods. These same conditions contribute to shortening the "life span" of the battery. Even under normal use, the performance of battery deteriorates after 2–3 years.
- Battery voltage may recover after battery charging, but under heavy load, battery voltage will drop quickly and eventually die out. For this reason, the charging system is often suspected to be the problem. Battery overcharge often results from problems in the battery itself, which may appear to be an overcharge symptom. If one of the battery cells is shorted and battery voltage does not increase, the regulator/rectifier supplies excess voltage to the battery. Under these conditions, the electrolyte level goes down quickly.
- Before troubleshooting the charging system, check for proper use and maintenance of the battery. Check if the battery is frequently under heavy load, such as having the headlight and taillight ON for long periods of time without riding the motorcycle.
- The battery will self-discharge when the motorcycle is not in use. For this reason, charge the battery every two weeks to prevent sulfation from forming.
- Filling a new battery with electrolyte will produce some voltage, but in order to achieve its maximum performance, always charge the battery. Also, the battery life is lengthened when it is initial-charged.
- When checking the charging system, always follow the steps in the troubleshooting flow chart (page 15-3).
- For battery testing/charging, refer to section 22 of the Common Service Manual.
- For charging system location, see page 15-2.

15-1

## System Location

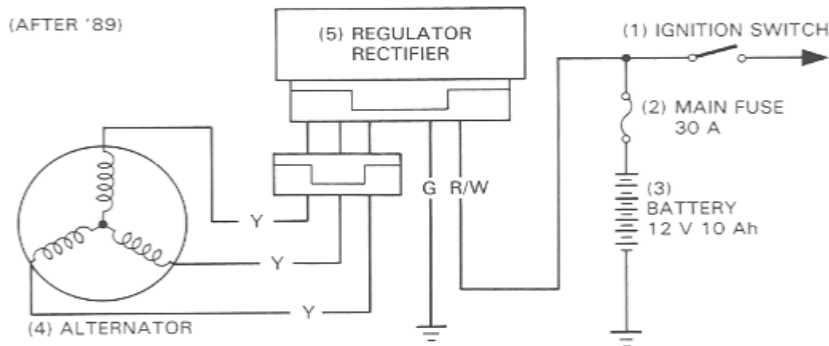
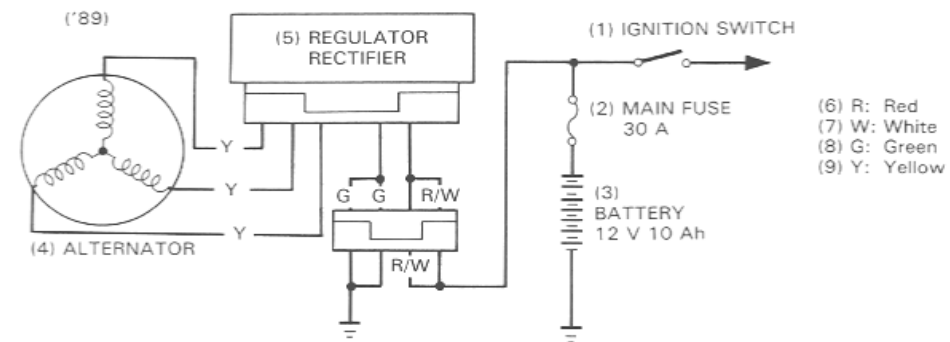
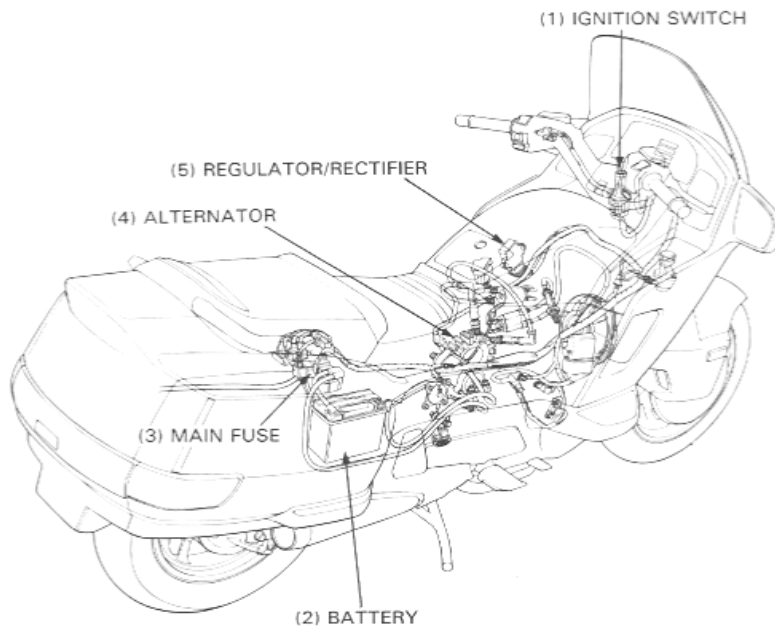

# Troubleshooting

**Battery Overcharging**  
 • Faulty regulator/rectifier

**Battery Undercharging**

**NOTE**

• In order to obtain accurate test readings when charging system, the battery must be fully charged and in good condition. See Common Service Manual section 22 for check the battery condition.

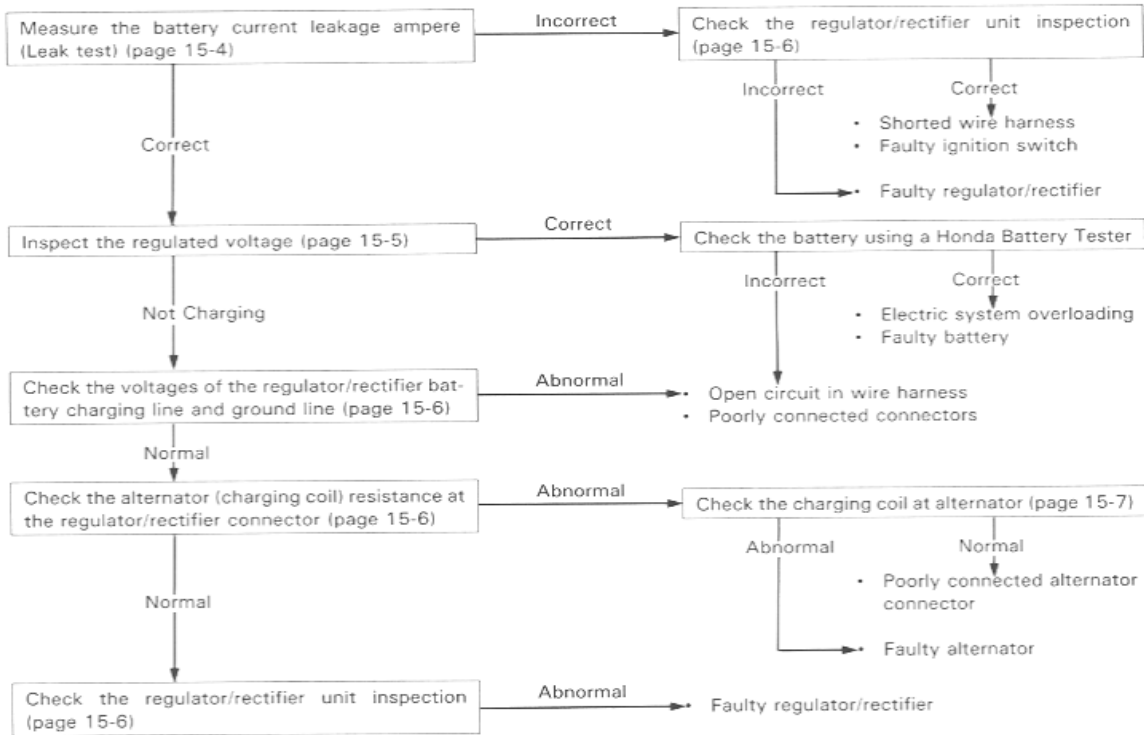

## Battery

### Removal

Open the trunk lid (Section 2).  
Remove the right lower cover (Section 2).

Turn off the ignition switch.  
Disconnect the negative (–) terminal cable first, then remove the battery holder and pull the battery out to remove the positive (+) terminal bolt.

Disconnect the positive (+) terminal cable at the battery.

### NOTE

- Be careful not to loose the terminal bolts and nuts.

### Installation

Install the battery in the reverse order of the removal.

After installing the battery, coat the terminals with clean grease.

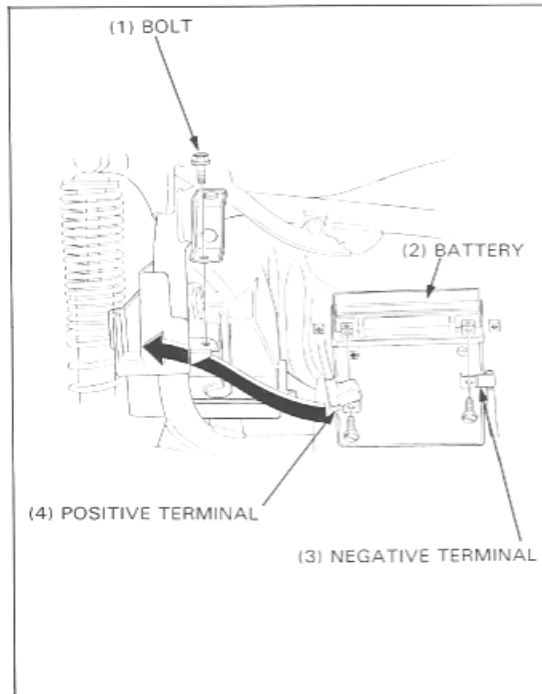

## Charging System Inspection

### Leak Test

Turn off the ignition switch, and disconnect the ground (–) cable from the battery.

Connect the ammeter (+) probe to the ground cable and the ammeter (–) probe to the battery (–) terminal.

With the ignition switch off, check for current leakage.

### NOTE

- When measuring current using a tester, set it to a high range, and then bring the range down to an appropriate level. Current flow larger than the range selected may blow out the fuse in the tester.
- While measuring current, do not turn the ignition on. A sudden surge of current may blow out the fuse in the tester.

**Specified Current Leakage:** 10  $\mu$ A max.

If current leakage exceeds the specified value, a shorted circuit is likely.  
Locate the short by disconnecting connections one by one and measuring the current.

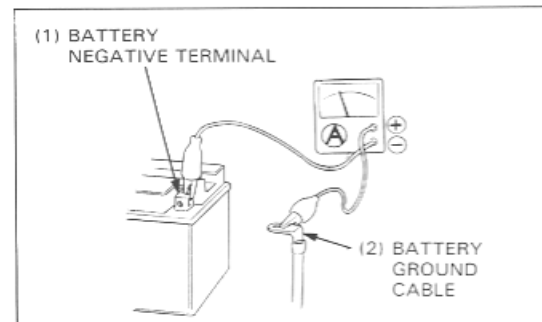

**Regulated Voltage/Ampere Inspection**

**NOTE**

- Before performing this test, be sure that the battery is fully charged and that the voltage between its terminals is greater than 12.8 V.

Open the trunk lid.  
Start the engine and warm it up to operating temperature, then turn the ignition switch OFF.

Connect a multimeter between the battery terminals.

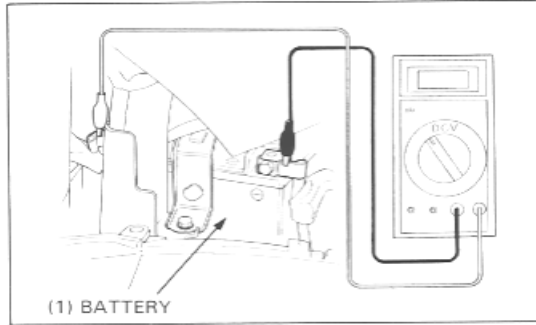

Multimeter Digital	07411-0020000 equivalent commercially available in U.S.A.
Analogue	07308-0020001 equivalent commercially available in U.S.A.

**WARNING**

- If the engine must be running to do some work, make sure the area is well-ventilated. Never run the engine in an enclosed area.
- The exhaust contains poisonous carbon monoxide gas that may cause loss of consciousness and lead to death.

Remove the front seat (Section 2).  
Disconnect the starter relay switch connector and remove the main fuse.  
Reconnect the connector securely.  
Connect the ammeter as shown.

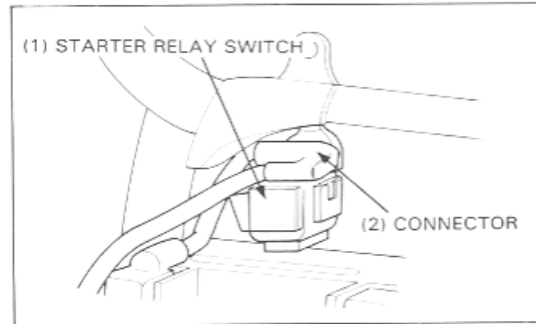

**CAUTION**

- Be careful not to short any tester probes.
- Although the current could be measured when the ammeter is connected between the battery positive terminal and the positive cable, a sudden surge of current to the starter motor could damage the ammeter.
- Always turn the ignition off when conducting the test. Disconnecting the ammeter or wires when current is flowing may damage the ammeter.

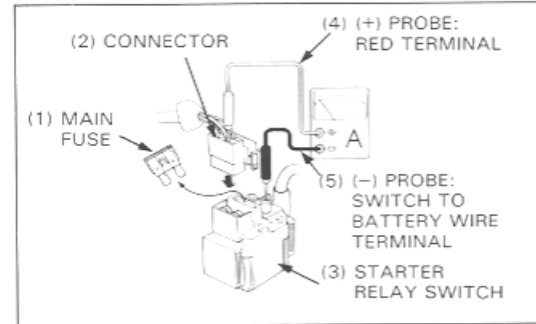

Start the engine and increase the engine speed gradually.

Regulated Voltage: 13.5 – 15.5 V/5,000 rpm  
Charging Current: 0 – 10 A/5,000 rpm

**Regulator/Rectifier**

**Wire Harness Inspection**

Remove the left air duct/maintenance lid (Section 2).  
Disconnect the 6P (WHITE) and 4P (WHITE) regulator/rectifier connectors.  
Check the connectors for loose or corroded terminals.

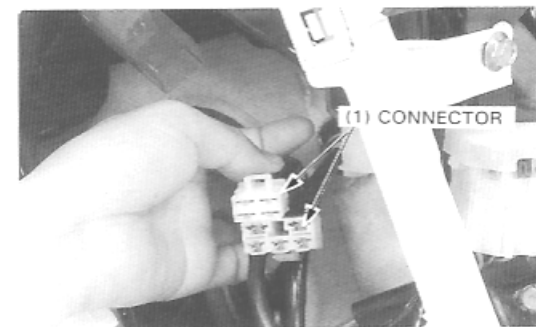

## Charging System/Alternator

Measure the following between connector terminals of the wire harness side.

Item	Terminals	Specification
Battery charging line	Red/White (+) and ground (-)	Battery voltage should register.
Ground line	Green and ground	Continuity exist.
Charging coil line	Yellow and Yellow	0.1 – 1.0 Ω (20°C/68°F)

If the charging coil line reading is out of specification, check the alternator (page 15-7).

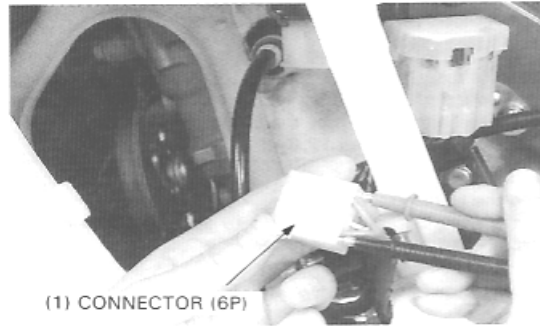

### Unit Inspection

Provided the circuit on the wire harness side are normal and there are no loose connections at the connector, inspect the regulator/rectifier unit by measuring the resistance between the terminals.

#### NOTE

- You'll get false readings if the probes touch your fingers.
- Use the specified multimeters. Using other equipment may not allow you to obtain the correct results. This is due to the characteristic of semiconductors, which have different resistance values depending on the applied voltage.

#### Specific Multimeter:

- 07411–0020000 (KOWA Digital type)
- KS–AHM–32–003 (KOWA Digital type; U.S.A. only)
- 07308–0020001 (SANWA Analogue type)
- TH–5H (KOWA Analogue type)

- Select the following range:  
SANWA: kΩ  
KOWA: X100
- An old battery stored in the multimeter could cause inaccurate readings. Check the battery if the multimeter resistance incorrectly.
- When using the KOWA multimeter, remember that all readings should be multiplied by 100.

Replace the regulator/rectifier unit if the resistance value between the terminals is abnormal.

Unit: kΩ

⊕ Probe	Red/White	Yellow 1	Yellow 2	Yellow 3	Green
⊖ Probe	Red/White	∞	∞	∞	∞
Yellow 1	0.5 – 10		30 – 500	30 – 500	10 – 200
Yellow 2	0.5 – 10	30 – 500		30 – 500	10 – 200
Yellow 3	0.5 – 10	30 – 500	30 – 500		0.5 – 200
Green	1 – 20	0.5 – 10	0.5 – 10	0.5 – 10	

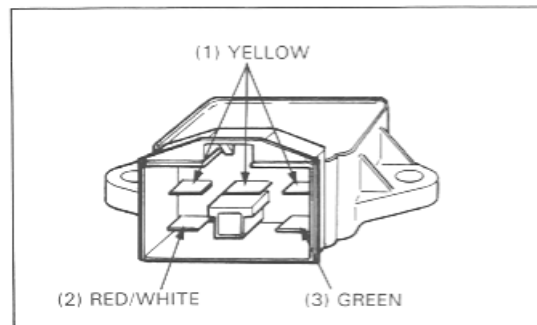

## Alternator

### Inspection

#### NOTE

- It is not necessary to remove the stator coil to make this test.

Remove the left air duct/maintenance lid (Section 2).

Disconnect the alternator 6P (WHITE) connector.

Measure the resistance between the yellow wire terminals and check for no continuity between each terminal and ground.

**Standard:** 0.1 – 1.0  $\Omega$  (20°C/68°F)

Replace the stator if the resistance is out of specification or if there is continuity between any yellow wire terminal and ground.

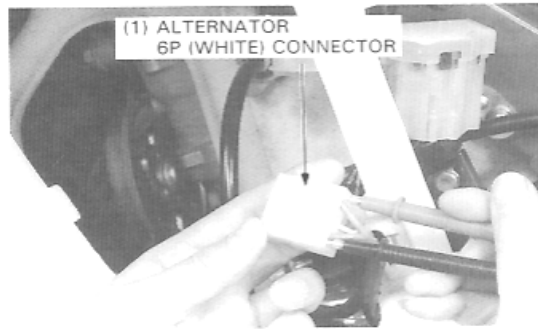

# Alternator Removal/Installation

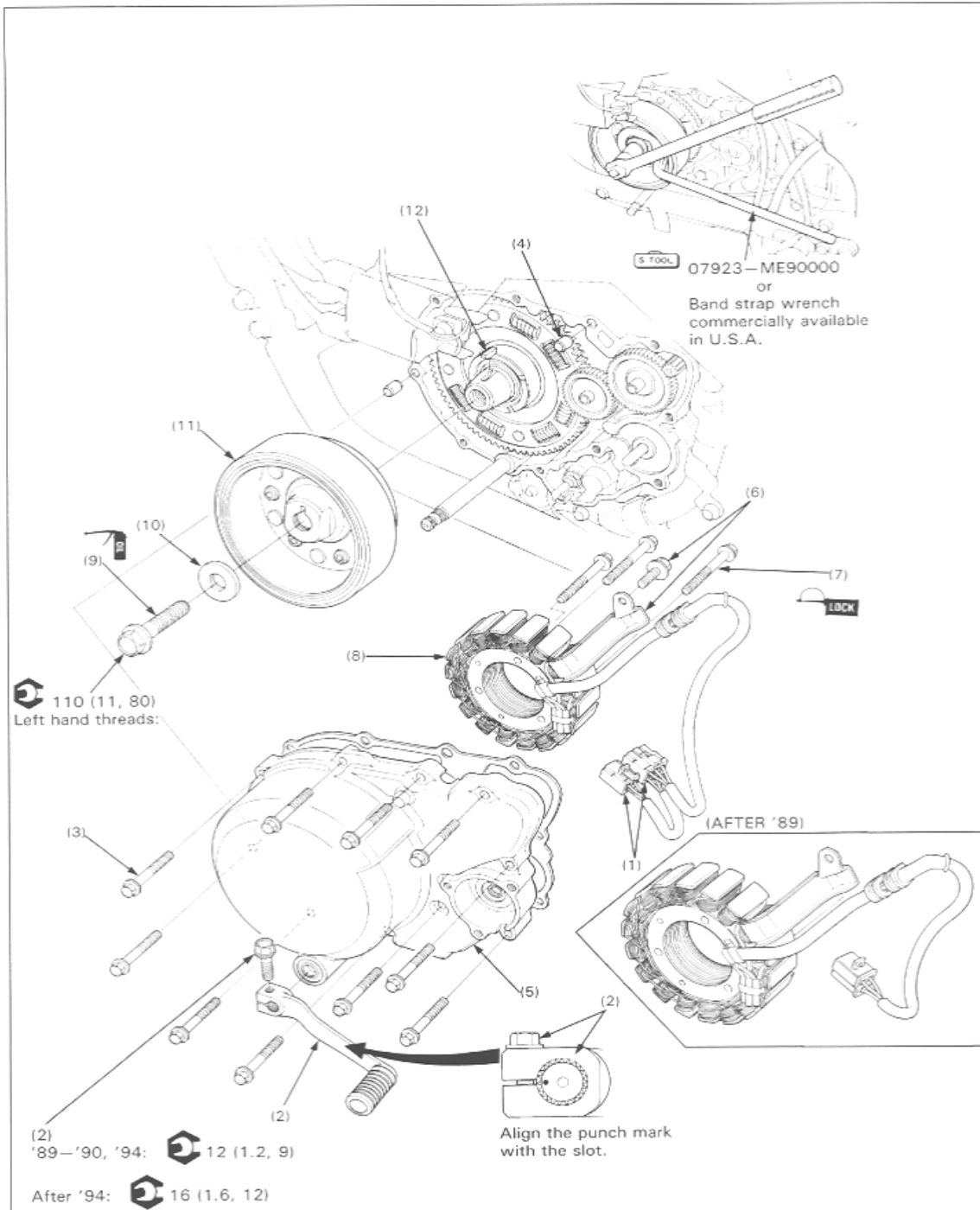

NOTE

- Engine oil will spill out when the left crankcase cover is removed. Set a clean oil pan under the engine and add the recommended oil to the specified level after installation.
- The left crankcase cover (stator) is magnetically attached to the flywheel; be careful when removing/installing.
- The flywheel bolt has left hand threads.

**Requisite Service**

- Clutch slave cylinder removal (page 9-4)

Procedure	Q'ty	Remarks
<b>Removal Order</b>		Installation is in the reverse order of removal.
(1) Alternator wire connector	1	Disconnect from the regulator/rectifier.
(2) Gear shift pedal/bolt	1	When installing, align the punch marks on the shaft with the pedal.
(3) Crankcase cover bolt	10	
(4) Dowel pin	2	
(5) Crankcase cover assembly	1	Remove the gasket from the engine.
(6) Wire clamp bolt/clamp	1	
(7) Stator mounting bolt	3	Apply a locking agent to the threads.
(8) Stator	1	
(9) Flywheel bolt	1	
(10) Washer	1	
(11) Flywheel	1	Use rotor puller (07933-3950000)
(12) Woodruff key	1	

---

# 16. Ignition System

Service Information	16-1	Ignition Pulse Generator	16-6
System Location	16-2	Ignition Timing	16-7
Troubleshooting	16-3	Ignition Pulse Generator Removal/Installation	16-8
Ignition System Inspection	16-5		
Ignition Coil	16-6		

## Service Information

- When checking the ignition system, always follow the steps in the troubleshooting flow chart (page 16-3).
- The digital transistorized ignition system uses an electrically controlled ignition timing system. No adjustments can be made to the ignition timing.
- A rough diagnosis can be made by identifying the cylinder whose spark timing is incorrect.
- The ignition control module (ICM) may be damaged if dropped. Also, if the connector is disconnected when current is flowing, the excessive voltage may damage the unit. Always turn off the ignition switch before servicing.
- A faulty ignition system is often related to poorly connected connectors. Check those connections before proceeding.
- Make sure the battery is adequately charged. Using the starter motor with a weak battery results in a slower engine cranking speed and no spark at the spark plugs.
- Use spark plugs of the correct heat range. Using spark plugs with an incorrect heat range can damage the engine. Refer to section 2 of the Common Service Manual.
- For neutral switch inspection, refer to section 25 of the Common Service Manual; for switch location, see page 16-2 of this manual (System Location).
- For the ignition switch, engine stop switch and side stand switch inspection, check for continuity on the continuity chart of the Wiring Diagram, page 19-1. Disconnect the ignition and engine stop switch connectors (behind the instruments) (page 1-22), and the side stand switch connector (beside the left shock absorber) and check them.

## System Location

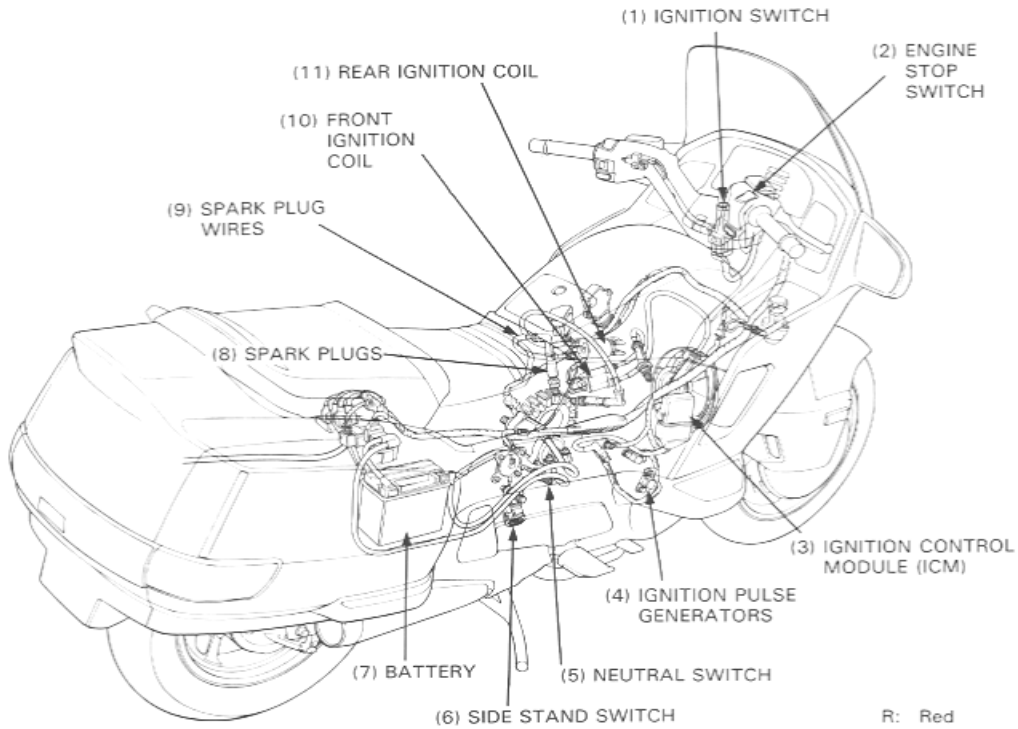

R: Red  
 Bl: Black  
 W: White  
 Y: Yellow  
 Bu: Blue  
 G: Green

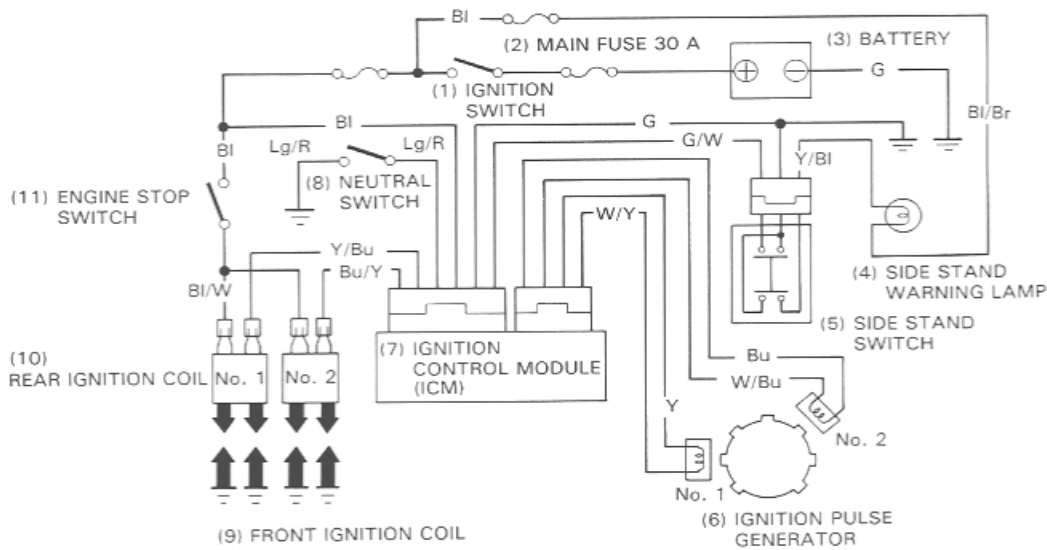

## Troubleshooting

**⚠ WARNING**

- When performing a spark test, keep open flames or sparks away from the work area.

**No Spark at One Spark Plug**

- Faulty spark plug
- Faulty spark plug wire

**No Spark at All Plugs**

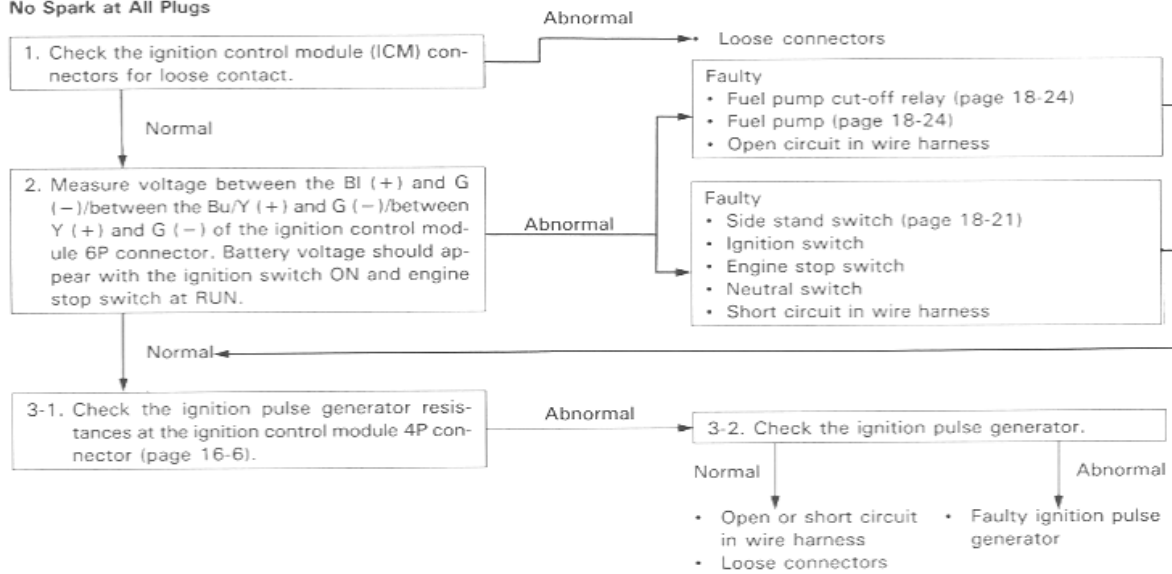

**No Spark at One Spark Group (Front or Rear) – (Check Wrong Spark Group)**

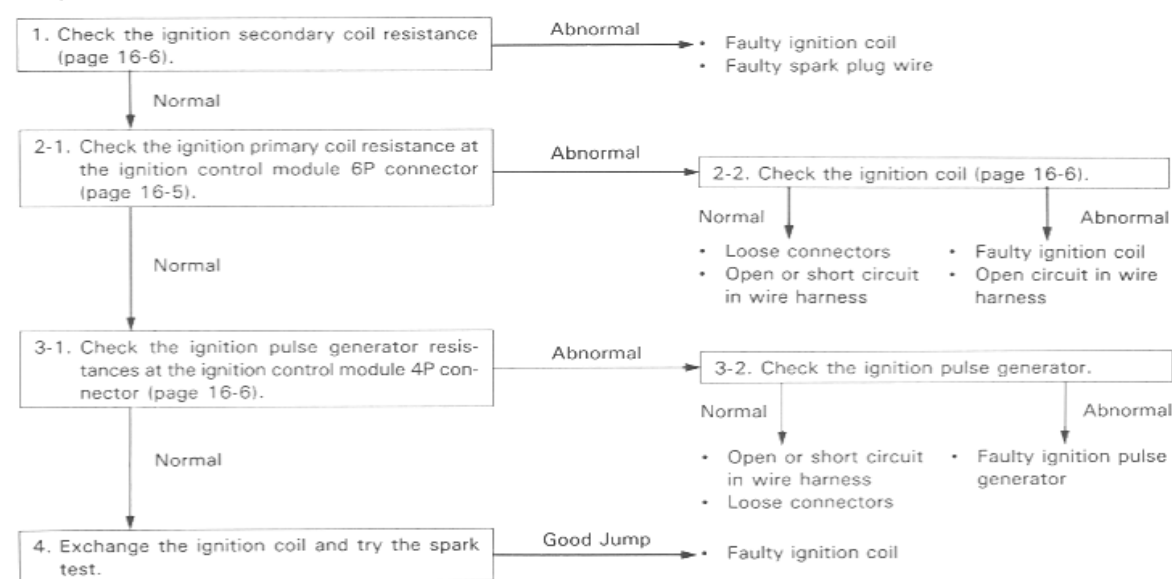

## Ignition System

---

Side stand switch does not function at all.

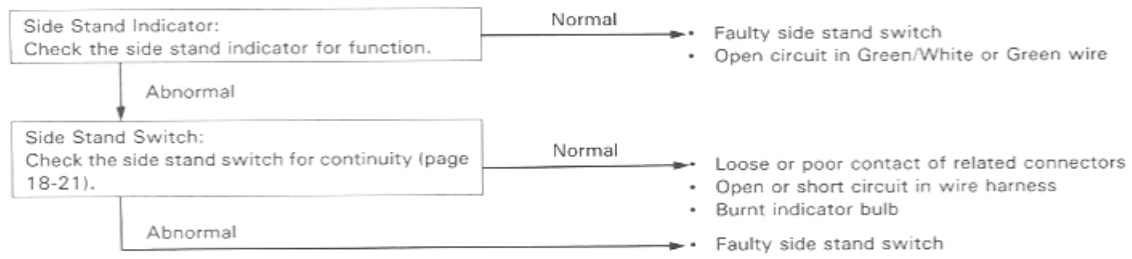

## Ignition System Inspection

Remove the right air duct/maintenance lid (Section 2).

Remove the waterproof cover from the ignition control module (ICM).

**NOTE**

- Check the system components and lines step-by-step according to the troubleshooting chart on pages 16-2, 3, 4.

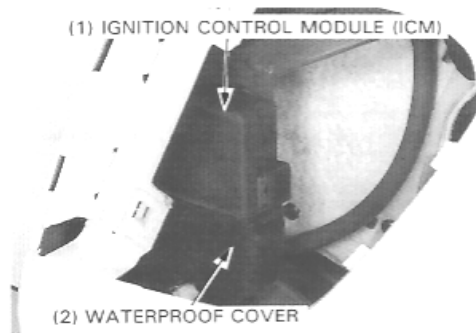

Disconnect the ignition control module (ICM) connectors and check them for loose or corroded terminals.

Measure the data between connector terminals using the following chart.

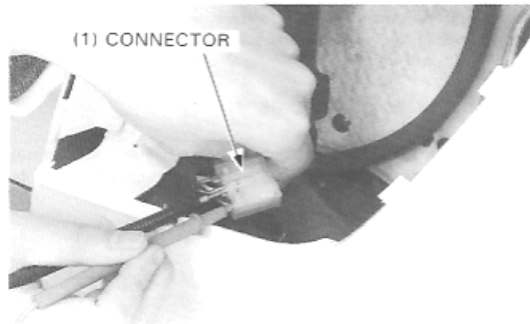

<6P Connector>

Item		Terminals	Standards (20°C/68°F)
Ignition primary coil	Front	Bu/Y and BI/W	2.0–3.0 Ω
	Rear	Y/Bu and BI/W	
Battery voltage input line		BI (+) and G (-), Bu/Y (+) and G (-), Y/Bu (+) and G (-), Ignition switch "ON" and engine stop switch "RUN"	Battery voltage should come
Side stand switch line	Stand retracted	G/W (+) and G (-)	Continuity
		Y/BI (+) and G (-)	No continuity
	Stand down	G/W (+) and G (-)	No continuity
		Y/BI (+) and G (-)	Continuity
Neutral switch line	In neutral	Lg/R (+) and G (-)	Continuity
	In any gear	Lg/R (+) and G (-)	No continuity

<4P Connector>

Item	Terminals	Standards (20°C/68°F)
Ignition pulse generator	W/Bu and Bu (Front) W/Y and Y (Rear)	400–500 Ω
	Each terminal and body ground	No continuity

## Ignition Coil

### Inspection

Remove the left side cover (Section 2). Measure the primary coil resistance of the front and rear ignition coils.

**Primary Coil Resistance:**  
Standard: 2.0–3.0  $\Omega$  (20°C/68°F)



Disconnect the spark plug caps from the plugs and measure the secondary coil resistance with the spark plug caps in place.

Standard: 28–38 k $\Omega$  (20°C/68°F)

If the resistance is out of range, remove the spark plug caps and measure the resistance between the secondary coil terminals.

Standard: 20–25 k $\Omega$  (20°C/68°F)

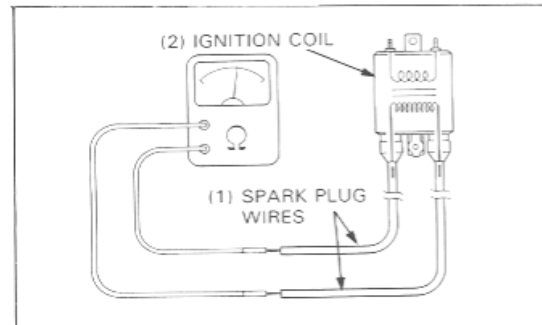
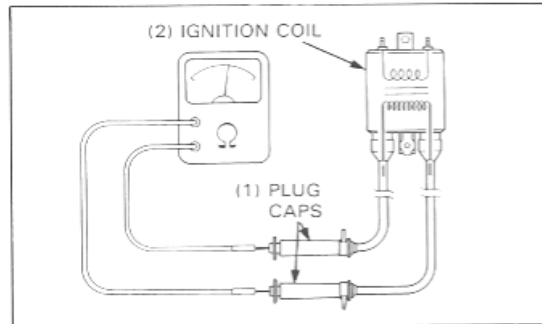

## Ignition Pulse Generator

### Inspection

#### NOTE

- It is not necessary to remove the ignition pulse generator to make this inspection.

Remove the right air duct/maintenance lid (Section 2).

Disconnect the ignition pulse generator 4P-White connector from the ignition control module.

Measure the resistance between the White/Blue and Blue wires (Front ignition pulse generator) and White/Yellow and Yellow wires (Rear ignition pulse generator).

Standard: 400–500  $\Omega$  (20°C/68°F)

For ignition pulse generator replacement (page 16-8).

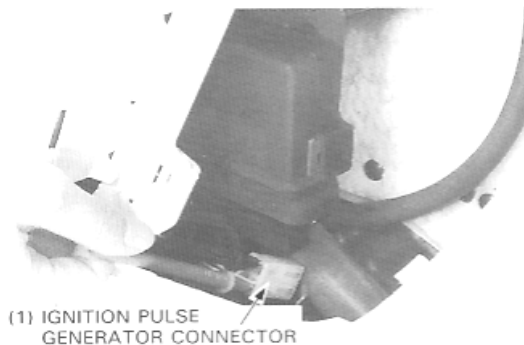

## Ignition timing

### NOTE

- The ignition control module system is factory pre-set and cannot be adjusted. Ignition timing inspection procedures are given to inspect the function of the ignition control module components.
- Connect the timing light to the other spark plug wire if you see that the ignition timing is incorrect, and you might be able to see the timing is correct.

Warm up the engine to operating temperature.

### ▲WARNING

- If the engine must be running to do some work, make sure the area is well-ventilated. Never run the engine in an enclosed area.
- The exhaust contains poisonous carbon monoxide gas that may cause loss of consciousness and lead to death.

Remove the front lower cowl and right lower cover (Section 2).

Remove the timing inspection hole cap on the right crankcase cover.

Connect the timing light to the front spark plug wire.

The timing is correct if the "F" mark aligns with the index mark on the right crankcase cover at idle for each cylinder.

### Idle Speed: 1,200 ± 100 rpm

Check that the "F" mark begins to move when the engine speed reaches the advance start rpm.

At 4,500 rpm, the ignition timing is correct if the index mark is between the two advance marks.

If the ignition timing is incorrect, inspect the ignition system (page 16-5) and replace any faulty parts.

Check the timing hole cap's O-ring for damage, replace the new one if desired.

Apply molybdenum disulfide oil to the threads, and install the timing inspection hole cap.

Torque: 10 N·m (1.0 kg·m, 7.2 ft·lb)

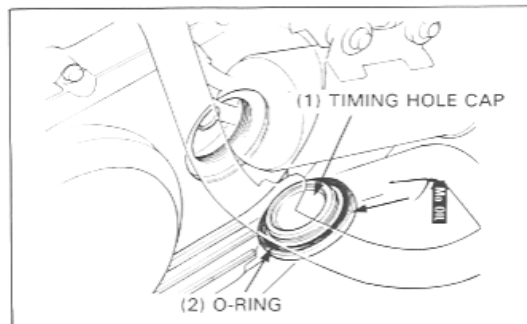
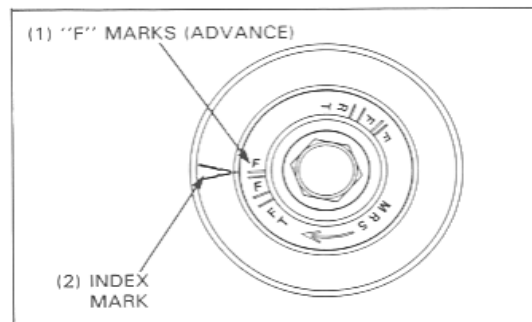
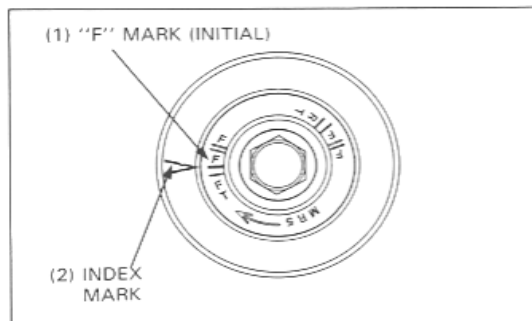
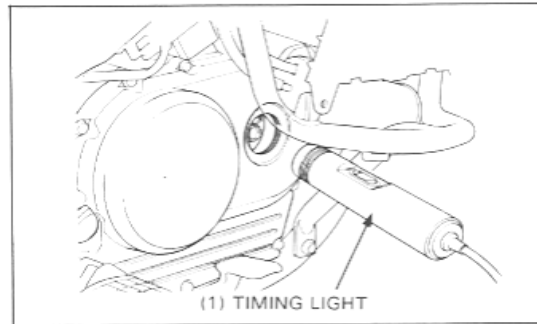

## Ignition Pulse Generator Removal/Installation

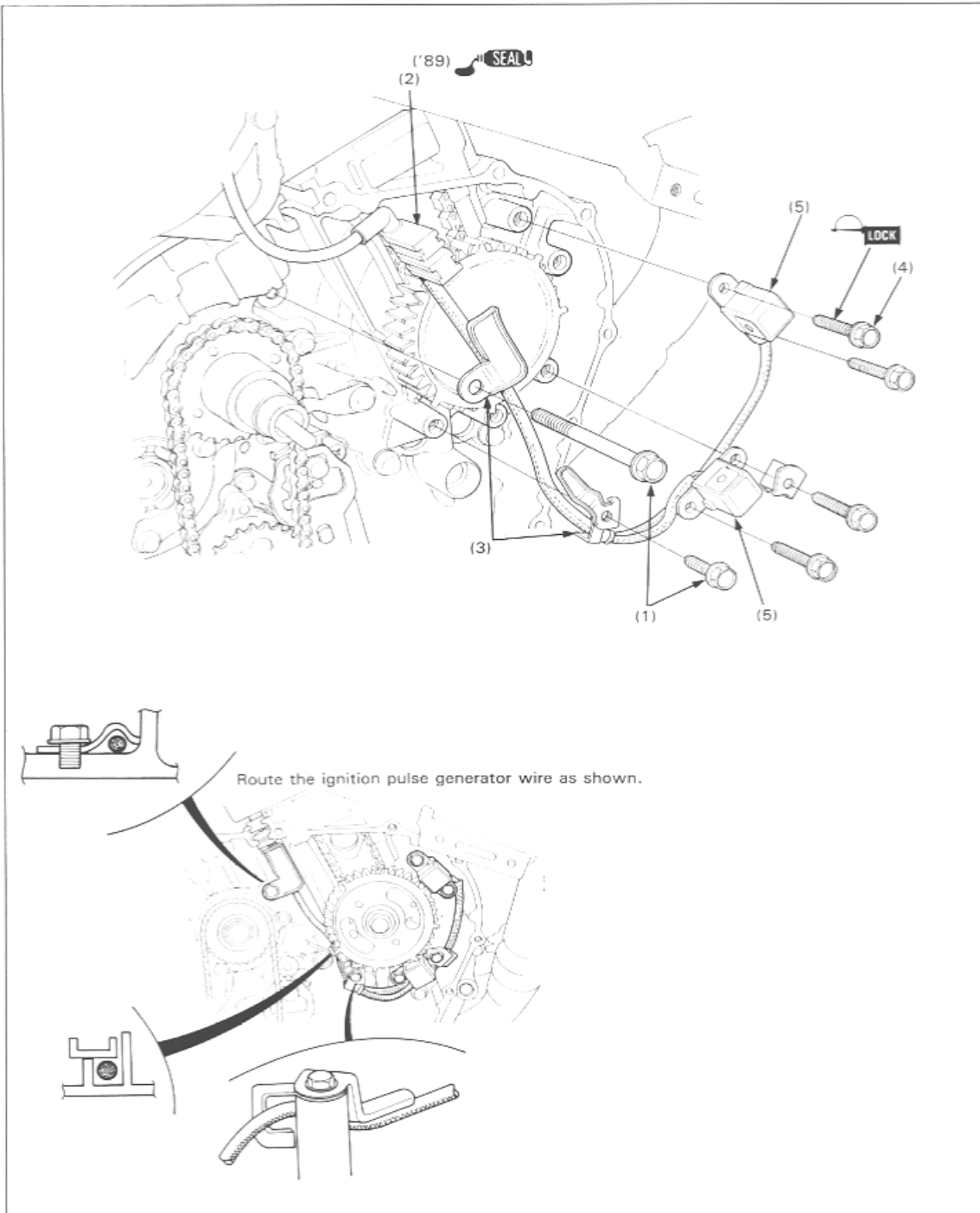

**Requisite Service**

- Right crankcase cover removal/installation (page 9-5)
- Clutch removal/installation (page 9-6)

Procedure		Q'ty	Remarks
<b>Removal Order</b>			
(1)	Wire clamp bolt	2	Disconnect the ignition pulse generator connector from the ignition control module. Remove the grommet from the crankcase.
(2)	Wire grommet	1	
(3)	Wire clamp	2	
(4)	Ignition pulse generator mounting bolt	4	
(5)	Ignition pulse generator	2	
<b>Installation Order</b>			
(5)	Ignition pulse generator	2	Route the wire as shown. Make sure the dowel pins are in place and the wire clamps are attached.
(4)	Ignition pulse generator mounting bolt	4	
(3)	Wire clamp	2	Install the grommet onto the crankcase groove securely.
(1)	Wire clamp bolt	2	
(2)	Wire grommet	1	

# 17. Electric Starter/Starter Clutch

Service Information	17-1	Starter Motor Disassembly/Assembly	17-6
Troubleshooting	17-1	Starter Relay Switch	17-7
System Location	17-3	Starter Clutch Removal/Installation	17-8
Starter Motor Removal/Installation	17-4		

## Service Information

### ▲ WARNING

- Always turn the ignition switch OFF before servicing the starter motor. The motor could suddenly start, causing serious injury.
- A weak battery may be unable to turn the starter motor quickly enough, or supply adequate ignition current.
- If the current is kept flowing through the starter motor to turn it while the engine is not cranking over, the starter motor may be damaged.
- For the following component inspections, refer to the following pages; for the parts locations, see page 17-3 of this manual (System Location).

Clutch switch diode	Section 24 of the Common Service Manual.
Starter motor	Section 24 of the Common Service Manual.
Clutch switch	Section 25 of the Common Service Manual.
Neutral switch	Section 25 of the Common Service Manual.
Ignition switch	Check for continuity on the continuity chart of the Wiring Diagram, page 19-1. Disconnect the switch connector behind the instruments (page 1-22) and check it.
Side stand switch	(page 18-21)

## Troubleshooting

### NOTE

- Check for the following before troubleshooting the system.
  - Blown main (30 A) or sub (10 A) fuse.
  - Loose battery and starter motor cables.
  - Discharged battery.
- The starter motor should turn when the transmission is in neutral.
- The starter motor should turn when the transmission is in any gear with relative circuit satisfied, indicated below chart.

17

	Side Stand	Clutch Lever	Starter Motor
Gear Position: Any Gear	Up	Pulled in	Turn
		Free	Does Not Turn
	Down	Pulled in	Does Not Turn
		Free	Does Not Turn

### Starter Motor Does Not Turn

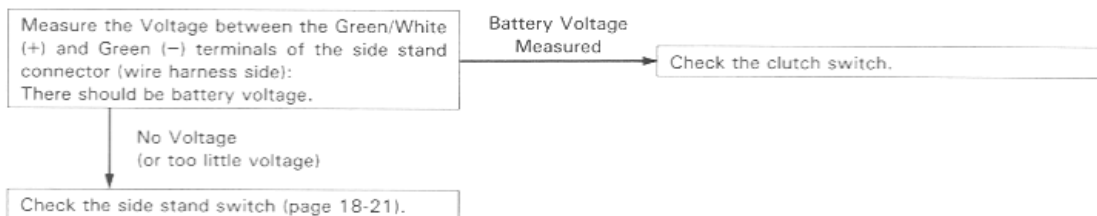

17-1

## Electric Starter/Starter Clutch

### Starter Motor Does Not Turn With the Side Stand Switch is Normal

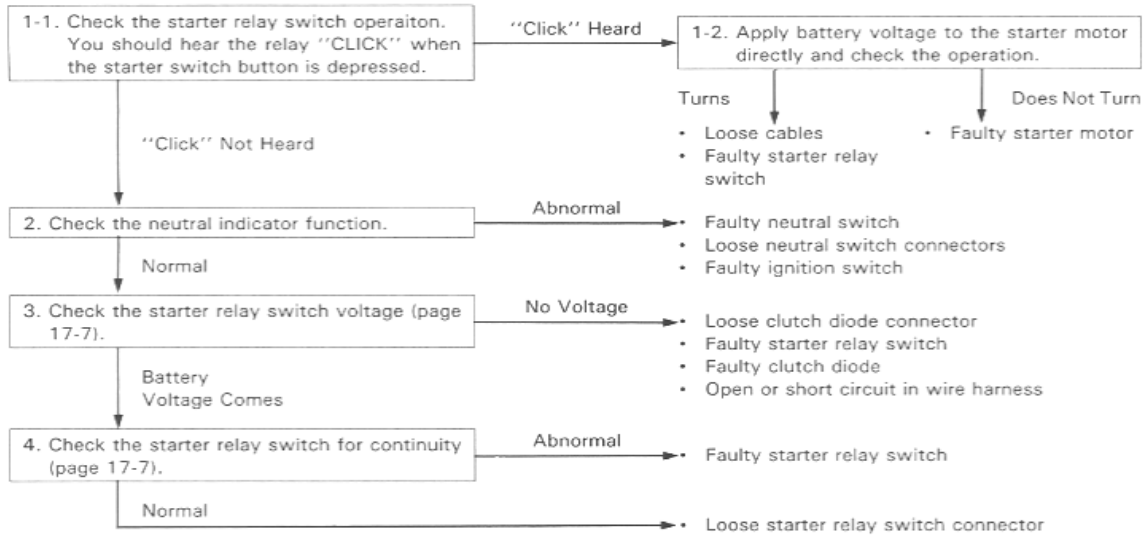

### Starter Motor Turns Engine Slowly

- Weak battery
- Excessive resistance in circuit
- Binding in starter motor

### Starter Motor Turns, But Engine Does Not Turn

- Faulty starter clutch
- Faulty starter motor gears

### Starter Motor and Engine Turns, But Engine Does Not Start

- Faulty ignition system
- Engine problems
  - Low compression
  - Fouled spark plugs

System Location

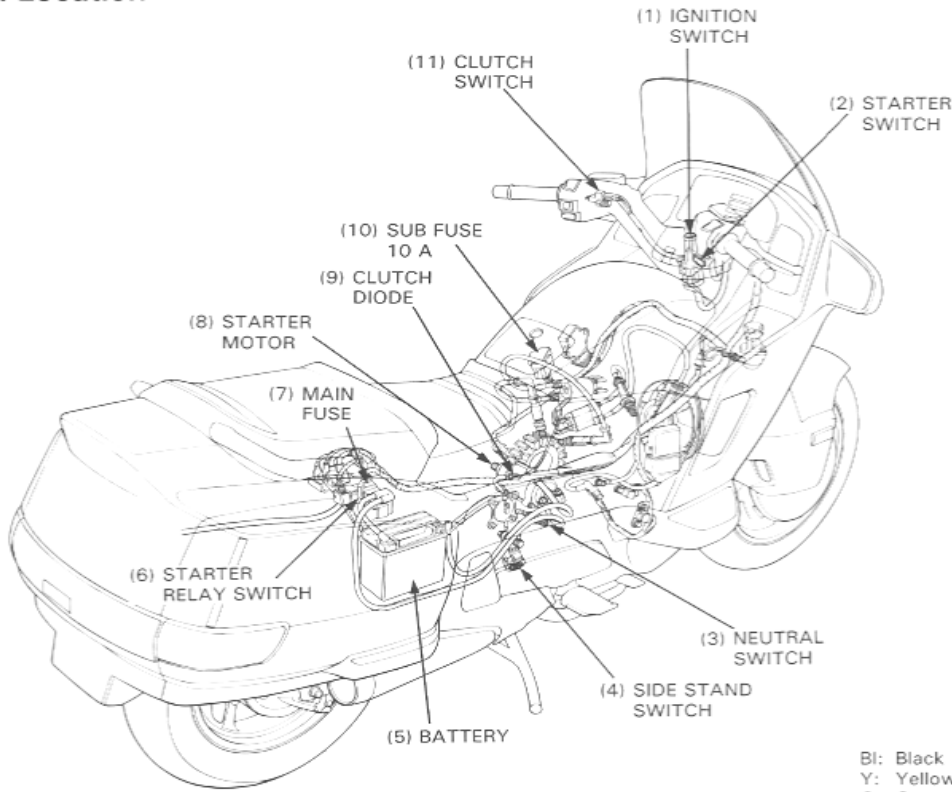

Bl: Black  
 Y: Yellow  
 G: Green  
 R: Red  
 W: White  
 Lg: Light green

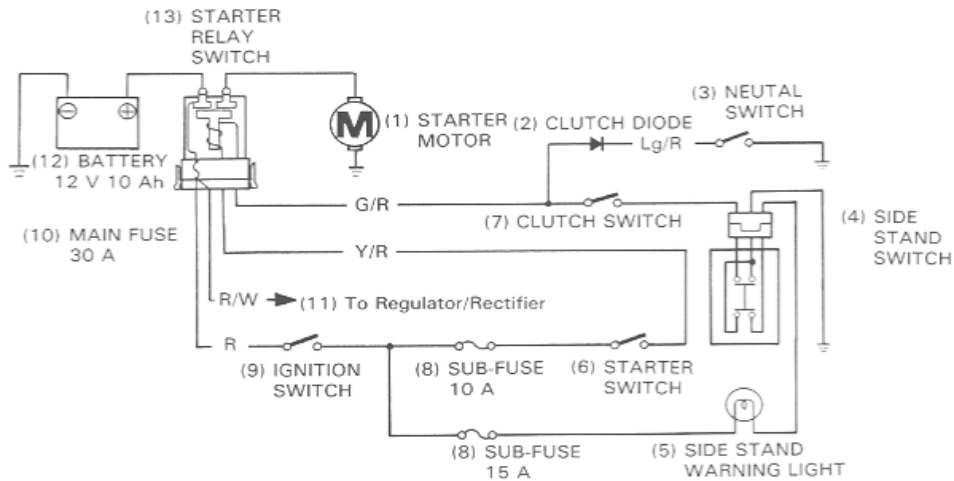

### Starter Motor Removal/Installation

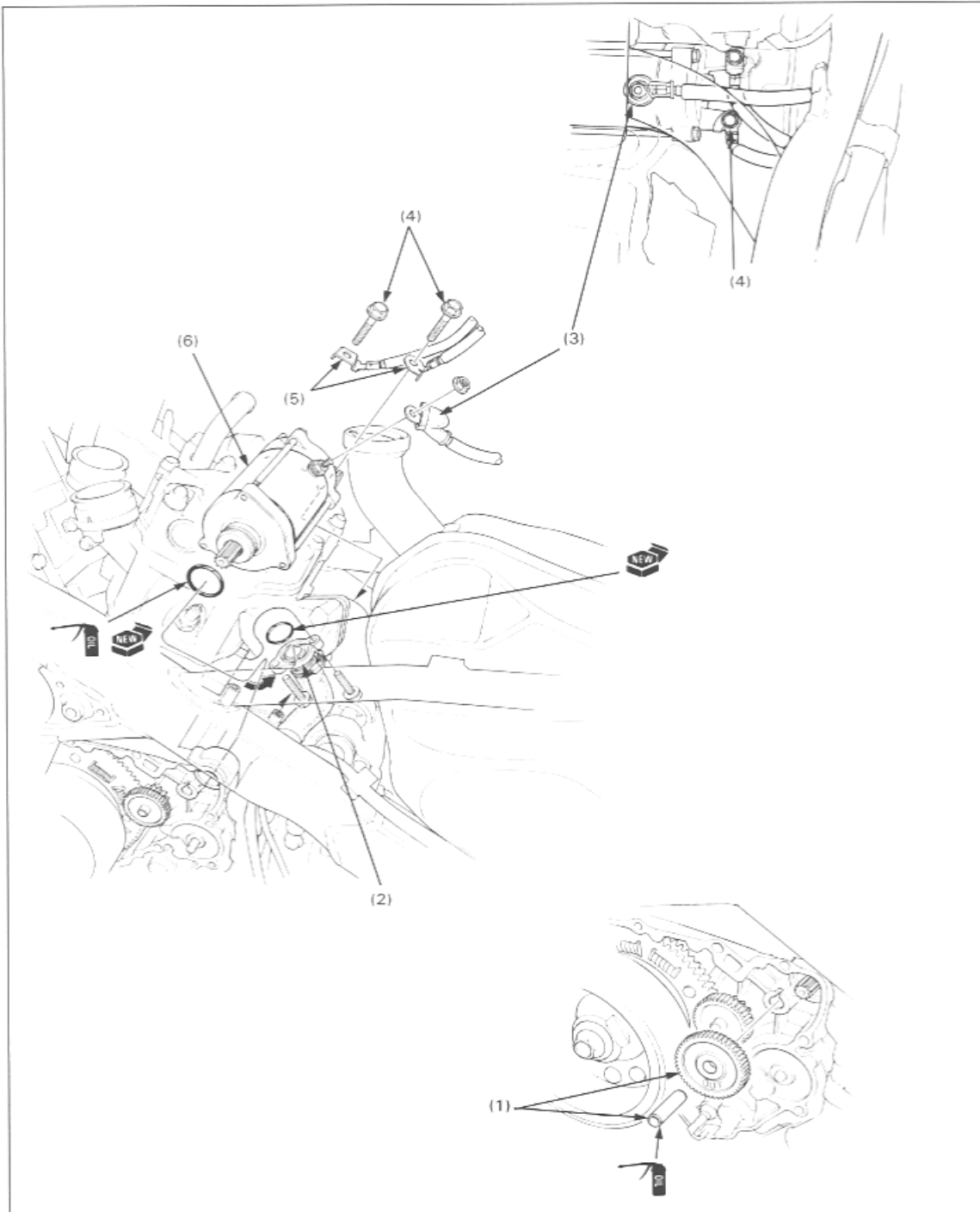

**▲ WARNING**

- With the ignition switch OFF, remove the negative cable at the battery before servicing the starter motor.

**Requisite Service**

- Radiator coolant draining (page 6-2)
- Engine heat cover removal/installation (page 7-2)
- Left crankcase cover removal/installation (page 15-8)

Procedure		Q'ty	Remarks
<b>Removal Order</b>			
(1)	Starter drive gear shaft/gear	1	Remove the rubber cap and remove the nut.
(2)	Rear cylinder water hose connector	1	
(3)	Starter motor cable	1	
(4)	Starter motor mounting bolt	2	
(5)	Ground cable terminal	2	
(6)	Starter motor	1	
<b>Installation Order</b>			
(6)	Starter motor	1	Apply engine oil to the O-ring.
(5)	Ground cable terminal	2	Route the ground cable correctly (page 1-22).
(4)	Starter motor mounting bolt	2	Connect the cable, tighten the nut and install the rubber cap.
(3)	Starter motor cable	1	
(2)	Rear cylinder water hose connector	1	Apply engine oil to the new O-ring and install the connector onto the rear cylinder.
(1)	Starter drive gear shaft/gear	1	Install the starter drive gear with the "OUTSIDE" mark on the gear facing out.

## Starter Motor Disassembly/Assembly

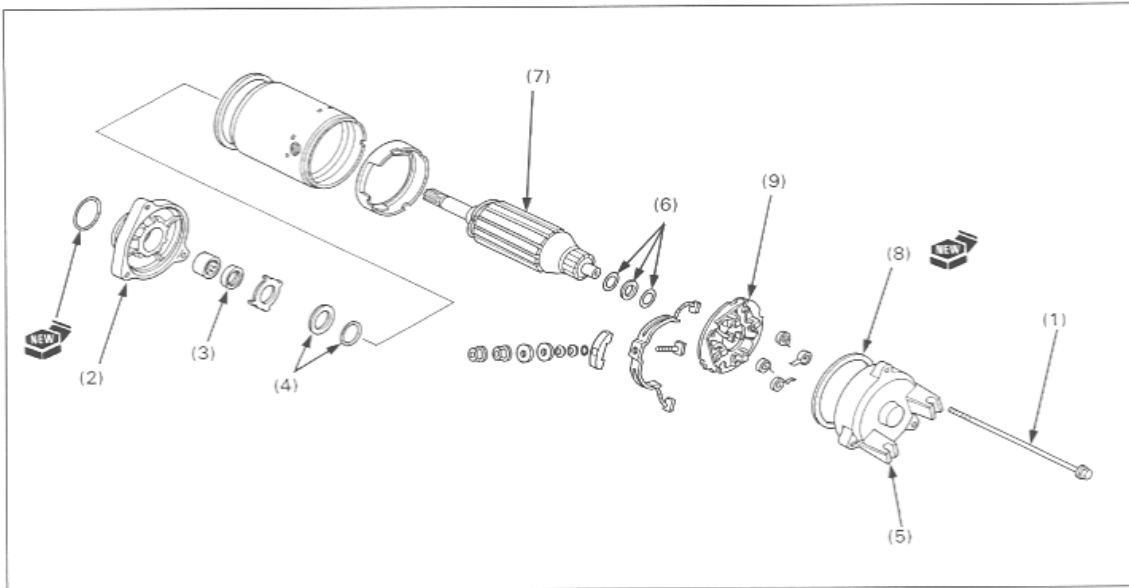

**NOTE**

- Note the location and number of thrust washers when disassembling.

**Requisite Service**

- Starter motor removal (page 17-4)

Procedure	Q'ty	Remarks
<b>Disassembly Order</b>		
(1) Case mounting screw	3	Assembly is in the reverse order of disassembly.
(2) Front cover	2	
(3) Dust seal	1	Note the location and number of thrust washers.
(4) Thrust washer	—	
(5) Rear cover	1	
(6) Thrust washer	—	Note the location and number of thrust washers.
(7) Armature	1	
(8) O-ring	1	
(9) Brush holder assembly	1	

## Starter Relay Switch

### Operation Inspection

Depress the starter switch button with the ignition switch ON.

The coil is normal if the starter relay switch clicks.

### Voltage Inspection

If you don't hear the switch "CLICK", disconnect the switch connector.

Shift the transmission into neutral and turn the ignition switch ON.

Measure the voltage between the Yellow/Red (+) and Green/Red (-) wires of the relay connector as you press the starter. The tester should show battery voltage. If it does not, make the following continuity inspection.

### Continuity Inspection

Remove the starter relay switch.  
Connect an ohmmeter to the switch large terminals.

Connect a fully charged 12 V battery positive wire to the starter relay switch Yellow/Red wire terminal, and the battery negative wire to the Green/Red wire terminal.

There should be continuity while the battery is connected to the terminals, and no continuity when the battery is disconnected.

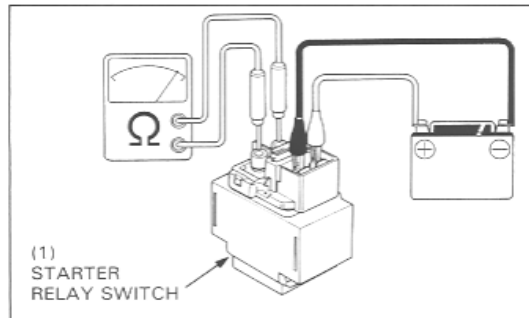
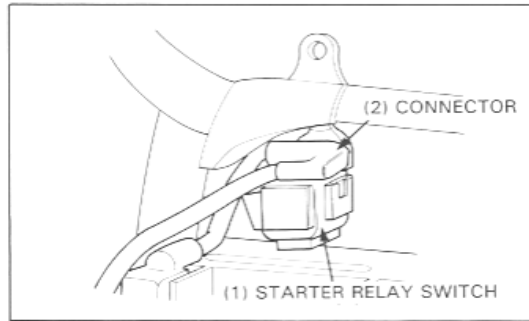

### Starter Clutch Removal/Installation

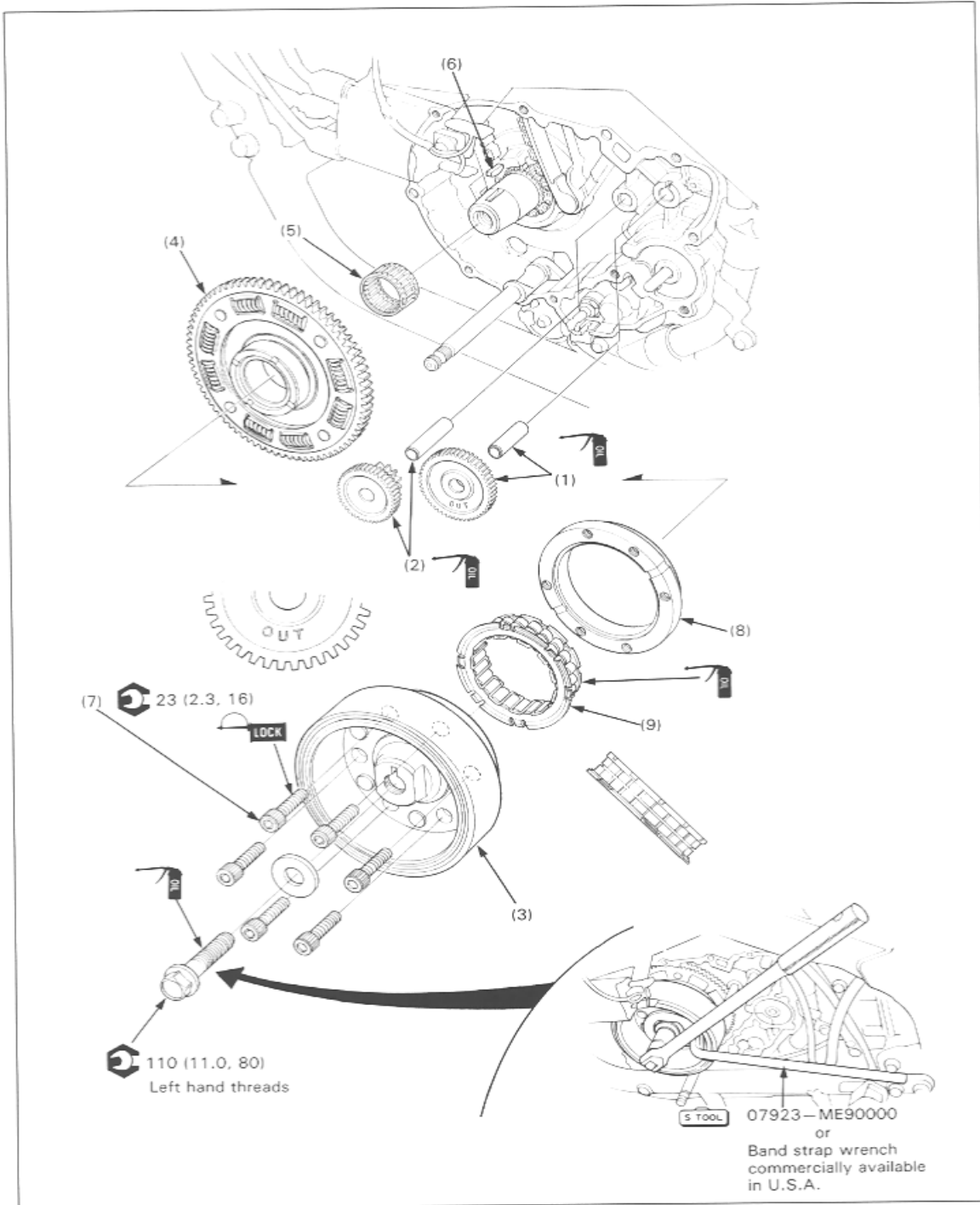

NOTE

- The engine oil will spill out when the left crankcase cover is removed. Set a clean oil pan under the engine and add the recommended oil to the specified level after installation.

Requisite Service

- Clutch slave cylinder removal (page 9-4)
- Alternator removal (page 15-8)

Procedure		Q'ty	Remarks
<b>Removal Order</b>			
(1)	Starter drive gear shaft/gear	1	Use rotor puller (07933-3950000). Hold the needle bearing, and do not pull out the gearshift spindle.
(2)	Reduction gear shaft/gear	1	
(3)	Flywheel assembly	1	
(4)	Starter driven gear	1	
(5)	Needle bearing	1	
(6)	Woodruf key	1	
(7)	Starter clutch bolt	6	Locking agent to the threads.
(8)	Starter clutch outer	1	
(9)	Starter oneway clutch	1	
<b>Installation Order</b>			
(9)	Starter oneway clutch	1	The flange side facing to the flywheel.
(8)	Starter clutch outer	1	
(7)	Starter clutch bolt	6	Apply a locking agent to the threads.
(6)	Woodruf key	1	Insert the bearing, while holding the starter driven gear.
(4)	Starter driven gear	1	
(5)	Needle bearing	1	
(3)	Flywheel assembly	1	
(2)	Reduction gear shaft/gear	1	
(1)	Starter drive gear shaft/gear	1	

## Electric Starter/Starter Clutch

### Starter Oneway Clutch Installation

Apply clean engine oil to the oneway clutch roller surfaces.

#### CAUTION

- Do not apply molybdenume disulfide additive oil to the oneway clutch sliding surfaces.

Install the oneway clutch into the clutch outer, with the flange side facing to the flywheel.

Install the starter clutch assembly onto the flywheel.

Clean and apply a locking agent to the threads.  
Tighten the mounting bolts to the specified torque.

Torque: 23 N·m (2.3 kg·m, 16 ft·lb)

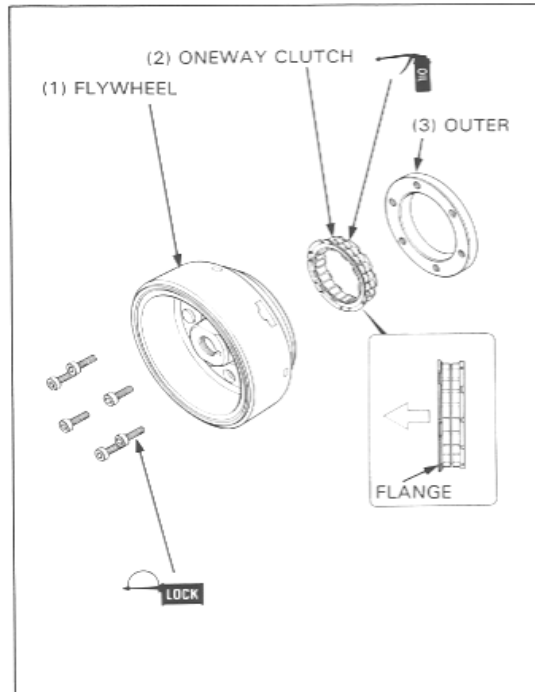





# 18. Lights/Meters/Switches

Service Information	18-1	Self-cancelling Turn Signal System ('89 - '90, '94 - '96)	18-17
System Location	18-2	Ignition Switch Removal/Installation	18-19
Self-cancelling Turn Signal System Diagram ('89 - '90, '94 - '96)	18-3	Side Stand Switch Removal/Installation	18-20
Troubleshooting ('89 - '90, '94 - '96)	18-4	Side Stand Switch Inspection	18-21
Headlight	18-8	Fuel Pump and Fuel Filter Removal/Installation	18-22
Front Turn Signal	18-8	Fuel Cut-off Relay	18-24
Rear Turn Signal	18-9	Fuel Pump	18-24
Brake and Taillight	18-10	Fuel Level Sensor Removal/Installation	18-25
License Light	18-11	Fan Motor Switch	18-26
Combination Meter Removal/Installation	18-12	Thermo Sensor	18-26
Combination Meter Disassembly/Assembly	18-14	Temperature Gauge	18-27
Instruments	18-16		

## Service Information

### ▲ WARNING

- A halogen headlight bulb becomes very hot while the headlight is ON, and remain hot for a while after it is turned OFF. Be sure to let it cool down before servicing.
- Use a flame and heated water/coolant mixture for the thermo sensor inspection. Keep all flammable materials away from the burner. Wear protective clothing, gloves and eye protection.

- Note the following when replacing the halogen headlight bulb.
    - Wear clean gloves while replacing the bulb. Do not put finger prints on the headlight bulb, as they may create hot spots on the bulb and cause it to break.
    - If you touch the bulb with your bare hands, clean it with a cloth moistened with alcohol to prevent its early failure.
    - Be sure to install the dust cover after replacing the bulb.
  - Check the battery condition before performing any inspection that requires proper battery voltage.
  - A continuity test can be made with the switches installed on the motorcycle.
- For the following component locations, see page 18-2 of this manual (System Location); for inspections, refer to the applicable pages.

18

Component	Inspection method	Remarks
Clutch switch	Section 25 of the Common Service Manual	
Front brake light switch	Section 25 of the Common Service Manual	
Horn	Section 25 of the Common Service Manual	
Handlebar switches	Check for continuity on the continuity chart of the Wiring Diagram, page 19-1.	Switch connectors are located behind the instruments (page 1-22).
Ignition switch		
Neutral switch	Section 25 of the Common Service Manual	TORQUE: 12 N-m (1.2 kg-m, 9 ft-lb) Apply sealant to the threads.
Oil pressure switch/warning light	Section 25 of the Common Service Manual	Oil pressure check: Section 4 of the Common Service Manual Oil pressure switch torque: 12 N-m (1.2 kg-m, 9 ft-lb)
Rear brake light switch	Section 25 of the Common Service Manual	
Turn signal lights	Section 25 of the Common Service Manual	3 terminals relay.

18-1

## System Location

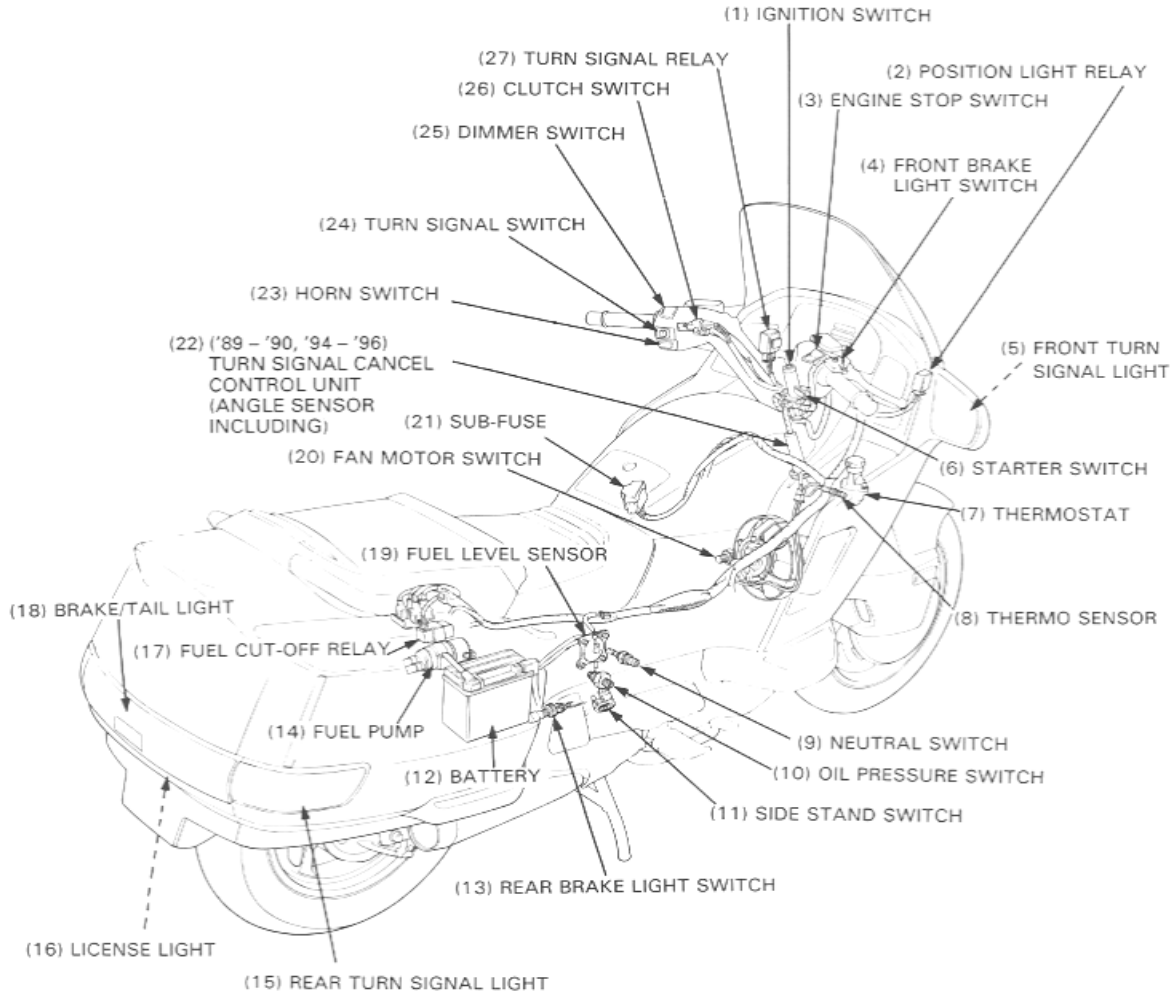

## Self-cancelling Turn Signal System Diagram ('89 - '90, '94 - '96)

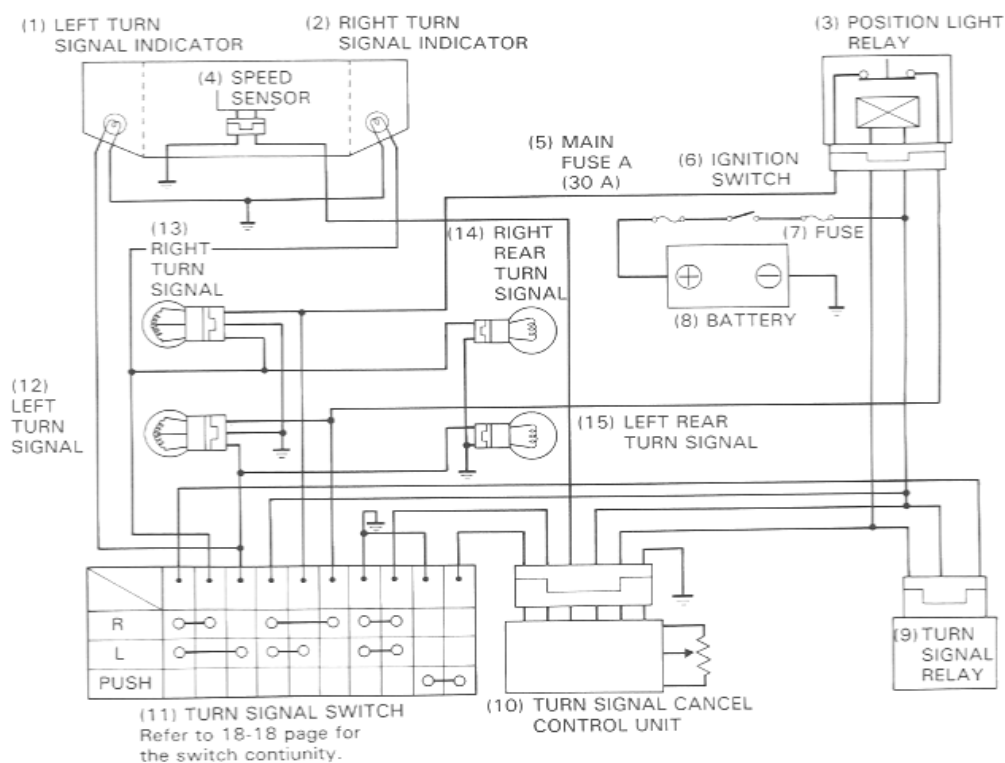

## Troubleshooting ('89 - '90, '94 - '96)

Turn signals do not operate.

NOTE

- If one bulb is burnt out, turn signals should blink faster than normal.

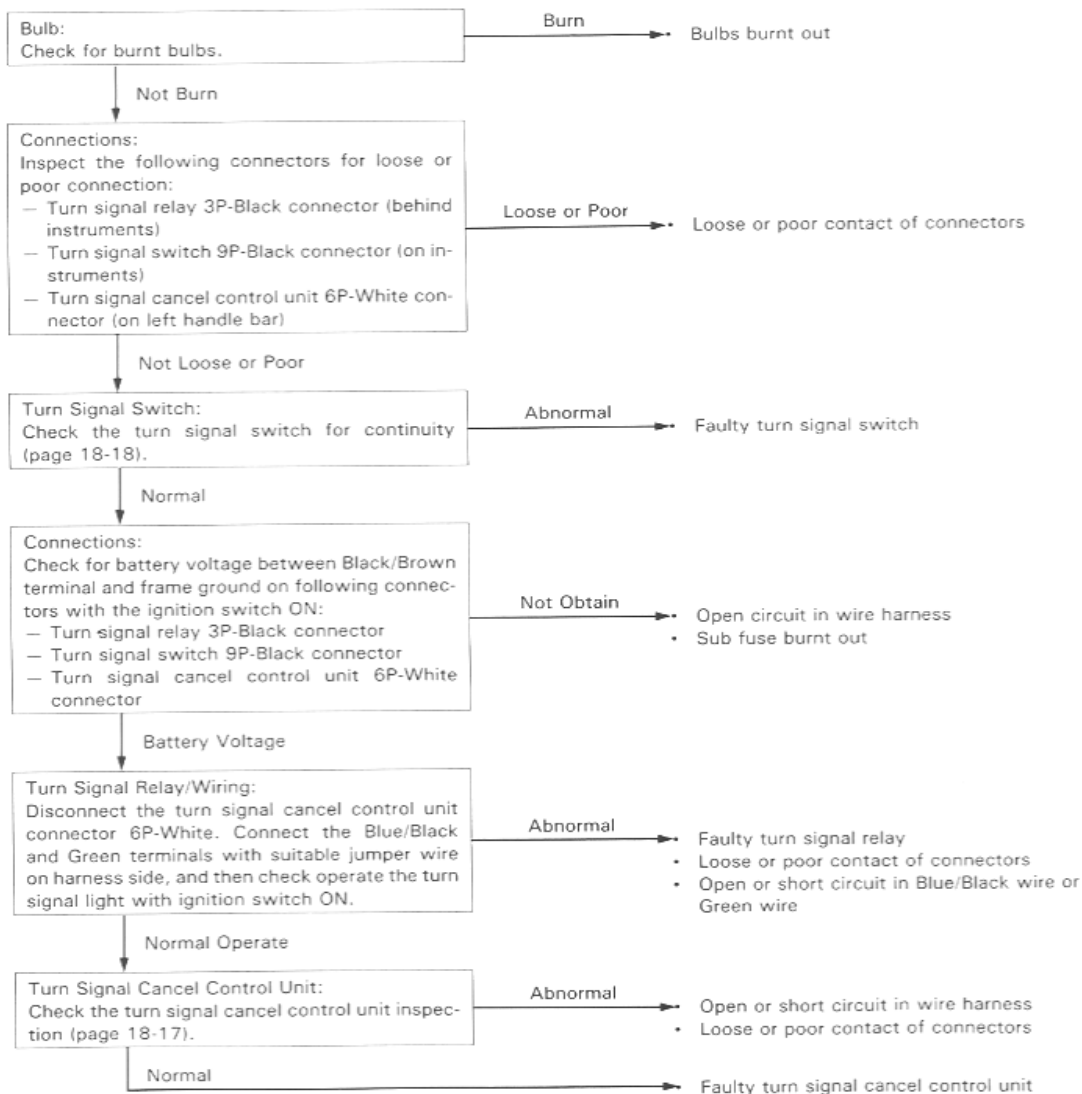

Turn signals are not cancelled automatically.

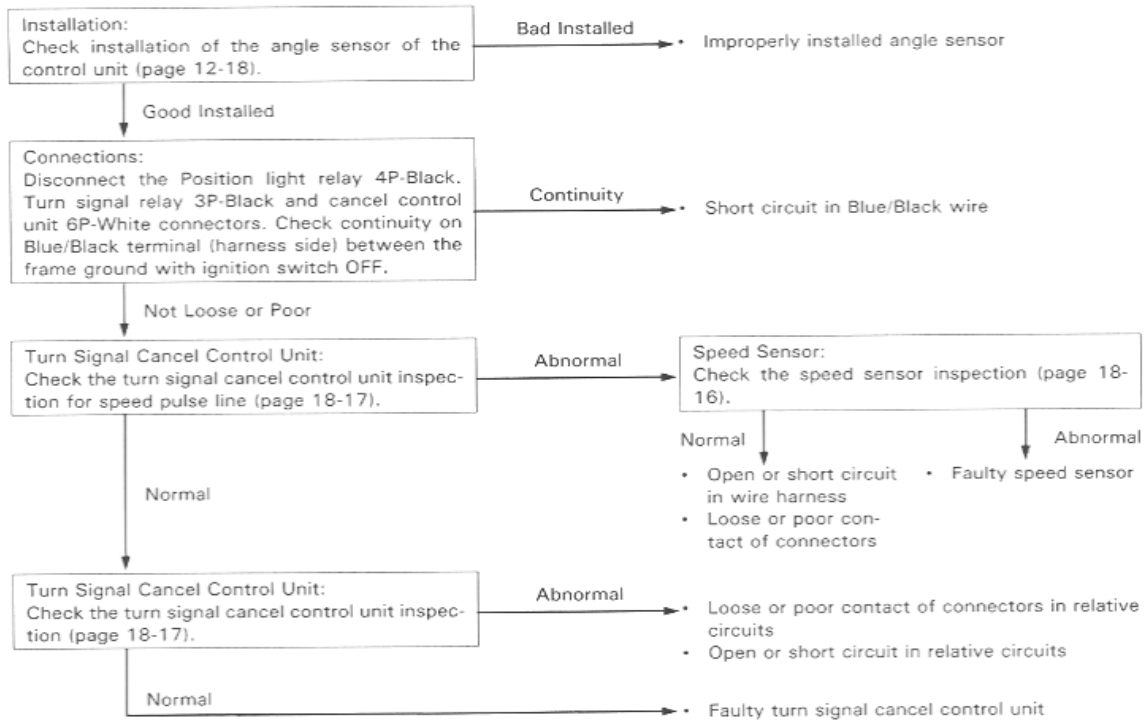

## Lights/Meters/Switches

On parking, when the front wheel is turned slowly from left to right, turn signals is cancelled.

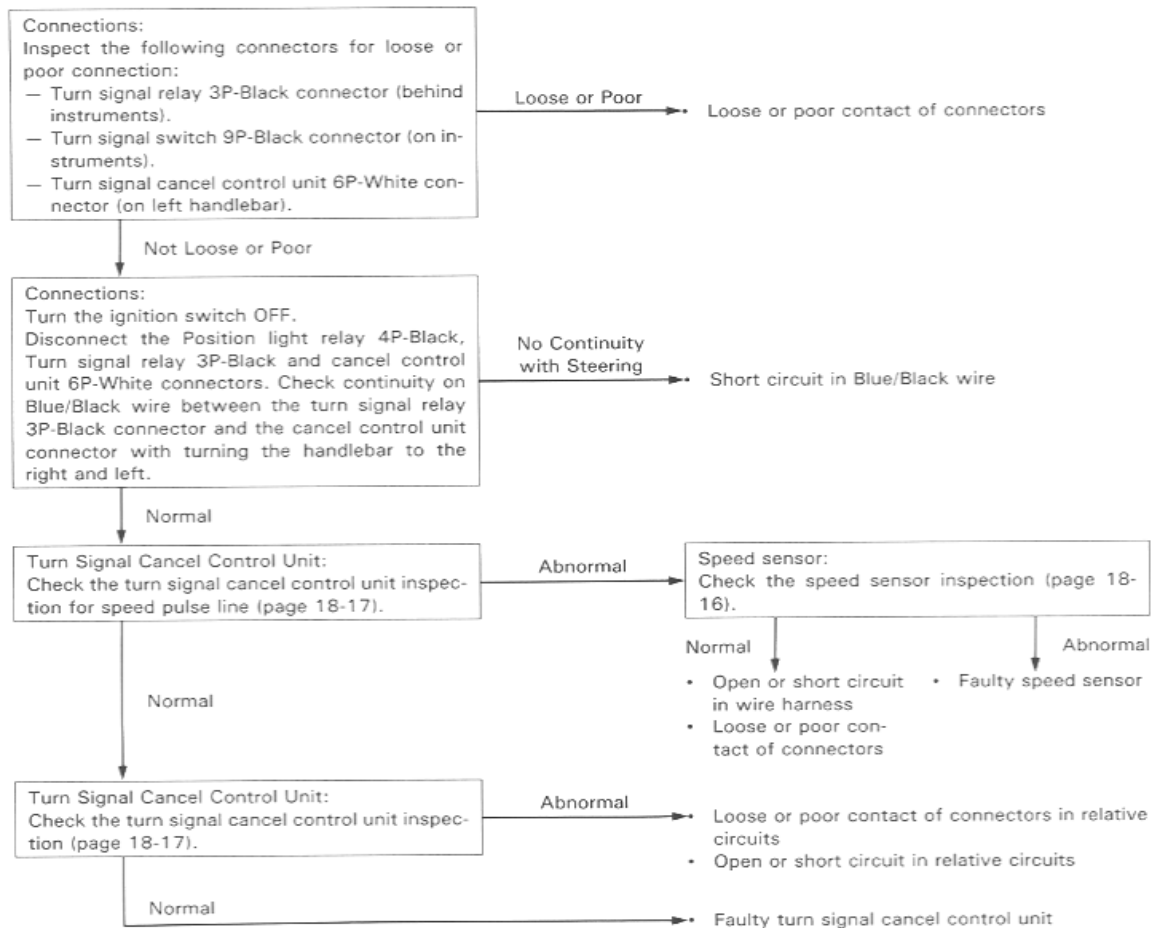

Turn signals do not cancel manually.

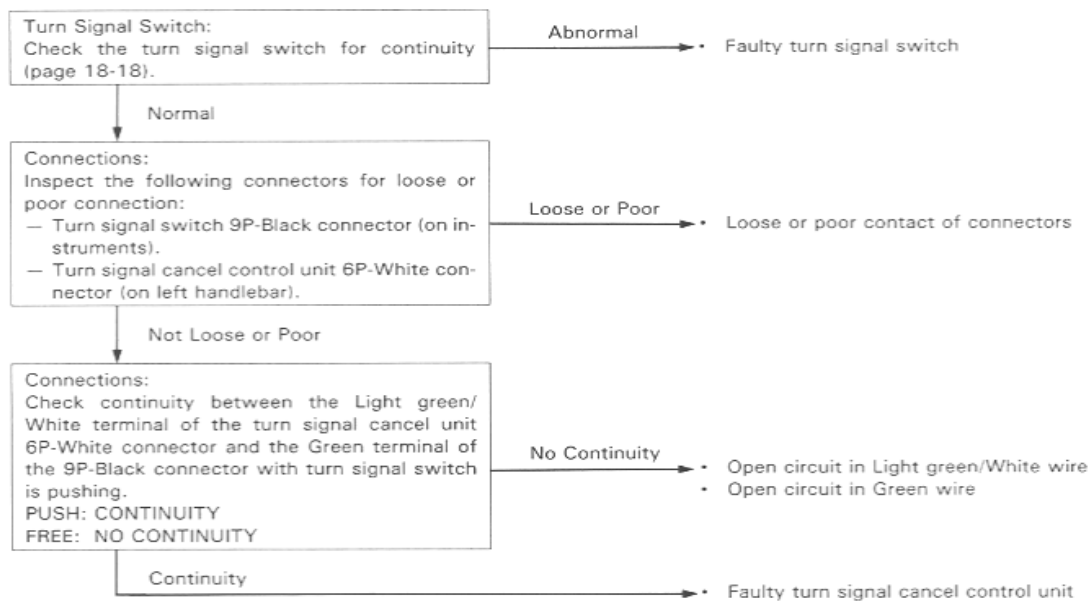

## Headlight

### Bulb Replacement

Remove the windshield and screen air duct (Section 2).

Remove the headlight connector and dust cover.  
Remove the headlight bulb by removing the bulb retainer.

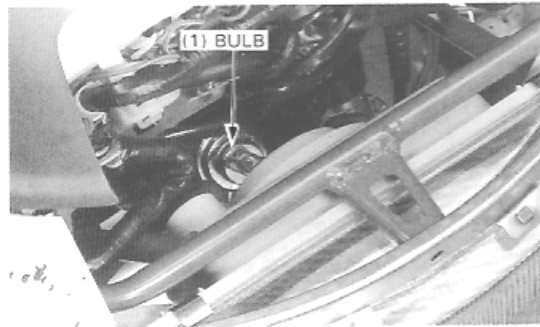

Install a new headlight bulb.

#### CAUTION

- If you touch the bulb with your bare hands, clean it with a cloth moistened with alcohol to prevent early failure.

#### NOTE

- Install the dust cover with its "TOP" mark facing up.

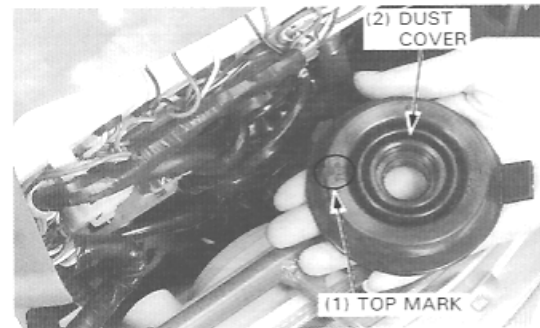

## Front Turn Signal

### Bulb Replacement

Remove the rear-view mirror (Section 2).

Remove the turn signal light mounting screw and turn signal light.

Remove the bulb and socket as an assembly by turning it counterclockwise.

Remove the bulb from the socket by turning it counterclockwise.

Install a new bulb onto the bulb socket and install it by turning it clockwise.

#### NOTE

- Check that the rubber seal is in good condition and replace it if necessary.

Install the turn signal light by mounting screw.

Install the rear-view mirror (Section 2).

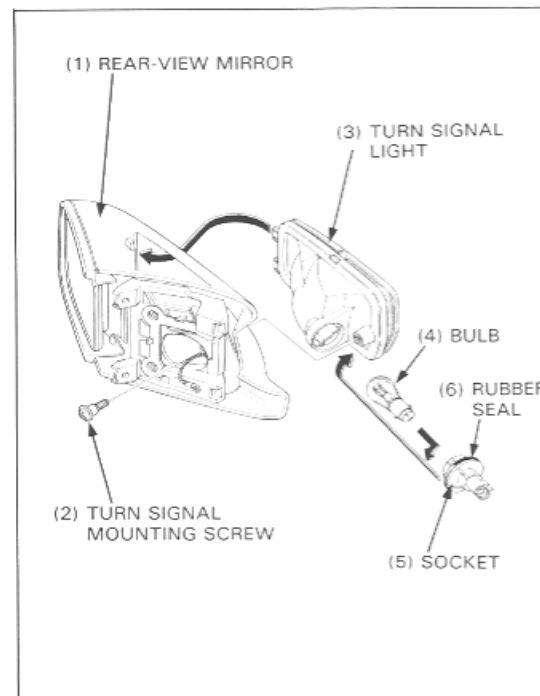

## Rear Turn Signal

### Removal

Open the trunk lid and remove the brake and taillight assembly (Section 2).

Remove the turn signal mounting bolt and turn signal body.

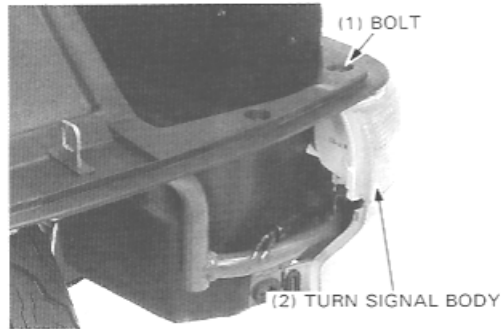

### Bulb Replacement

Remove the turn signal bulb and socket as an assembly by turning it counterclockwise.

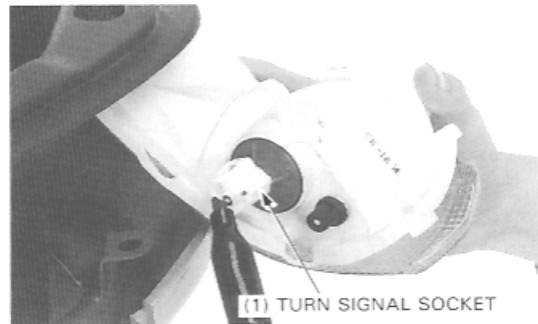

Remove the bulb by turning it counterclockwise.

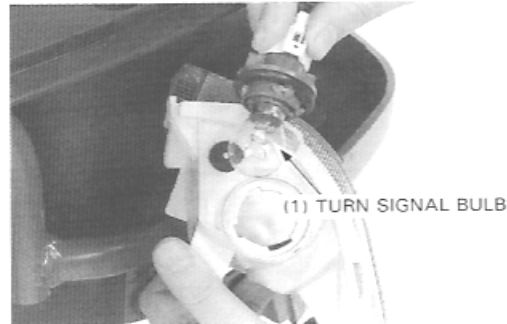

Replace a new turn signal bulb and install it in the reverse order of removal.

### NOTE

- Check that the rubber seal is in good condition and replace it if necessary.

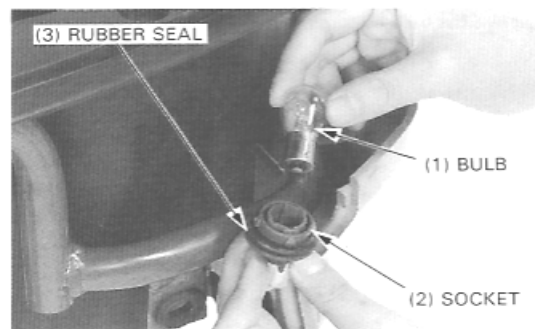

**Installation**

Install the turn signal, aligning the body boss with the hole.

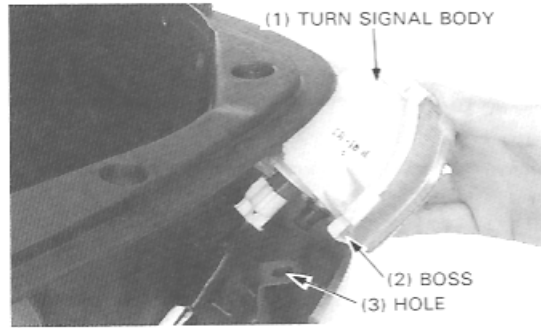

Install the mounting bolt onto the turn signal body.

Torque: 7 N·m (0.7 kg·m, 5 ft·lb)

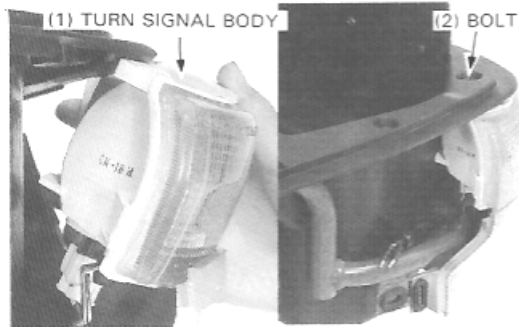

**Brake and Taillight**

**Bulb Replacement**

Open the trunk lid and remove the brake and taillight assembly (Section 2).

Remove the brake and taillight bulb and socket as an assembly by turning it counterclockwise.



Remove the bulb by turning it counterclockwise.

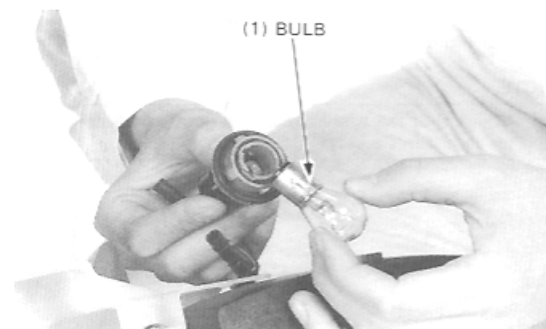

Replace a new brake and taillight bulb and install it in the reverse order of removal.

**NOTE**

- Check that the rubber seal is in good condition and replace it if necessary.

Torque: 7 N·m (0.7 kg·m, 5 ft·lb)

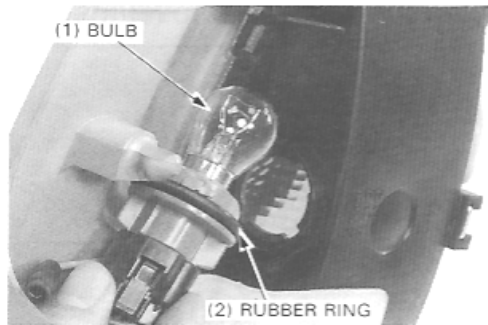

## License Light

### Bulb Replacement

Open the trunk lid and remove the rear fender assembly (Section 2).

Disconnect the license light connector from the socket.



Remove the license light bulb and socket as an assembly by turning it counterclockwise.

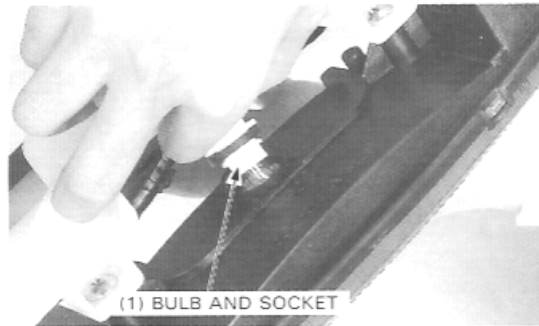

Pull the bulb out of the bulb socket.

Replace it with a new one and install it in the reverse order of removal.

**NOTE**

- Check that the rubber seal is in good condition and replace it if necessary.

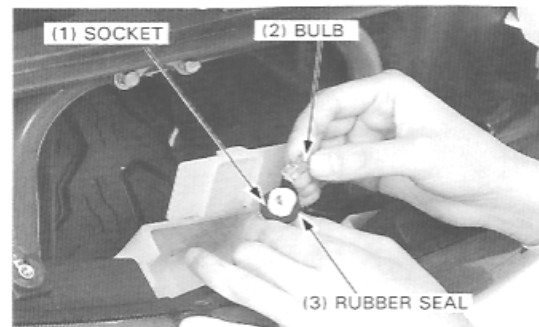

### Combination Meter Removal/Installation

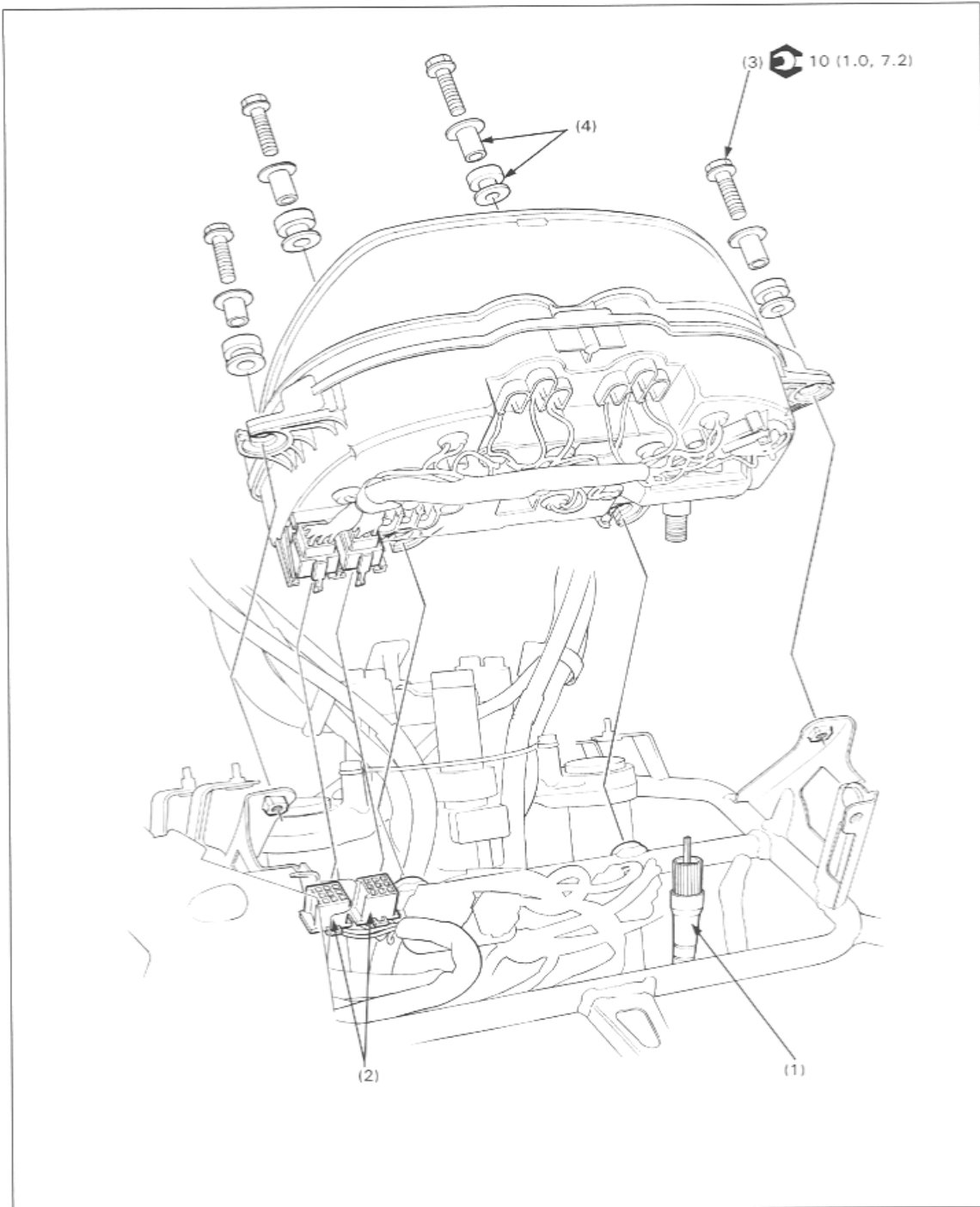

18-12

**Requisite Service**

- Meter visor removal/installation (Section 2)

Procedure		Q'ty	Remarks
	<b>Removal Order</b>		Installation is in the reverse order of removal.
(1)	Speedometer cable	1	Disconnect the cable from the meter.
(2)	Connector	2	Disconnect the 9P White and Black connectors.
(3)	Meter mounting bolt	4	
(4)	Mounting collar and rubber	4	At installation: install the rubber into the meter mounting hole securely first, then insert the collar onto the rubber.

## Combination Meter Disassembly/Assembly

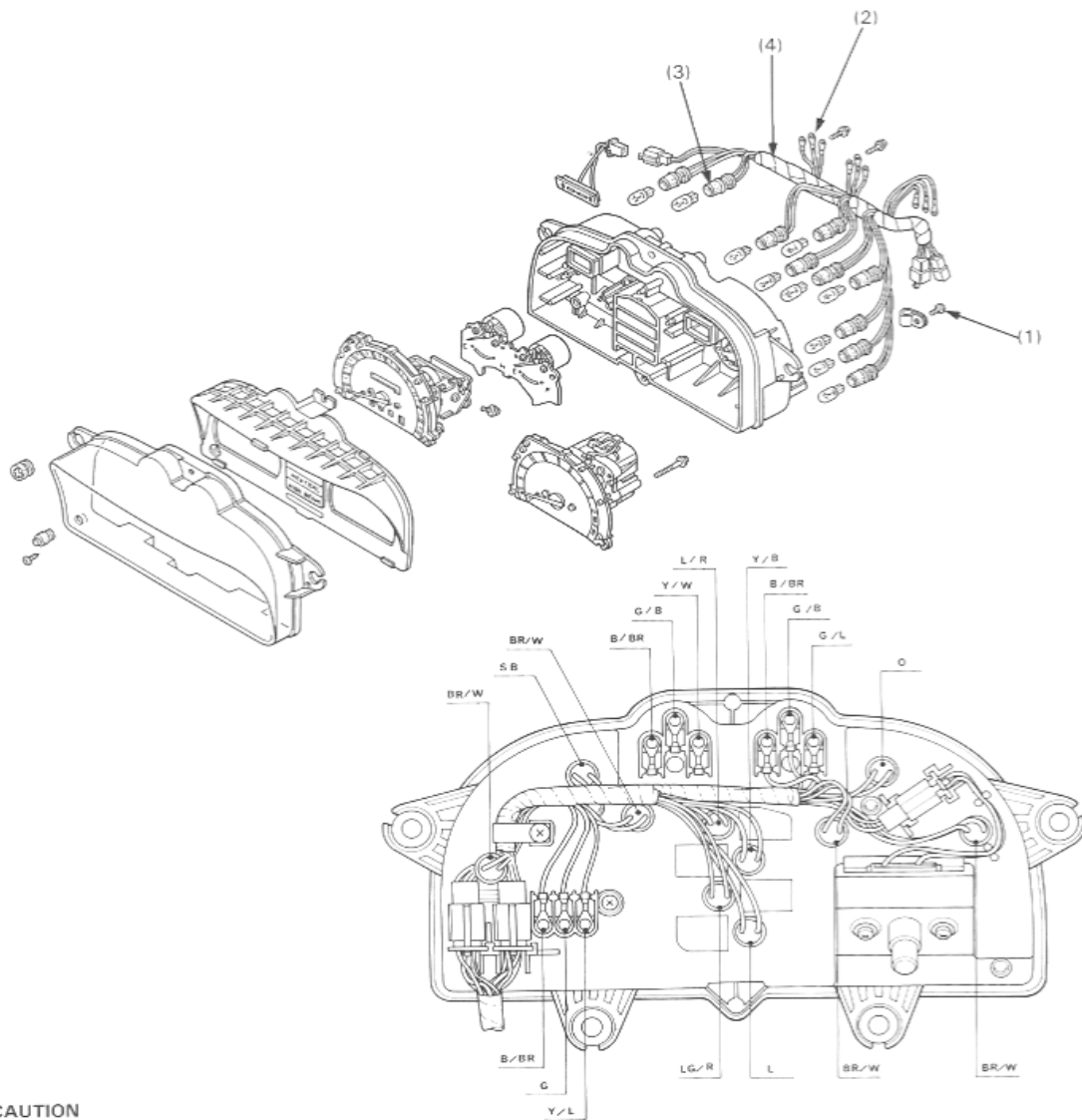

**CAUTION**

- The only purpose of this color chart is for the combination meter wire harness connection.

CODE	WIRE COLOR	CODE	WIRE COLOR
BR	BROWN	Y	YELLOW
W	WHITE	L	BLUE
SB	LIGHT BLUE	R	RED
B	BLACK	O	ORANGE
G	GREEN	LG	LIGHT GREEN

NOTE

- Connect the terminals and install the sockets according to the color codes indicated on the back panel. The color codes (on 18-14 page) are for connection of the combination meter wire harness.
- Route the wire harness as illustration shown.

**Requisite Service**

- Combination meter removal (page 18-12)

	Procedure	Q'ty	Remarks
	<b>Removal Order</b>		Installation is in the reverse order of removal.
(1)	Wire clump/screw	1	
(2)	Wire harness terminal	9	Remove the terminal screws and disconnect the coad.
(3)	Meter bulb socket	10	Pull the sockets and bulbs out of the back panel as an assembly.
(4)	Wire harness	1	Disconnect the speed sensor connector (2P-White) from the meter and remove the wire harness from the meter.

## Instruments

### Bulb Replacement

Remove the windshield and screen air duct (Section 2).

Pull the bulb and socket out of the meter as an assembly.

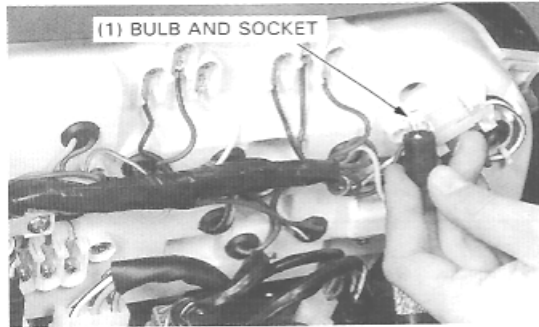

Pull the bulb out of the bulb socket.

Replace the bulb with a new one and install the bulb/socket assembly in the reverse order of removal.

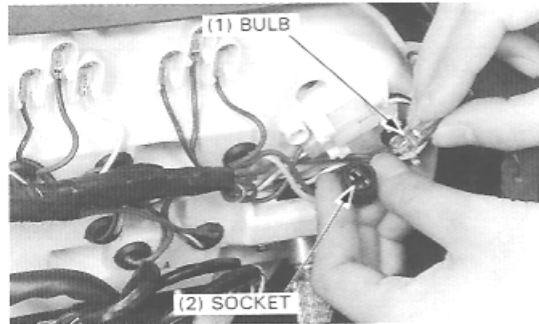

### Speed Sensor Inspection

Check the speedometer cable for loose connection.

Disconnect the speedometer cable.

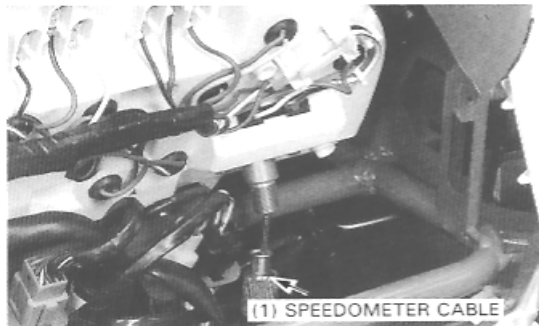

Connect an ohmmeter across the White/Black (+) and Green/Black (-) terminals of the sensor 2P-White connector.

The sensor is normal if the ohmmeter needle swings from 0 to  $\infty$  (infinity) slowly, four times, when the speedometer drive shaft is turned slowly one full turn.

**Standard: 4 Pulses/One Turn**

If there is not swing when turning the drive shaft, replace the speed sensor.

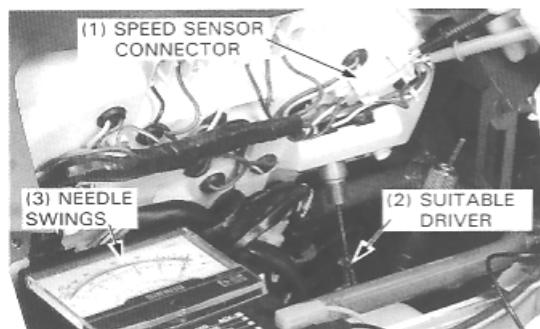

## Self-cancelling Turn Signal System ('89 - '90, '94 - '96)

### Unit Inspection (Input Signal Inspection)

**NOTE**

- Be sure the battery is fully charging.
- When inspecting this system, check the system components and lines step-by-step according to the troubleshooting chart on pages 18-3, 4, 5, 6.
- Check that sub fuse is not blown.

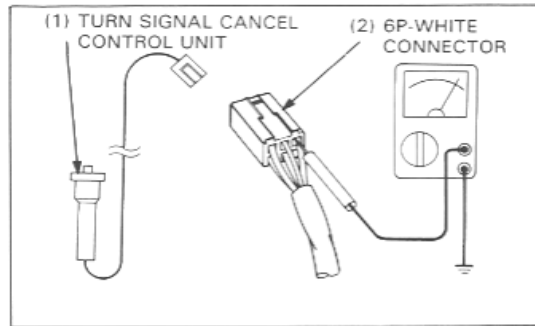

Disconnect the turn signal cancel control unit 6P-White connector from the unit.

Make the following measurements between each terminal of the main wire harness side and ground.

Line	Terminal	Condition (S)		Specification
Battery voltage (+) input	W/G	Ignition switch ON		Battery voltage should register
Turn signal ON	P	Turn signal switch R or L		Continuity should exist
		Turn signal switch PUSHED		No continuity
Turn signal OFF	Lg/W	Turn signal switch R or L		No continuity
		Turn signal switch PUSHED		Continuity should exist
Speed pulse signal from the speed sensor	W/BI	Front wheel rotated slowly Ignition switch ON		0 - ∞ (Continuity to no continuity while the front wheel rotation.) Pulse obtained
Cancel signal output	Bu/BI	Ignition switch ON 6P-White connector connected	Turn signal switch operated in L or R	0 volts should register
			Turn signal switch PUSHED	Battery voltage should register
Ground	G	At all times		Continuity should exist

### Position Light Relay Inspection

Connect a 12 V battery as shown and check for continuity between the indicated terminals.

Terminals	Connect a battery	Disconnect a battery
Lb/W - O/W	No continuity	Continuity

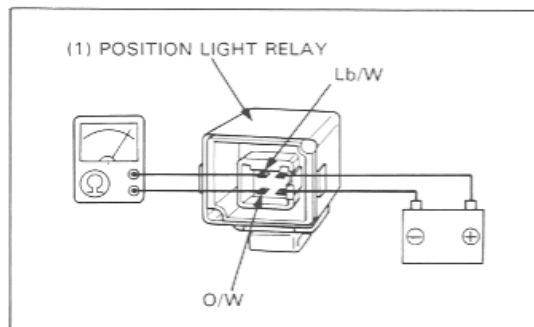

## Lights/Meters/Switches

### Turn Signal Switch Inspection

	W	R	L	TL1	PR	PL	E	W (On)	E	W (Off)
R	○	○		○		○	◇	◇		
L	○		○	○	○		◇	◇		
Push									△	△
Color	Gr	Lb	O	Br/W	Lb/W	O/W	G	P	G	Lg/W

- : CONTINUITY, except while the switch lever is pushed.  
 ◇—◇: CONTINUITY, while holding the switch lever in the L, or R, positions.  
 △—△: CONTINUITY, while pushing the switch lever.

#### Inspect as Following:

- Check continuity between the Gr (Turn signal relay 3P) and Lb (Turn signal switch 9P):  
 Check continuity between the Gr (Turn signal relay 3P) and O (Turn signal switch 9P):  
  
 Once the turn signal switch has been turned to the L or R position, it has CONTINUITY, except when the switch lever is pushed.
- Check continuity between the Br/W (Turn signal switch 9P) and Lb/W (Turn signal switch 9P):  
 Check continuity between the Br/W (Turn signal switch 9P) and O/W (Turn signal switch 9P):  
  
 Once the turn signal switch has been turned to the L or R position, it has CONTINUITY, except when the switch lever is pushed.
- Check continuity between the G (Turn signal switch 9P) and P (Turn signal cancel control unit 6P):  
  
 There should be CONTINUITY while holding the turn signal switch in the L or R turn position.
- Check continuity between the G (Turn signal switch 9P) and Lg/W (Turn signal cancel control unit 6P):  
  
 There should be CONTINUITY while pushing the turn signal switch.

#### Turn Signal Self-Cancel System Function Table

Speed	0 km/h (0 mph)	1 – 67 km/h (1 – 43 mph)	Over 67 km (Over 43 mph)
Turn Signal Cancel System Function	Continued:	Self-cancelled: after 108 – 132 m (354 – 433 feet) have been ridden from the latest straight position.	Self-cancelled: 6.3 – 7.7 seconds later from the turn signal switch ON.

## Ignition Switch Removal/Installation

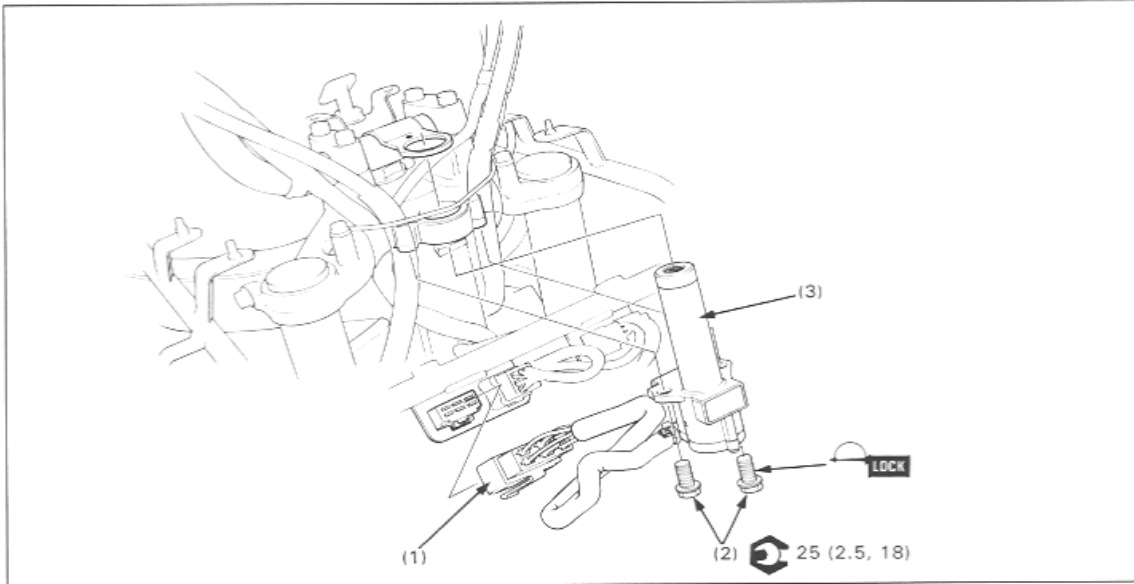

### Requisite Service

- Handlebar center cover removal (Section 2)

Procedure	Q'ty	Remarks
<b>Removal Order</b>		Installation is in the reverse order of removal. Disconnect the 6P White connector.
(1) Ignition switch connector	1	
(2) Ignition switch mounting bolt	2	
(3) Ignition switch	1	

## Side Stand Switch Removal/Installation

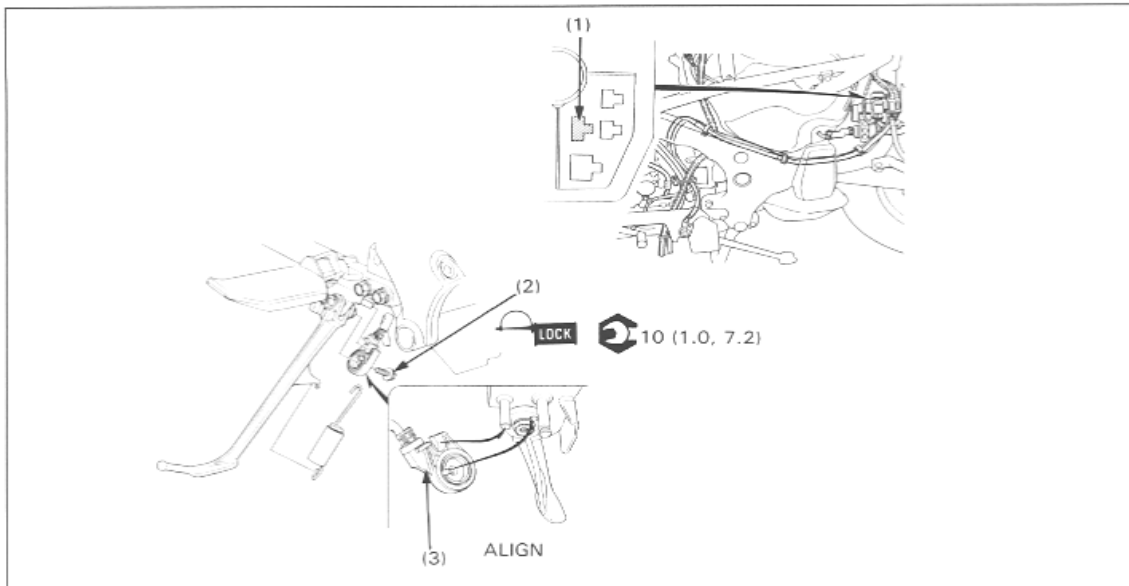

### Requisite Service

- Support the motorcycle on its center stand
- Left lower cover removal (Section 2)

Procedure	Q'ty	Remarks
<b>Removal Order</b>		Installation is in the reverse order of removal.
(1) Side stand switch connector	1	Disconnect the 3P-Green connector from the connector bracket and unhook the side stand switch wire.
(2) Side stand switch bolt	1	Apply a locking agent.
(3) Side stand switch	1	At installation: Align the boss and stop pin with the side stand.

## Side Stand Switch Inspection

Disconnect the side stand 3P green connector beside the fuel tank and check for continuity between each terminal as shown below.

There should be continuity between the ○—○ positions on the continuity chart.

	Green/ White	Yellow/ Black	Green
Side stand is down		○—○	○
Side stand is up	○—○		○

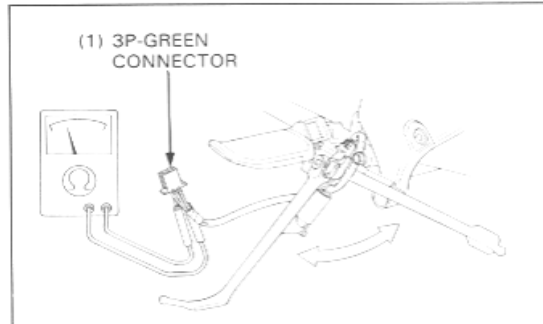
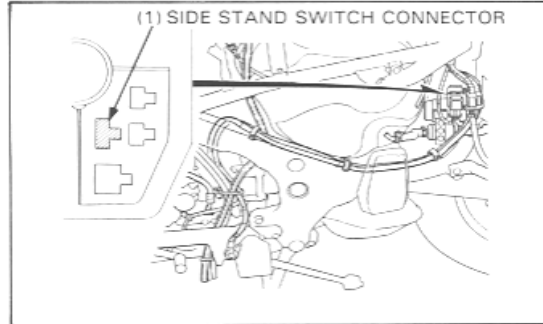

## Fuel Pump and Fuel Filter Removal/Installation

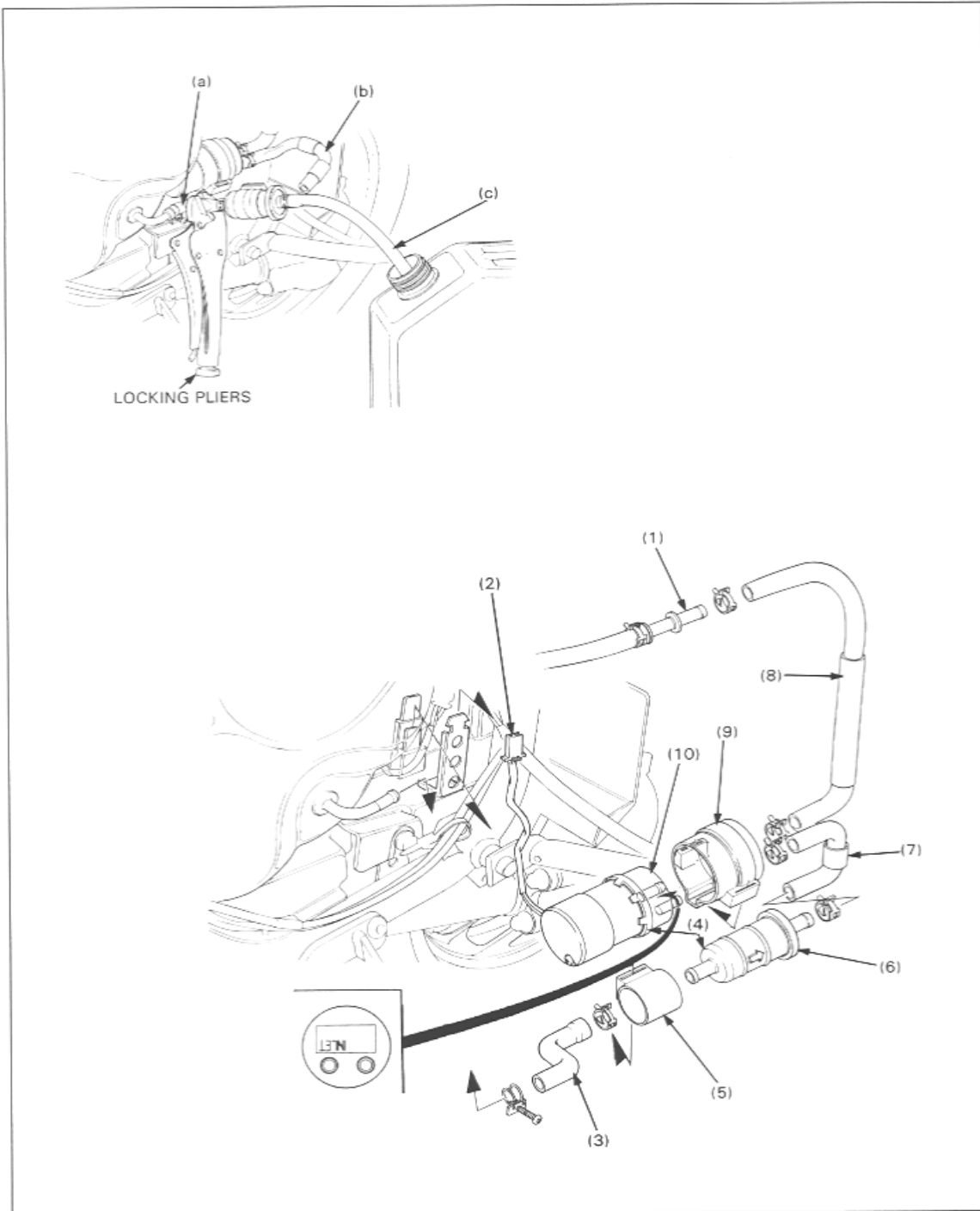

**▲ WARNING**

- Gasoline is extremely flammable and is explosive under certain conditions. Refuel in a well-ventilated area with the engine stopped. Do not smoke or allow flames or sparks in your working area.
- Keep away from flames or sparks. Wipe up spilled gasoline at once.

**Requisite Service**

- Left lower cover removal (Section 2)
- Open the trunk lid

Procedure		Q'ty	Remarks
<b>Fuel Tank Draining Procedure</b>			
(a)	Fuel tank tube	1	Clamp the fuel tank tube with locking pliers or equivalent.
(b)	Filter to pump tube	1	Disconnect the filter to the pump tube.
(c)	Suitable hose	1	Connect a suitable hose to the filter outlet. Unclamp and drain the fuel into a clean container.
<b>Removal Order</b>			
(1)	Fuel tube joint	1	Installation is in the reverse order of removal. Disconnect the fuel feed tube joint above the fuel tank.
(2)	Fuel pump connector	1	Disconnect the 2P Black connector from the bracket.
(3)	Fuel tank tube	1	Loosen the tube band screw and disconnect the tube from the tank nozzle.
(4)	Fuel pump and filter	2	Remove the fuel pump and filter as an assembly from the bracket.
(5)	Fuel filter rubber suspension	1	Remove it from the filter.
(6)	Fuel filter	1	At installation: Install the filter with its arrow pointing toward the outlet side (fuel pump side).
(7)	Fuel pump inlet tube	1	: Filter to pump
(8)	Fuel pump outlet tube	1	: Pump to carburetor
(9)	Fuel pump rubber suspension	1	
(10)	Fuel pump	1	

## Fuel Cut-off Relay

**⚠ WARNING**

- Gasoline is extremely flammable and is explosive under certain conditions. Work in a well ventilated area. Do not smoke or allow flames or sparks in the your work area or where gasoline is stored.

Open the trunk lid.  
 Check the sub-fuse (10 A).  
 Remove the relay from the rubber bracket and check the relay connector 3P-White terminals for looseness and corrosion.

**Inspect as Follows:**  
 Disconnect the connector and test the wires on the main harness side.

Item	Standard
Between BI (+) and body ground (-) with the ignition switch "ON"	Battery voltage should come.
Bu/Y wire between the pump relay and spark unit	Continuity
BI/Bu wire between the pump relay and fuel pump	Continuity

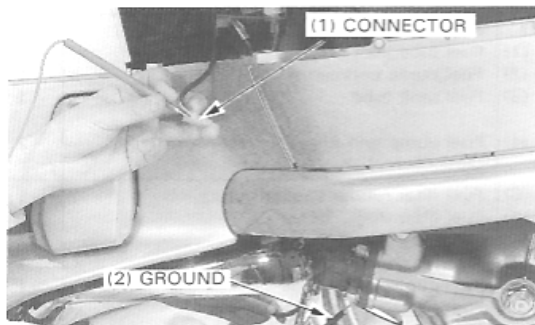
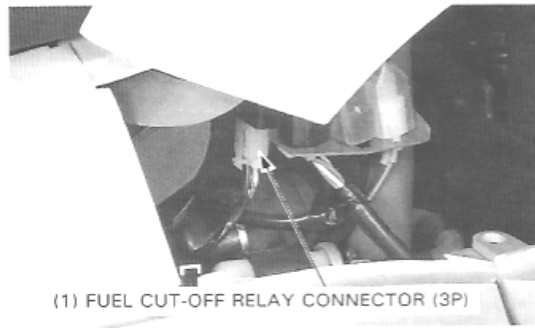

## Fuel Pump

### System Inspection

Turn the ignition switch OFF. Remove the seat and disconnect the fuel pump relay wire connectors. Short the Black and Black/Blue wire terminals with a jumper wire. Disconnect the fuel tube from the joint above the fuel tank and hold a graduated beaker under the fuel tube.

**⚠ WARNING**

- Gasoline is extremely flammable and is explosive under certain conditions. Work in a well ventilated area with the engine stopped. Do not smoke or allow flames or sparks in the work area or where gasoline is stored.

Turn the ignition switch ON and let fuel flow into the beaker for 5 seconds, then turn the ignition switch OFF. Multiply the amount in the beaker by 12 to determine the fuel pump flow capacity per minute.

**Fuel Pump Flow Capacity:**  
 600 cc (0.630 US qt. 0.528 Imp qt)/minute at 10 V

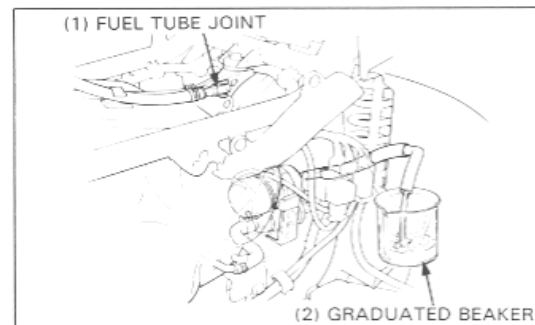
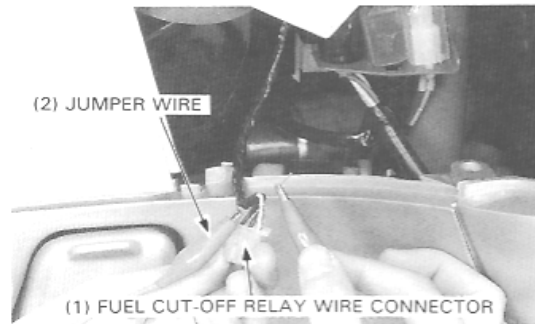

## Fuel Level Sensor Removal/Installation

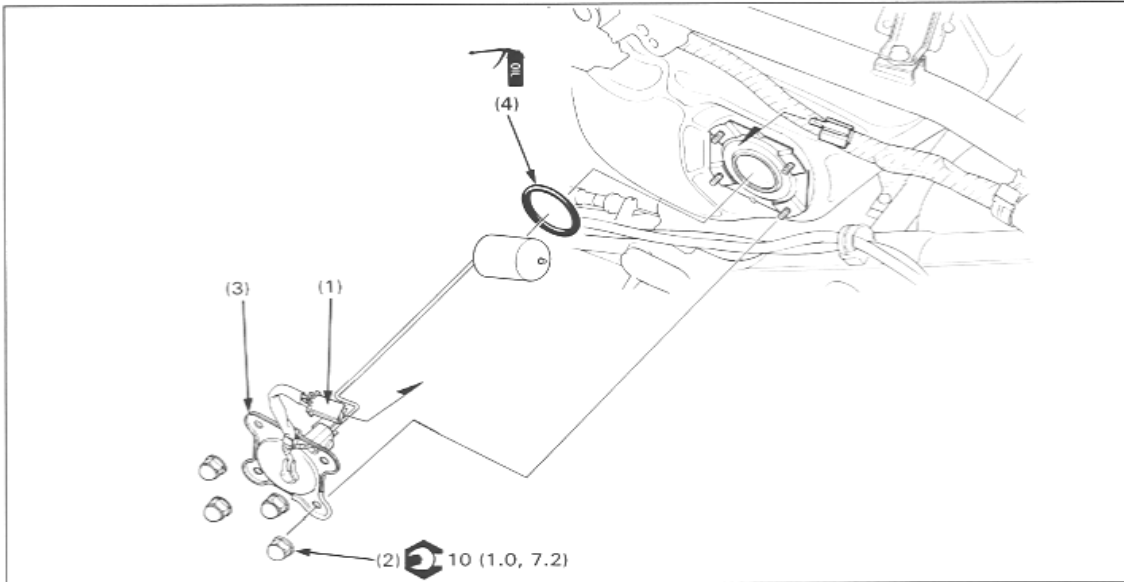

**▲ WARNING**

- Gasoline is extremely flammable and is explosive under certain conditions. Refuel in a well-ventilated area with the engine stopped. Do not smoke or allow flames or sparks in the area where the motorcycle is refueled or where gasoline is stored.
- Keep away from flames or sparks. Wipe up spilled gasoline at once.

### Requisite Service

- Right side cover removal/installation (Section 2)

Procedure	Q'ty	Remarks
<b>Removal Order</b>		Installation is in the reverse order of removal.
(1) Fuel level sensor connector	1	Disconnect the 2P Red connector.
(2) Sensor mounting nut	4	At installation: cap nut is located on lower-right.
(3) Fuel level sensor	1	
(4) O-ring	1	At installation: set the O-ring into groove firmly.

## Fan Motor Switch

Remove the front lower cowl (Section 2).  
The cooling fan motor is actuated by the fan motor switch located in the bottom of the radiator.

If the fan motor does not start, disconnect the Black/Blue lead from the fan motor switch and ground it with a jumper wire as shown.

Turn the ignition switch ON. The cooling fan motor should start running. If it does not start, check for battery voltage from the Black/Blue lead of the fan motor connector and ground with ignition switch ON.

If there is no voltage, check for a blown fuse, loose terminals or connectors, or an open circuit.

If there is voltage, inspect the fan motor switch as follows: Remove the switch.

Connect one lead of an ohmmeter to the connector of the fan motor switch and the other to the body.

Suspend the fan motor switch in a pan of coolant (50–50 mixture) and check the temperatures at which the switch opens and closes.

Make sure that there is no continuity at room temperature and then gradually raise the coolant temperature. The switch should show continuity (closed) at 93°–97°C (199°–207°F).

### NOTE

- Keep the temperature constant for 3 minutes to confirm continuity.  
A sudden change of temperature will cause error temperature reading between the thermometer and switch.
- Do not let the switch or thermometer touch the pan as it will give a false reading.
- Immerse the switch in coolant up to its threads.

Install a new O-ring on the switch.  
Apply sealant to the switch threads and install it.  
Tighten the switch to the specified torque.

**Torque: 18 N·m (1.8 kg·m, 13 ft·lb)**

### NOTE

- Do not over tighten the switch.

## Thermo Sensor

Remove the right air duct/maintenance lid (Section 2).

Disconnect the Green/Blue wire from the thermo sensor.  
Check for continuity between the sensor body and ground. There should be continuity.

If there is no continuity, check the thermostat housing for looseness and recheck. If there is still no continuity, remove the thermo sensor from the thermostat housing.

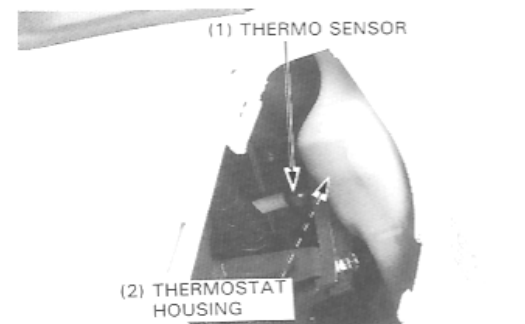
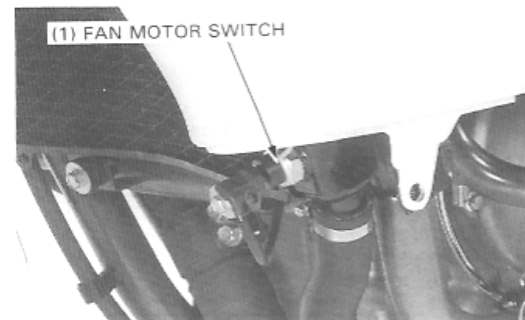
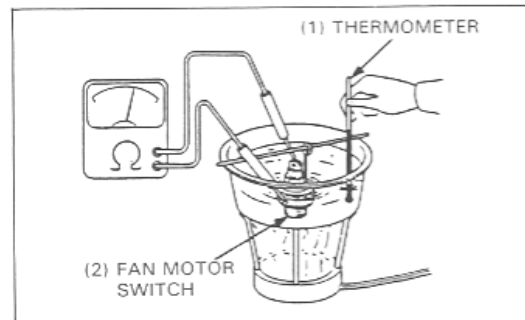
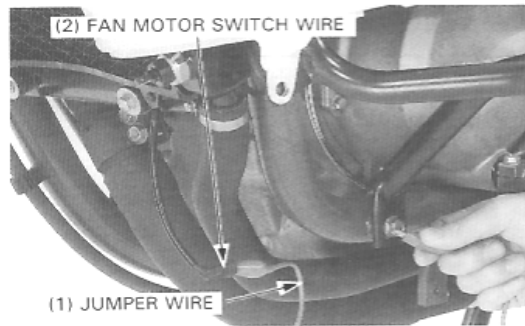

Suspend the thermo sensor in a pan of coolant over a heater and measure the resistance through the sensor as the coolant heats up.

Temperature	50°C (122°F)	100°C (212°F)
Resistance	130–180 Ω	25–30 Ω

**WARNING**

- Wear gloves and eye protection.

**NOTE**

- Coolant must be used as the heated liquid to check the function above 100°C (212°F).
- You will get false readings if either the sensor or thermometer touches the pan.

Replace the sensor if it is out of specification by more than 10% at either temperature.  
Thermo sensor replacement is refer to 6-7.

## Temperature Gauge

Disconnect the wire from the thermo sensor and short it to ground.

Turn the ignition switch ON. The temperature gauge needle should move all the way to (H).

**CAUTION**

- Do not leave the thermo sensor wire grounded for longer than a few seconds or the temperature gauge will be damaged.

Replace the temperature gauge with a new one if necessary.

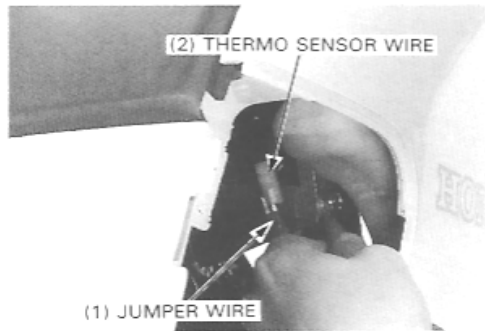
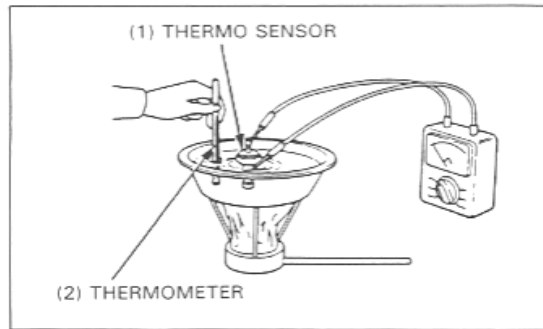



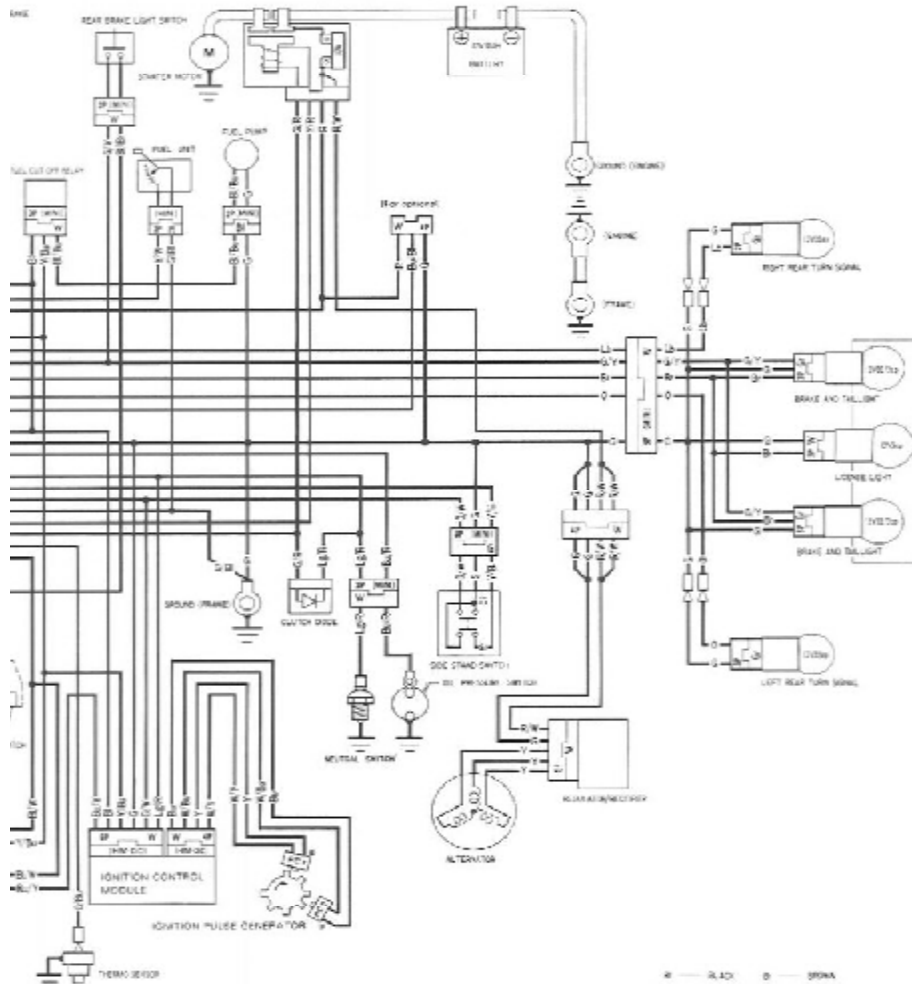

19

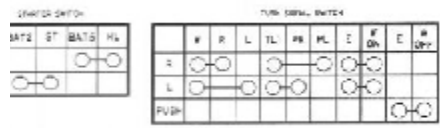

Refer to 18-15 page.

0030Z-MR5-6700

# Wiring Diagram

'90, '94 - '96

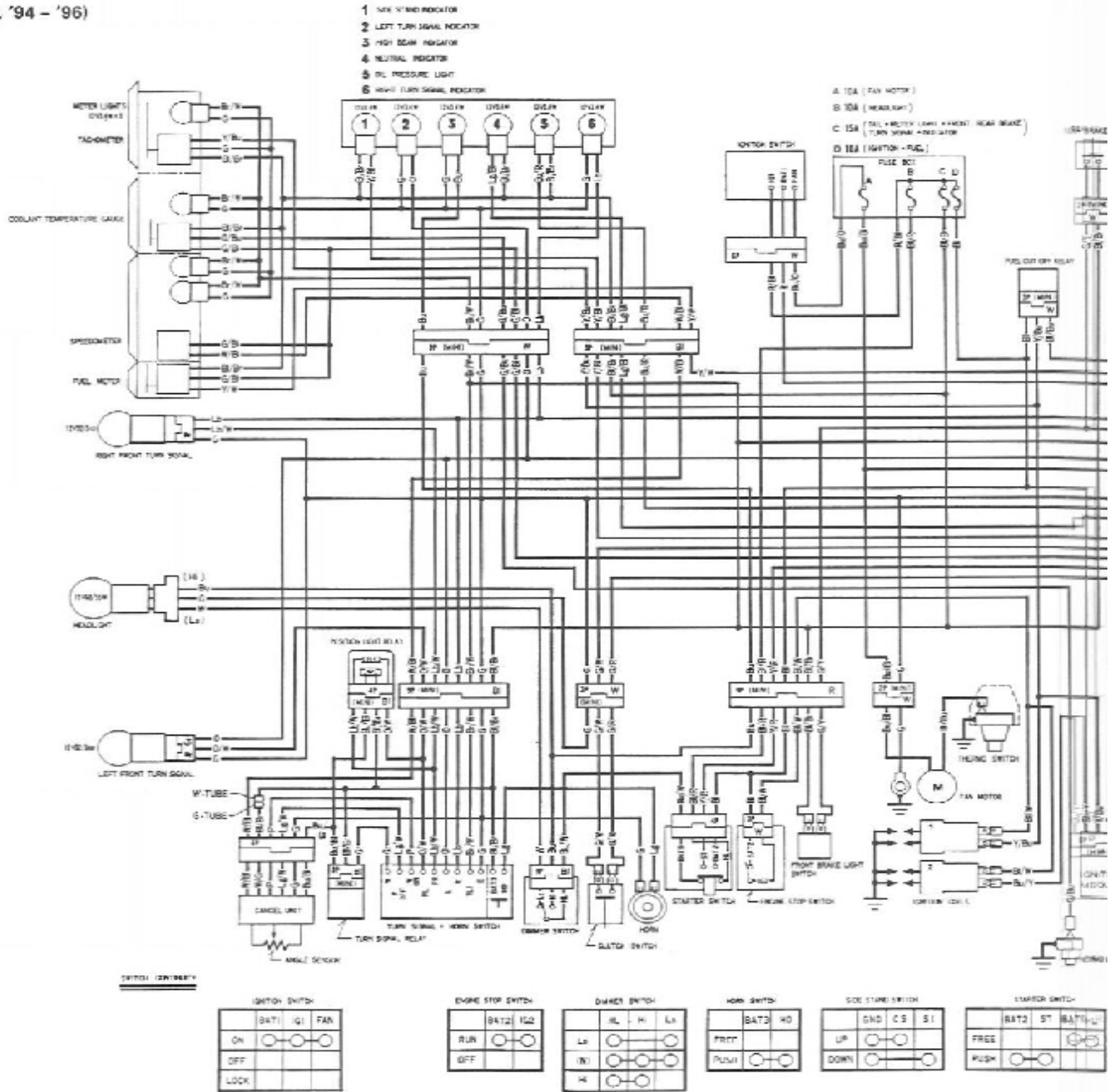

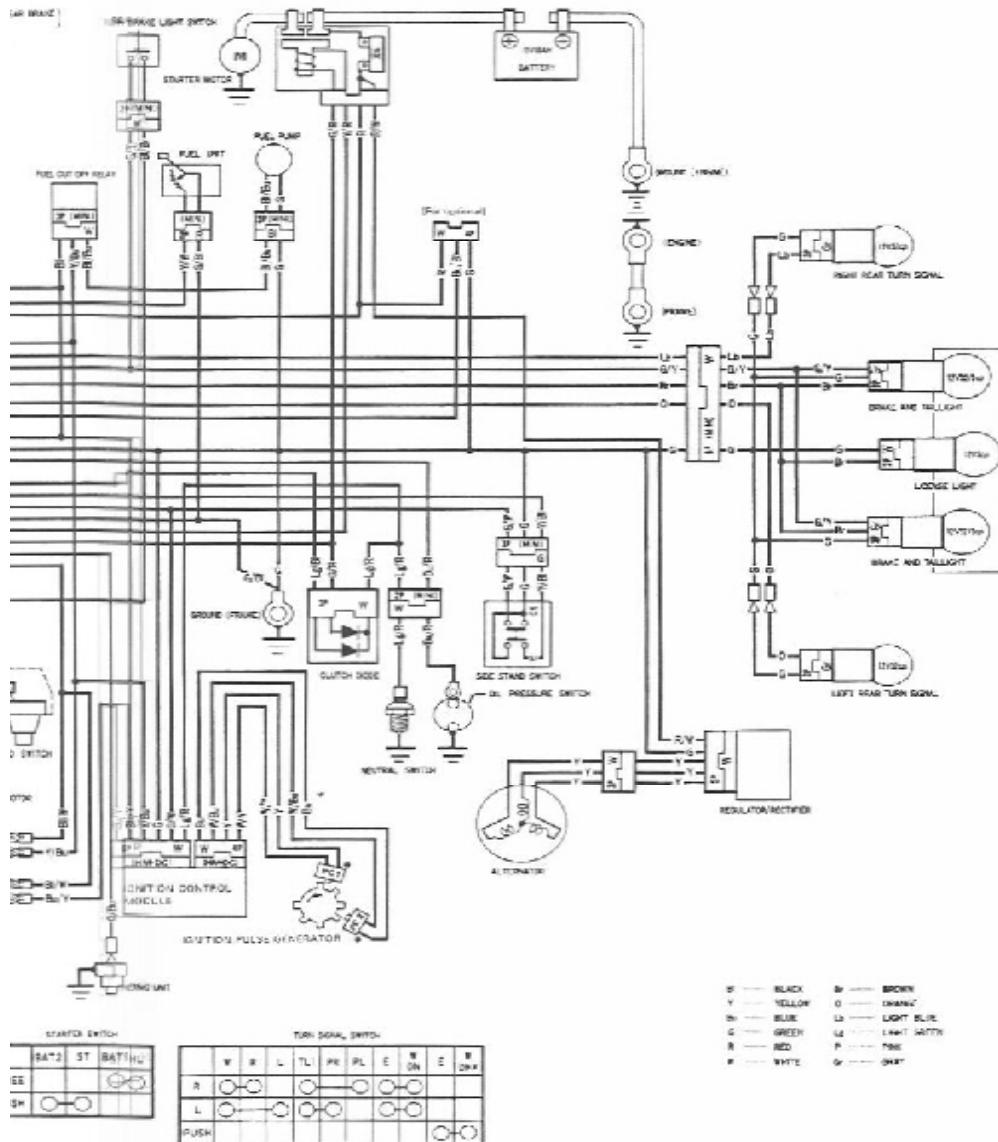

0030Z-MR5-8700

[After '96]

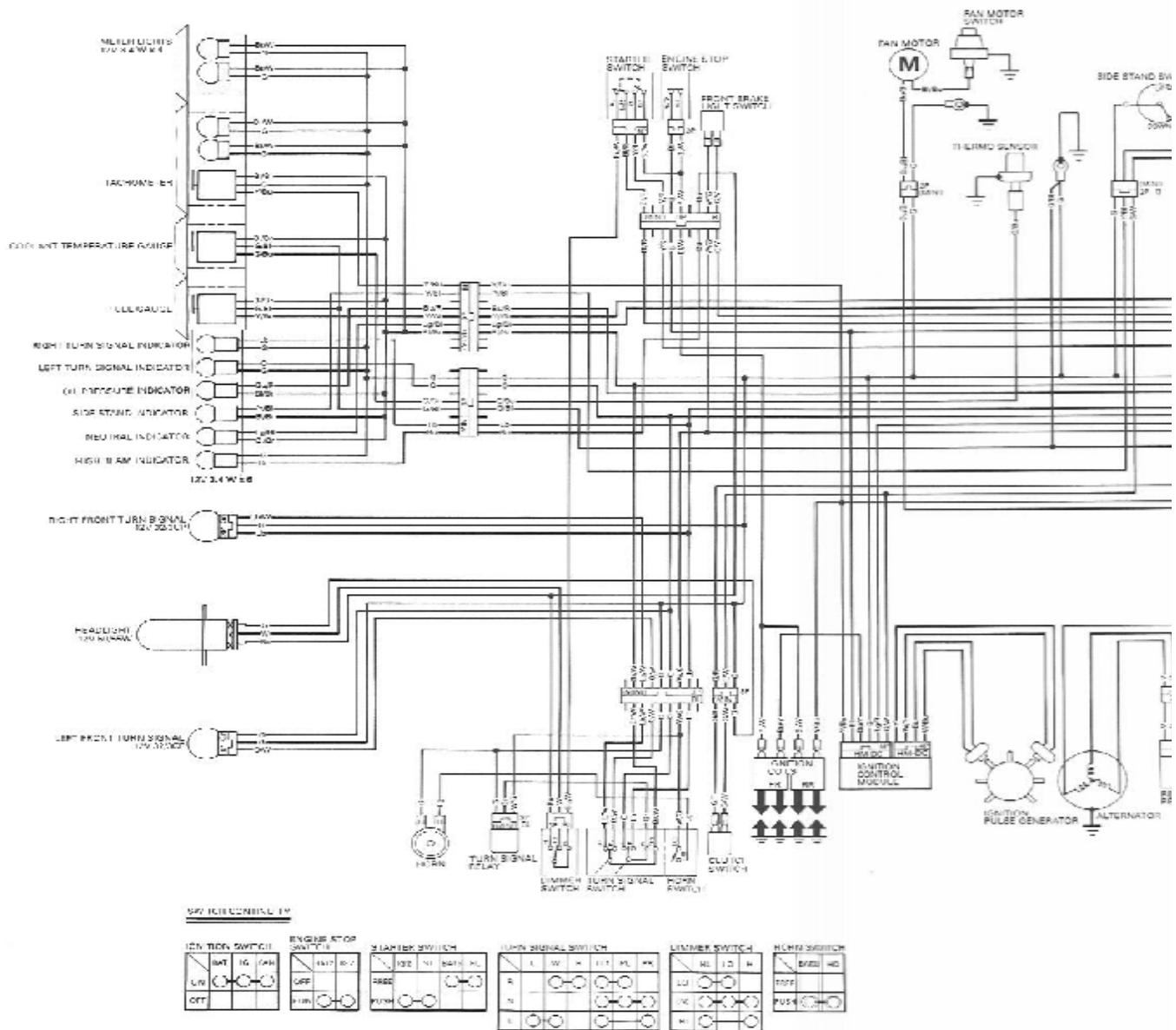

Wiring Diagram

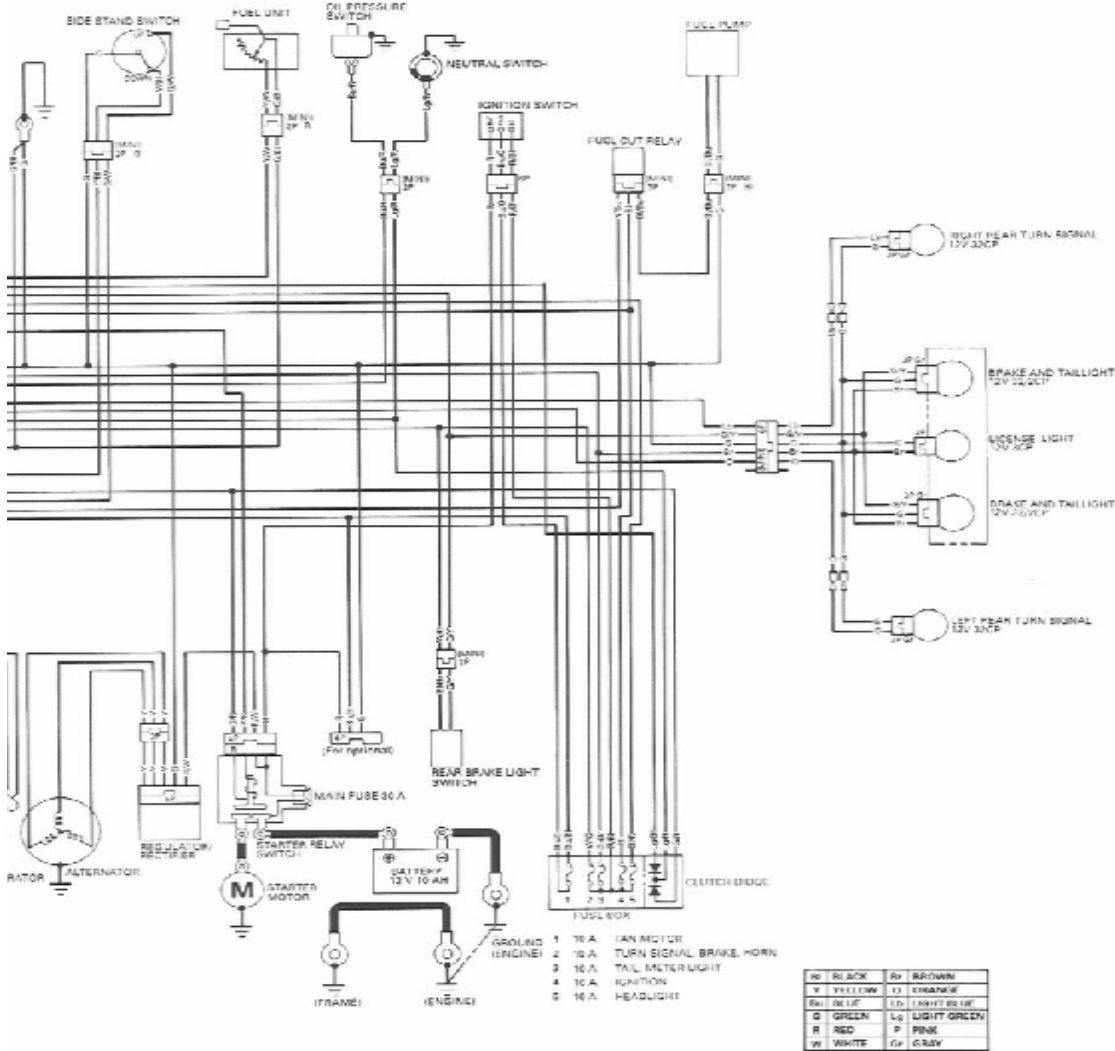

0030Z-MR5-A300

---

## 20. Technical Feature

### Fully Sealed Engine Cover System

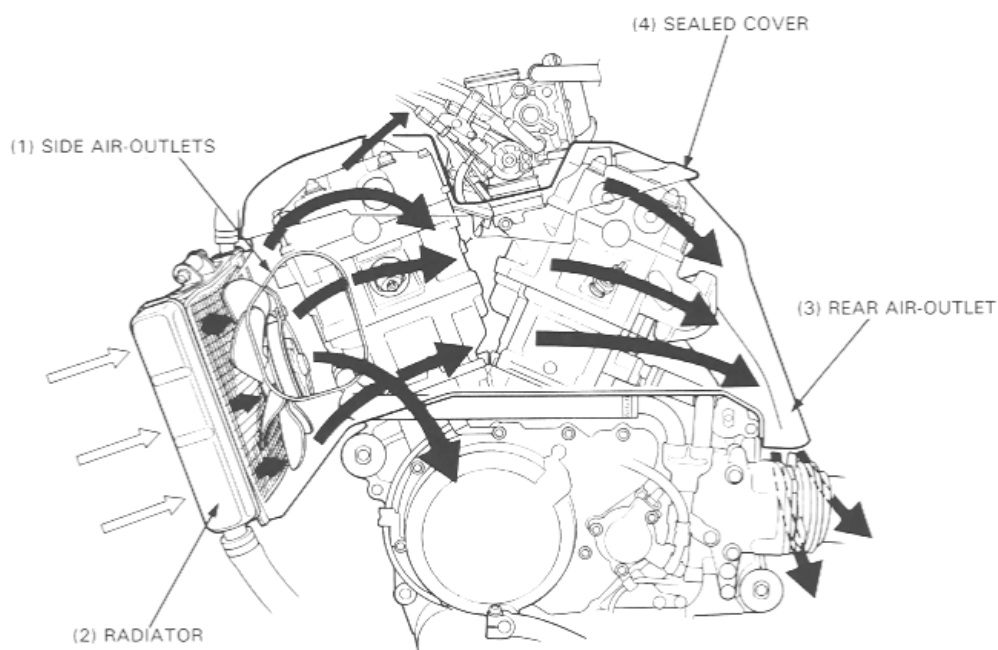

In addition to the benefits of a traditional fairing system, the integrated heat guard engine cover system provides rider/passenger isolation from engine heat. Both heat and mechanical noise from the engine are isolated by this sealed engine cover system that contributes to comfortable riding.

20

The engine covers also isolate the engine heat away from the carburetors.

A direct draft of air passes through an extra-large engine coolant radiator. The heated air escapes through front air outlets on both sides of the fairing.

The inner sealed covers direct hot air away through the rear air-outlet.

# 21. Troubleshooting

Engine Does Not Start or is Hard to Start	21-1	Poor Performance at High Speed	21-3
Engine Lacks Power	21-2	Poor Handling	21-4
Poor Performance at Low and Idle Speeds	21-3	Hydraulic Tappet	21-4

## Engine Does Not Start or is Hard to Start

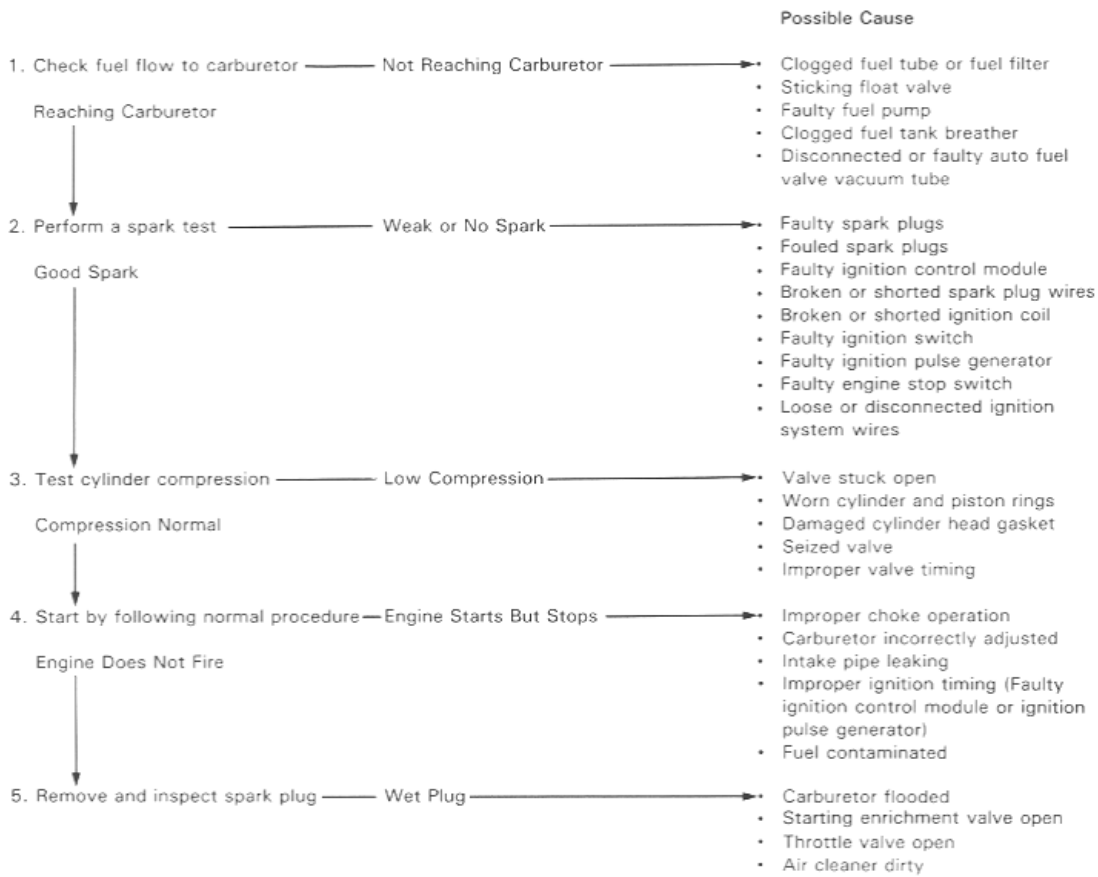

## Engine Lacks Power

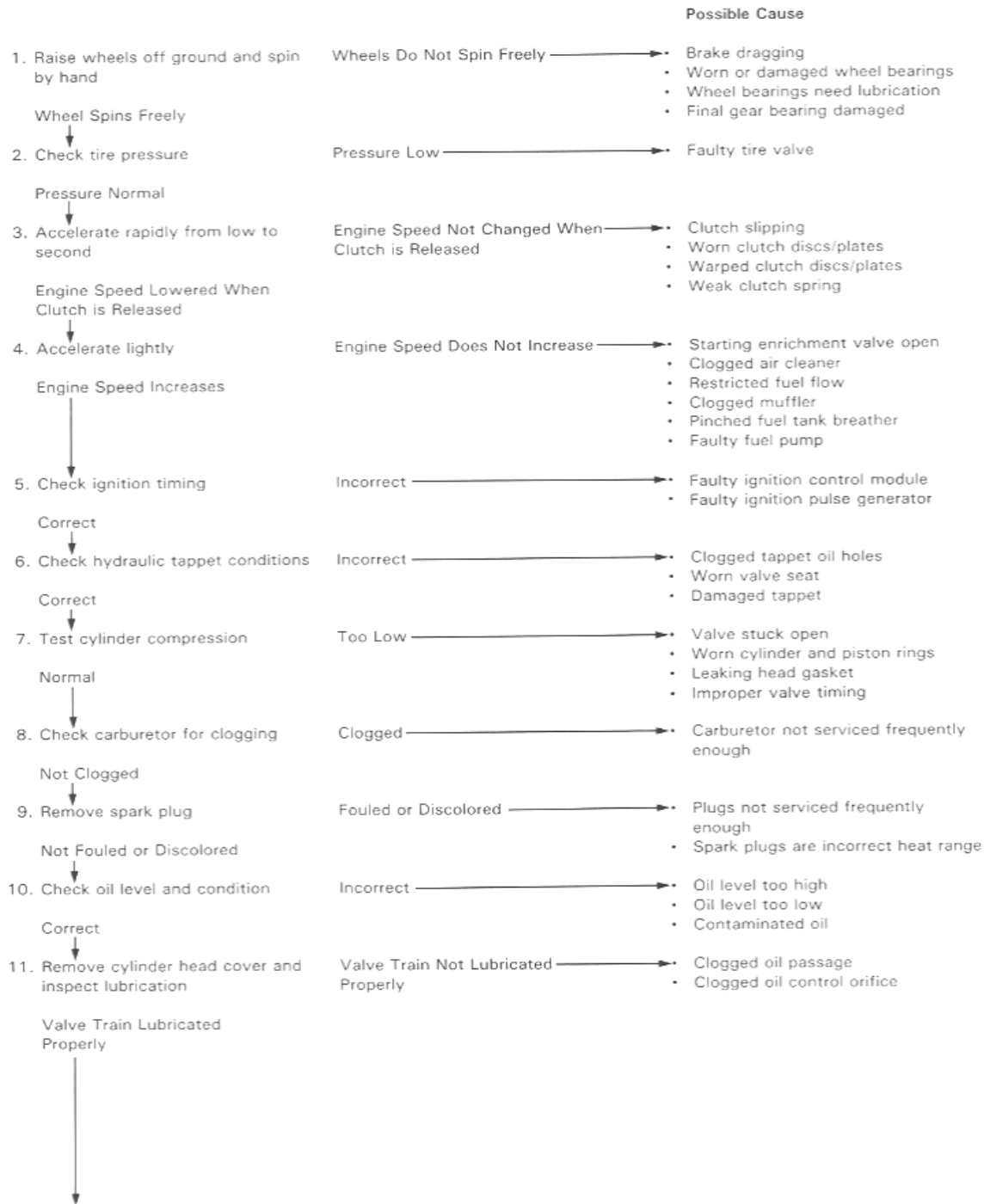

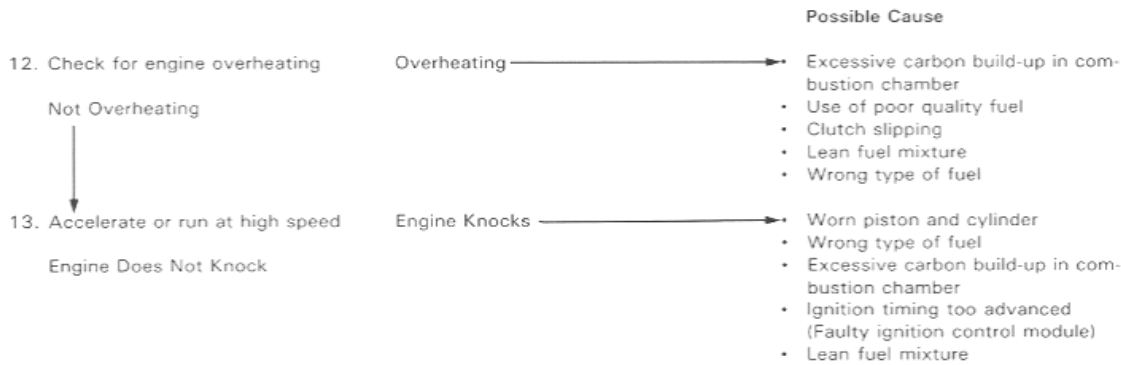

### Poor Performance at Low and Idle Speeds

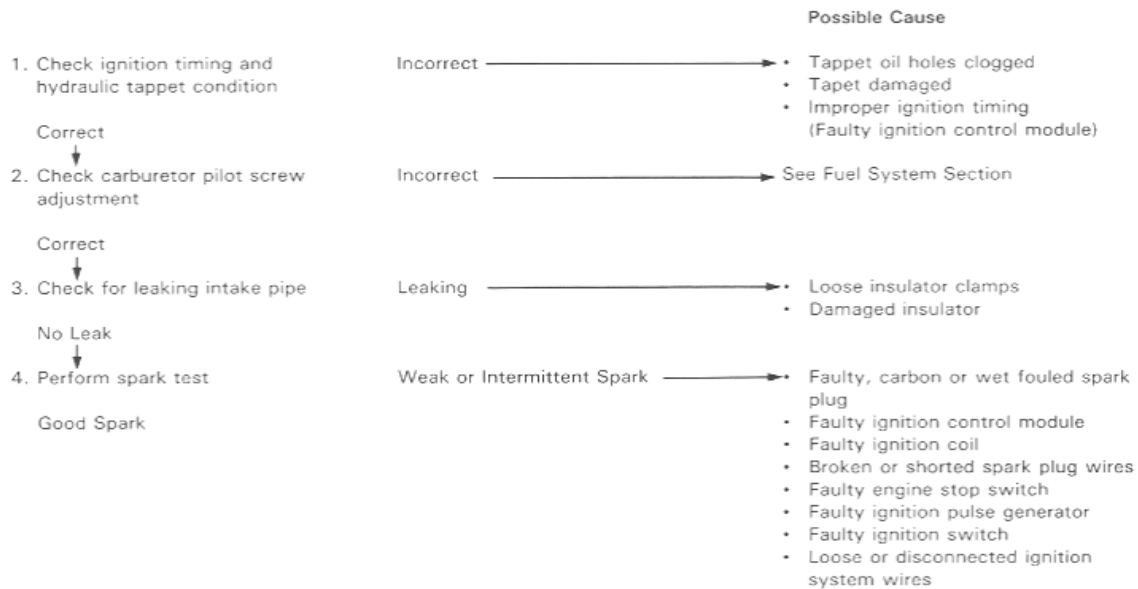

### Poor Performance at High Speed

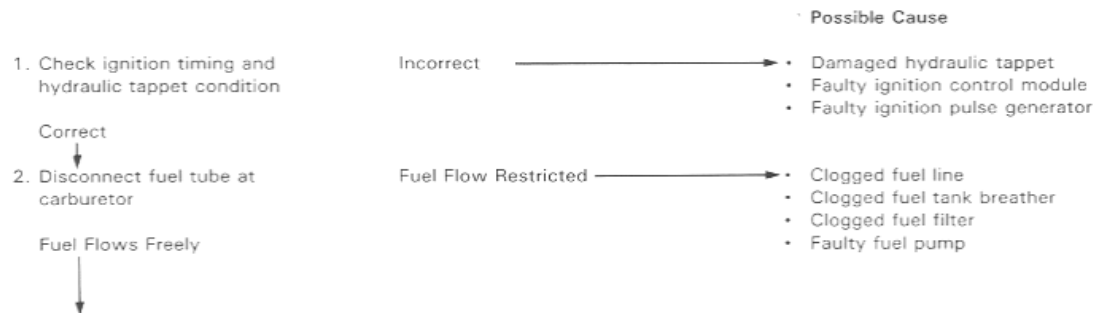

## Troubleshooting

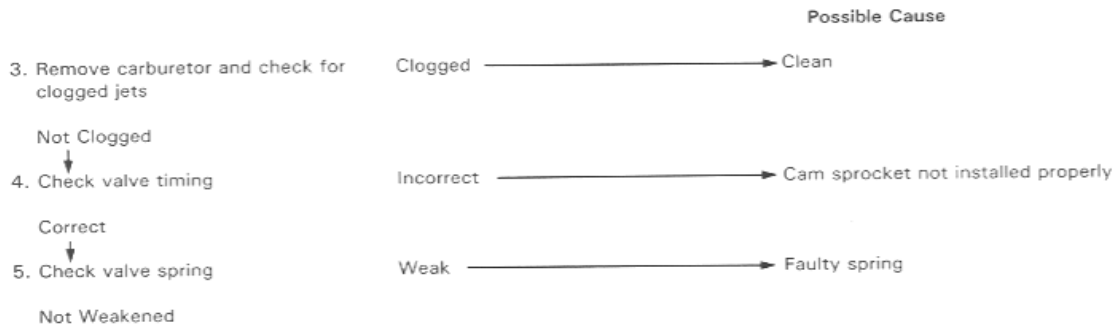

## Poor Handling → Check tire pressure

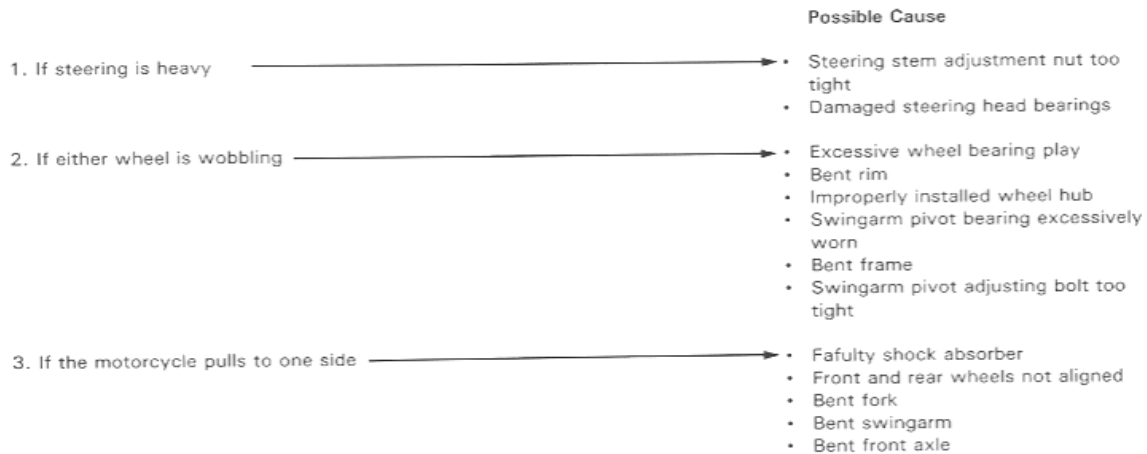

## Hydraulic Tappet

### Noisy Tappet

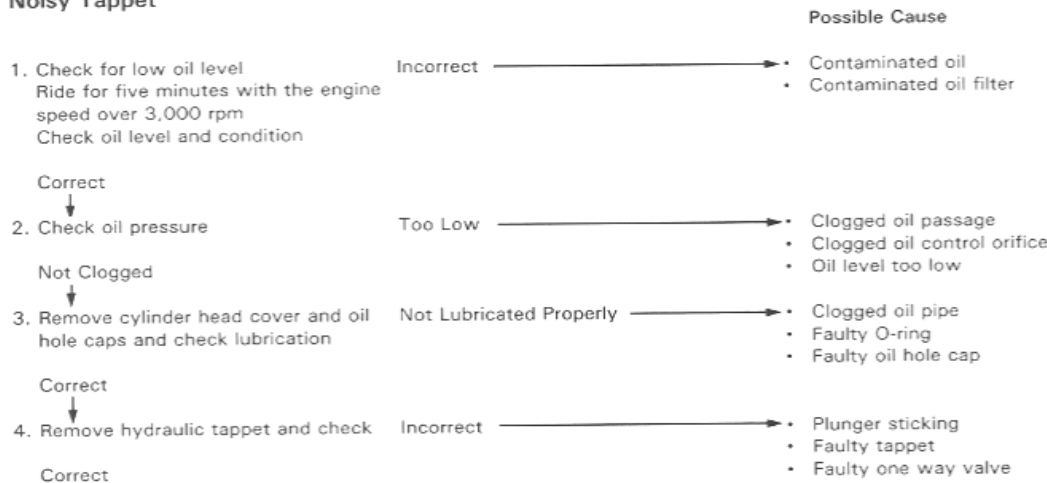

**Engine Lacks Power**

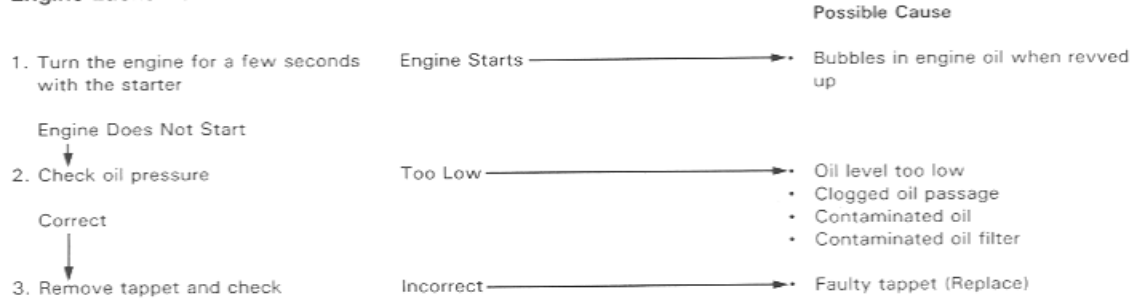

## 22. Index

Air Cleaner .....	3-5	Removal/Installation .....	12-6
Housing Removal/Installation .....	5-3	Fuel Cut-off Relay .....	18-24
Alternator .....	15-7	Level Sensor Removal/Installation .....	18-25
Removal/Installation .....	15-8	Pump and Fuel Filter Removal/ Installation .....	18-22
Anti-dive Case Disassembly/Assembly .....	12-16	System .....	5-1
Battery .....	15-4	Fuel Tank Installation .....	2-32
Body Panels .....	2-2	Removal .....	2-30
Brake System .....	14-1	Fuel Pump .....	18-24
Brake and Taillight .....	18-10	Fully Sealed Engine Cover System .....	20-1
Cable & Harness Routing .....	1-22	Gearshift Linkage Removal/Installation .....	9-10
Carburetor Choke .....	3-5	General Information .....	1-1
Carburetor Disassembly/Assembly .....	5-8	Safety .....	1-1
Draining .....	5-12	Handlebar Disassembly/Assembly .....	12-2
Idle Speed .....	3-7	Removal/Installation .....	12-4
Removal/Installation .....	5-4	Headlight .....	18-8
Separation/Combination .....	5-7	Aim .....	3-8
Synchronization .....	3-6	High Altitude Adjustment (U.S.A. Only) .....	5-11
Vacuum Tube Routing .....	5-6	Ignition System .....	16-1
Charging System/Alternator .....	15-1	Coil .....	16-6
Charging System Inspection .....	15-4	Pulse Generator .....	16-6
Clutch/Gearshift Linkage .....	9-1	Pulse Generator Removal/Installation .....	16-8
Master Cylinder Removal/Disassembly .....	9-2	Switch Removal/Installation .....	18-19
Slave Cylinder Removal/Installation .....	9-4	System Inspection .....	16-5
Clutch, Primary Drive Gear Removal/Installation .....	9-6	Timing .....	16-7
Combination Meter Disassembly/Assembly .....	18-14	Instruments .....	18-16
Removal/Installation .....	18-12	License Light .....	18-11
Connecting Rod Removal/Installation .....	10-5	Lights/Meters/Switches .....	18-1
Coolant Draining .....	6-2	Lubrication System .....	4-1
Cooling System .....	6-1	Lubrication & Seal Points .....	1-20
Crankcase Separation/Assembly .....	10-2	System Diagram .....	4-2
Crankshaft/Transmission .....	10-1	Maintenance .....	3-1
Cylinder Head/Cylinder/Piston .....	8-1	Schedule .....	3-4
Cylinder Head Cover Disassembly/Assembly .....	8-6	Model Identification .....	1-3
Removal/Installation .....	8-2	Oil Pump Disassembly/Assembly .....	4-4
Cylinder Head Disassembly/Assembly .....	8-14	Removal/Installation .....	4-3
Removal/Installation .....	8-8	Output Gear Case Removal/Installation .....	10-14
Cylinder, Piston Removal/Installation .....	8-16	Disassembly/Assembly .....	10-18
Electric Starter/Starter Clutch .....	17-1	Pilot Screw Adjustment (U.S.A. Only) .....	5-10
Emission Control Information Labels (U.S.A. Only) .....	1-30	Radiator Coolant .....	3-7
Systems .....	1-28	Disassembly/Assembly .....	6-5
Engine Removal/Installation .....	7-1	Removal/Installation .....	6-4
Heat Cover Removal/Installation .....	7-2	Reserve Tank Removal/Installation .....	6-6
Installation .....	7-8	Rear Wheel/Suspension .....	13-1
Removal .....	7-6	Rear Brake Disassembly/Assembly .....	14-8
Exhaust System Removal/Installation .....	2-27	Pedal and Linkage Removal/Installation .....	14-9
Fan Motor Switch .....	18-26	Rear Turn Signal .....	18-9
Final Drive .....	11-1	Rear Wheel Disassembly/Assembly .....	13-4
Assembly .....	11-6	Removal/Installation .....	13-2
Disassembly .....	11-4	Regulator/Rectifier .....	15-5
Removal/Installation .....	11-2	Right Crankcase Cover Removal/Installation .....	9-5
Fork Assembly .....	12-14	Self-cancelling Turn Signal System Diagram (‘89 – ‘90, ‘94 – ‘96) .....	18-3
Disassembly .....	12-12	Turn Signal System (‘89 – ‘90, ‘94 – ‘96) .....	18-17
Removal/Installation .....	12-10	Service Access Guide .....	3-2
Frame/Body Panels/Exhaust System .....	2-1	Service Information .....	14-1
Front Wheel/Suspension/Steering .....	12-1	Brake System .....	14-1
Front Brake Caliper Removal/Disassembly .....	14-6	Charging System/Alternator .....	15-1
Pad Replacement .....	14-2	Clutch/Gearshift Linkage .....	9-1
Front Master Cylinder Disassembly/Assembly .....	14-4	Cooling System .....	6-1
Front Turn Signal .....	18-8	Crankshaft/Transmission .....	10-1
Front Wheel Disassembly/Assembly .....	12-8	Cylinder Head/Cylinder/Piston .....	8-1

## Index

---

Electric Starter/Starter Clutch .....	17-1
Engine Removal/Installation .....	7-1
Final Drive .....	11-1
Frame/Body Panels/Exhaust System .....	2-1
Front Wheel/Suspension/Steering .....	12-1
Fuel System .....	5-1
Ignition System .....	16-1
Lights/Meters/Switches .....	18-1
Lubrication System .....	4-1
Maintenance .....	3-1
Rear Wheel/Suspension .....	13-1
Shock Absorber Disassembly/Assembly .....	13-7
Removal/Installation .....	13-6
Side Stand .....	3-8
Side Stand Switch Inspection .....	18-21
Removal/Installation .....	18-20
Spark Plug .....	3-5
Specifications .....	1-4
Starter Clutch Removal/Installation .....	17-8
Starter Motor Disassembly/Assembly .....	17-6
Removal/Installation .....	17-4
Starter Relay Switch .....	17-7
Steering Stem Installation .....	12-22
Removal .....	12-20
Sub-frame Removal/Installation .....	7-4
Swingarm Disassembly/Assembly .....	13-10
Removal/Installation .....	13-8
System Location .....	15-2, 16-2, 17-3, 18-2
Technical Feature .....	20-1
Temperature Gauge .....	18-27
Thermo Sensor .....	18-26
Thermostat Removal/Installation .....	6-7
Tools .....	1-18
Torque Values .....	1-14
Transmission Disassembly/Assembly .....	10-12
Removal/Installation .....	10-10
Troubleshooting	
Brake System .....	14-1
Clutch/Gearshift Linkage .....	9-1
Cooling System .....	6-1
Crankshaft/Transmission .....	10-1
Cylinder Head/Cylinder/Piston .....	8-1
Electric Starter/Starter Clutch .....	17-1
Final Drive .....	11-1
Frame/Body Panels/Exhaust System .....	2-1
Front Wheel/Suspension/Steering .....	12-1
Fuel System .....	5-2
Lights/Meters/Switches .....	18-4
Lubrication System .....	4-1
Rear Wheel/Suspension .....	13-1
Turn Signal Cancel Control Unit (Angle Sensor)	
Removal/Installation ('89 - '90, '94 - '96) .....	12-18
Water Pump Removal/Installation .....	6-3
Wiring Diagram .....	19-1

## Symbols

The symbols used throughout this manual show specific service procedures. If supplementary information is relating to these symbols, it would be explained specifically in the text without the use of the symbols.

	Replace the part(s) with new one(s) before assembly.
	Use special tool
	Use optional tool. These tools are obtained as you order parts.
 10 (1.0, 7.2)	Torque specification. 10 N·m (1.0 kg-m, 7.2 ft-lb)
	Use recommended engine oil, unless otherwise specified.
	Use molybdenum oil solution (mixture of the engine oil and molybdenum grease with the
	Use multi-purpose grease (Lithium based multi-purpose grease NLGI #2 or equivalent)
	Use molybdenum disulfide grease (containing more than 3% molybdenum disulfide, NLGI equivalent) Example: Molykote® BR-2 plus manufactured by Dow Corning, U.S.A. Multi-purpose M-2 manufactured by Mitsubishi Oil Japan
	Use molybdenum disulfide paste (containing more than 40% molybdenum disulfide, NLGI equivalent) Example: Molykote® G-n Paste manufactured by Dow Corning, U.S.A. Honda Moly 45 (U.S.A. only) Rocol ASP manufactured by Rocol Limited, U.K. Rocol Paste manufactured by Sumico Lubricant, Japan
	Use silicone grease
	Apply a locking agent. Use the agent of the middle strength, unless otherwise specified.
	Apply sealant
	Use brake fluid, DOT 3 or DOT 4. Use the recommended brake fluid, unless otherwise sp
	Use Fork or Suspension Fluid.





---

---